



الفيزياء الطبية
قسم تقنيات البصريات
المرحلة الأولى
د. محمد عجمي عبد

تقنيات البصريات

1-Human eye

The best thing that the eye can be likened to is a camera that forms a real, inverted imagination on the retina. The brain subsequently undertakes the task of analyzing and correcting this imagination, and thus seeing things and bodies as they are in reality. The human eye is characterized by being approximately spherical in shape (Figure 1) with a radius of $r \approx 1.2cm$. In front of it is a transparent layer called the cornea, which is birefringent $n = 1.351$ and filled with a fluid with a watery consistency that is birefringent $n = 1.333$.

إن أفضل ما يمكن تشبيهه العين به هو كاميرا Camera تقوم بتشكيل خيال حقيقي مقلوب على الشبكية، يتولى الدماغ لاحقاً مهمة تحليل هذا الخيال وتصحيحه وبالتالي رؤية الأشياء والأجسام كما هي في الواقع. تمتاز العين البشرية بأنها كروية الشكل تقريباً وب نصف قطر $r \approx 1.2cm$ في مقدمتها طبقة شفافة تدعى بالقرنية Cornea قرين انكسارها $n = 1.351$ مملوءة بسائل ذو قوام مائي قرين انكسار $n = 1.333$

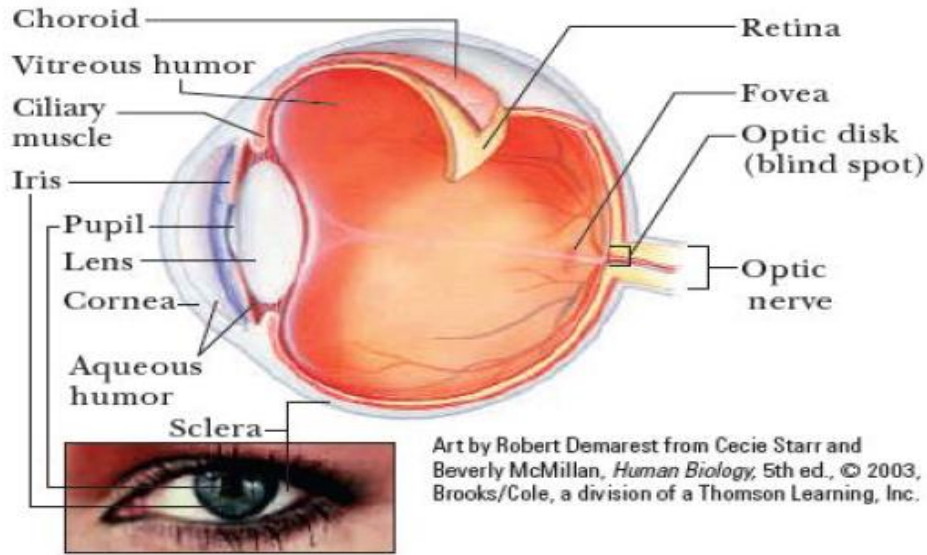

تقنيات البصريات

خلف القرنية تتواجد القرنية Iris التي تتحكم بنصف قطر بؤبؤ العين Pupil، يقع هذا البؤبؤ $n = 1.437$ ذات معامل الانكسار الكبير نسبياً Focal lens أمام ما يعرف بالعدسة العينية يحيط بالعدسة سائل شفاف يدعى بالمائع الزجاجي Vitreous humor وله نفس معامل انكسار الماء $n = 1.333$.

تعتبر القرنية المسؤولة عن انكسار الضوء الساقط على العين ومن ثم تقوم بتوجيهه باتجاه العدسة العينية التي تقوم بدورها بتركيز هذا الضوء ليسقط في المحرق الواقع خلف العدسة العينية. تقع الأخيلة المتشكل للأجسام في منطقة حساسة من الشبكية Retina (تدعى باللطخة الصفراء) Macular الموجودة فيما يعرف بالحفرة المركزية. تتركز في هذه المنطقة نسبة عالية جداً من المخاريط Cones والعصيات Rods الضوئية المسؤولة عن رؤية الألوان بفعل حساسيتها العالية لمختلف الأطوال الموجية للضوء الوارد كما في الشكل 2:

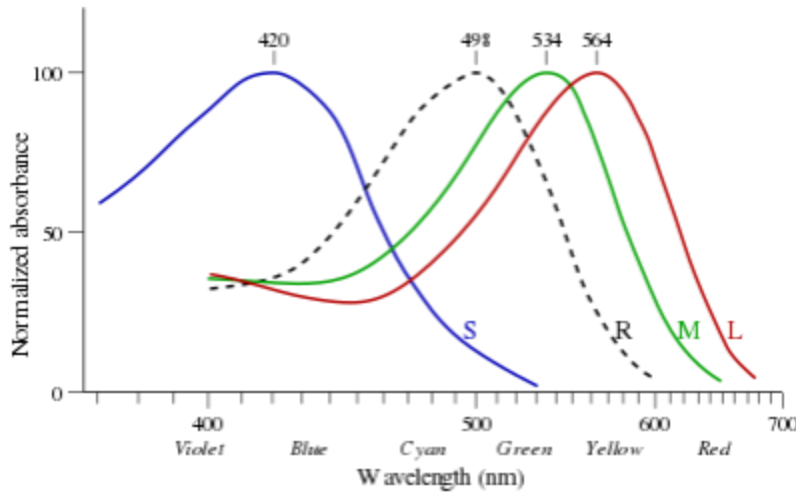

The cornea is responsible for the refraction of the light falling in the eye and then directing it towards the focal lens, which in turn concentrates this light to fall in the focus behind the lens. The formed images of the objects are located in a sensitive area of the retina called macular. In this region concentrates a Very high percentage

تقنيات البصريات

of cones and rods, which are responsible for distinguishing colors due to its sensitivity to the different wavelengths of the incident light.

Table1:Optical parameters of typical human eye. R indicates surface radius, t is the distance to next surface, n is the index of refraction between surfaces

Surface Radius	Distance	Refractive Index
R ₁ (air to cornea) 7.8 mm	t ₁ (cornea) 0.6mm	1.376
R ₂ (cornea to aqueous) 6.4 mm	t ₂ (aqueous) 3.0mm	1.336
R ₃ (aqueous to lens) 10.1 mm	t ₃ (lens) 4.0mm	1.386–1.406
R ₄ (lens to vitreous) 6.1 mm	t ₄ (vitreous) 16.9mm	1.337

2-Introduction:

In order to understand how the vision process works, than to develop and design precise optical systems and instruments, the optical modelling of the human eye and the accurate prediction of the optical performance is a crucial topic for the light engineering as well as vision science. In the past, various optical eye models with different features were developed, among them the Gullstrand’s schematic eye model won the Nobel prize in 1911 .He illustrated relevant optical surfaces (the cornea and the crystalline lens) of an eye and described their geometry quantitatively. After 100 years, today, the development of optical simulation software and ray tracing methods enable us to reproduce the optical system of the human eye quantitatively with more accuracy. For instance, to construct a statistical eye model, at first the biometrical data of the human eye was assessed using clinical

devices, than new simulated data were generated and finally validated with biometric data . However, previous eye models focused particularly only in some features like only corneal data, only accommodation or aging, used personalised or average population data and either mono- and polychromatic light. To the best of our knowledge, there is no eye model of the complete optical system. Therefore, developing a complete eye model may prove advantageous to understand the vision process and its application in the ophthalmology, the medical technology and the light engineering. This paper presents a review of optical eye models and provide insight into which facts will play an important role to develop a complete eye model by using contemporary technology

2-1 Optical eye models

1-The human eye

2-Gullstrand eye model

3-Emsley reduced eye

4-Navarro eye model

Gullstrand eye model:

The figure represents a well-known eye model with optical components and values proposed by an ophthalmologist Allvar Gullstrand, who won the Nobel Prize in physiology and medicine in 1911 for his work concerning the dioptrics of the eye. Prior to his eye model, no optical eye model have included as many optical refracting surfaces as he described with his model. The idea behind the eye model

تقنيات البصريات

is that for him as an ophthalmologist, if more optical surface parameters, e.g. radius of curvature and refractive index, are described, it helps to predict the eye diseases effect in which optical component either on the cornea or lens or on other components is and how much optical parameter value deviates from the healthy and disease eye. This knowledge leads to evaluate about the disease severity, progression and diagnosis outcomes after the treatment.

يعرض الشكل 2 نموذج للعين الذي يحتوي على مكونات وقيم بصرية اقترحه طبيب العيون ألفار جولستراند، الذي فاز بجائزة نوبل في علم وظائف الأعضاء والطب عام 1911 عن عمله المتعلق بمنظار العين. لم يتضمن أي نموذج عين بصري قبل نموذج جولستراند العديد من الأسطح المنكسرة البصرية كما وصفها في نمودجه. الفكرة وراء ذلك النموذج هي أنه بالنسبة له كطبيب عيون، إذا كانت هناك المزيد من المعلومات السطحية البصرية، حيث تم وصف نصف قطر الانحناء ومعامل الانكسار، وهو يساعد على التنبؤ بتأثير أمراض العيون التي يكون فيها المكون البصري سواء على القرنية أو العدسة أو على المكونات الأخرى ومدى انحراف قيمة المعلومات البصرية عن العين السليمة والمريضة. وتؤدي هذه المعرفة إلى تقييم مدى خطورة المرض وتطوره وتشخيصه النتائج بعد العلاج.

He had measured the optical surface parameters of the human eye by using techniques and devices (slit lamp, ophthalmoscope) available at that time and collected and averaged data for each optical component of healthy eyes. Those values were considered as gold standard values for the healthy eye. He assumed following six-refracting surfaces which are essential to model a human eye: air to anterior cornea, aqueous humor and posterior cornea, aqueous humor to lens outer surface(cortex), lens core to lens cortex and vitreous humor and lens cortex. His eye model's corneal total refractive power around 43 D, which was two-third of the eye's focusing power (58 D) and average lens power was approximately 19 D .

تقنيات البصريات

لقد قام بقياس معاملات السطح البصري للعين البشرية باستخدام التقنيات والأجهزة (المصباح الشقي، منظار العين) المتاحة في ذلك الوقت وقام بجمع البيانات ومتوسطها لكل مكون بصري للعين السليمة. واعتبرت هذه القيم بمثابة القيم القياسية الذهبية للعين السليمة. لقد افترض اتباع الأسطح الستة المنكسرة والتي تعتبر ضرورية لنموذج العين البشرية: الهواء إلى القرنية الأمامية، السائل المائي والقرنية الخلفية، السائل المائي إلى السطح الخارجي للعدسة (القشرة)، ونواة العدسة إلى قشرة العدسة، السائل الزجاجي وقشرة العدسة. تبلغ قوة انكسار القرنية الإجمالية لنموذج عينه حوالي D43 ، والتي تمثل ثلثي قوة تركيز العين (58 D) وكان متوسط قوة العدسة حوالي D.19

He considered refractive index values, distance next to next surface, radius of curvature and shape as parameters. In addition, he introduced the term astigmatism in eye optics. Furthermore, he described for the first time the mechanism of intra capsular accommodation, which was not considered before his eye model. This mechanism means that the human lens is made up of different fiber layers on the lens cortex and nucleus , thus the refractive index differs, resulting the focusing of the object varies in lens cortex and nucleus. This knowledge helped in the future to understand and invent Intra ocular lens with different focal power for cataract.

لقد اعتبر قيم معامل الانكسار والمسافة بجوار السطح التالي ونصف قطر الانحناء والشكل كمعاملات رئيسية. وبالإضافة إلى ذلك، فقد أدخل مصطلح الاستجماتيزم في بصريات العين. علاوة على ذلك، فقد وصف لأول مرة آلية التكيف داخل المحفظة، والتي لم تكن في الاعتبار قبل نموذج عينه. تعني هذه الآلية أن عدسة الإنسان تتكون من طبقات ليفية مختلفة على قشرة العدسة ونواتها ، وبالتالي يختلف معامل الانكسار، مما يؤدي إلى اختلاف تركيز الأشياء في قشرة العدسة ونواتها. ساعدت هذه المعرفة في المستقبل على فهم وابتكار عدسة داخل العين بقوة بؤرية مختلفة لإعتماد عدسة العين.

تقنيات البصريات

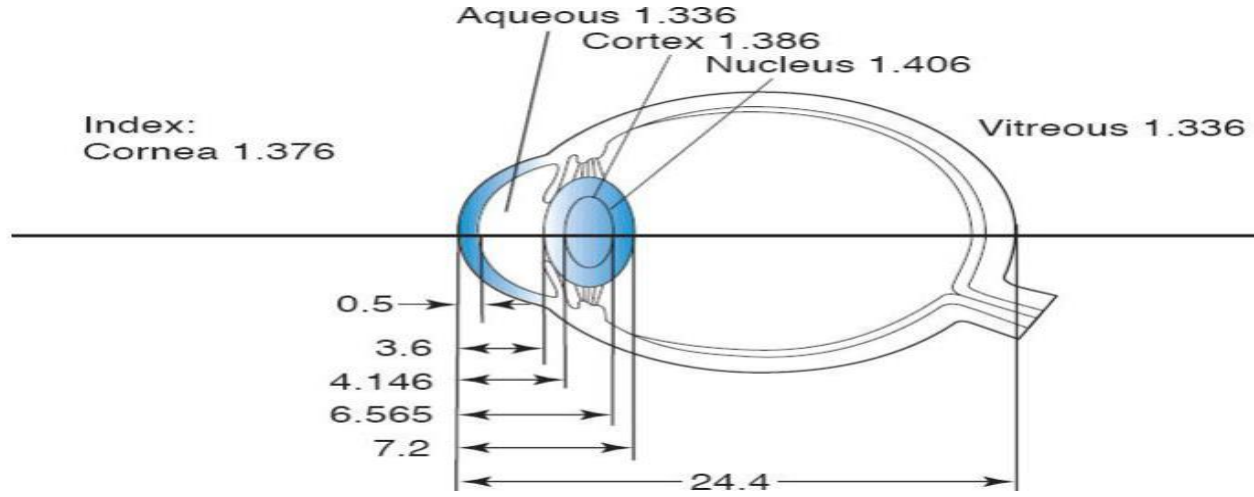

Fig. 2 Optical components of the Gullstrand's schematic eye in relaxed form; all values are in mm

His eye model does not provide information about a sphericity about the optical surfaces, the curved form of the retina, many layered lens structure (GRIN Structure) and the opening size of the pupil. The values were for healthy eyes, which does not illustrate which age or ethnic group was taken, which wavelength was sent to form an image and in which illuminance environment the values were measured.

لا يقدم هذا النموذج معلومات حول عدم وضوح الرؤية فيما يتعلق بالأسطح البصرية، والشكل المنحني لشبكية العين، وبنية العدسة المتعددة الطبقات (تركيب Grin) وحجم فتحة حدقة العين. كانت القيم للعيون السليمة، والتي لا توضح العمر أو المجموعة العرقية التي تم التقاطها، والطول الموجي الذي تم إرساله لتشكيل صورة وبيئة الإضاءة التي تم قياس القيم فيها.

3-Reduced paraxial schematic eyes:

Further simplifications are possible that may give models accurate enough for some calculations such as estimates of retinal image size. Reduced eyes contain only an anterior cornea as a refracting surface. In the more sophisticated eyes, the two principal points and the two nodal points are separated, but in reduced eyes, the principal points P and P' must be at the corneal vertex V , and the nodal points N and N' must be at the corneal center of curvature. For the eye power to be similar to those of more sophisticated eyes, reduced eyes must have shorter axial lengths. As the cornea has absorbed the power of the lens, its radius of curvature is much smaller than those of more sophisticated eyes. As reduced eyes lack a lens, optical parameters associated with accommodation cannot be investigated.

تقنيات البصريات

4-Listing reduced eye:

For understanding, listing simplified the data data by choosing the single principle point and single nodle point lying midway between two principle points and two nodal points respectively , this is called Listing reduced eye.

TABLE 5: Comparing Gullstrand's schematic eye and Listing's reduced eye.

Features	Gullstrand's schematic eye	Listing's reduced eye
Principal focus F_1	15.7 mm in front of the cornea	17 mm in front of the cornea
F_2	24.4 mm behind the cornea	24.4 mm behind the cornea
Principal points P_1	1.3 mm behind the cornea in anterior chamber	1.5 mm behind the cornea in anterior chamber
P_2	1.60 mm in the anterior chamber	Nil*
Nodal points N_1	7.08 mm from the cornea	7.2 mm from the cornea
N_2	7.33 mm from the cornea in the lens	7.22 mm from the cornea in the lens

*There is only one principal point in Listing's reduced eye

تقنيات البصريات

1- العيوب البصرية للعين:

عند تجاوز العين لحدود الرؤيا السليمة والواضحة، أي إذا كانت نقطة الكثب أكبر من 25 cm أو نقطة المدى أصغر من ∞ ، نكون أمام عيب بصري ينبغي تصحيحه إما جراحياً أو فيزيائياً باستخدام العدسات المناسب

1-1 Myopia قصر البصر

يكون الإنسان قادر على رؤية الأجسام القريبة بوضوح في حين أنه يعاني من صعوبة رؤية الأجسام البعيدة. يعود هذا العيب البصري إلى خلل في عمل القرنية أو العدسة العينية بحيث أن الخيال المتشكل لجسم في ∞ ، لا يقع على الشبكية وإنما أمامها.

If an eye is myopic, only close objects can be seen sharply and with good resolution. Accommodation fails to adjust for more distant objects. The reason for this effect can be an eye-ball which is too long, too short a radius of curvature of the cornea, or an eye lens with a very short focal length. Figure 3 shows these three cases of myopia. The correction of this problem can be by means of spectacles with a negative refractive power.

تقنيات البصريات

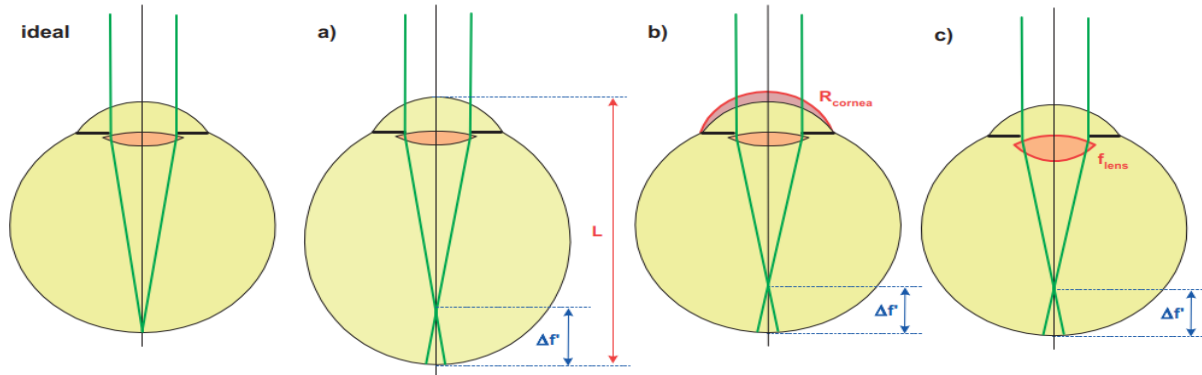

Figuer1: The three most important reasons for myopia. In case a) the eye-ball is too long, in case b) the curvature of the cornea is too large, and in case c), the refractive power of the eye lens is too large.

Since natural accommodation results in a shorter focal length of the eye lens, myopia can therefore be corrected with the help of an additional lens. Due to the sign of the effect it is not possible to compensate for myopia by accommodation. If no correction lens is used, the accommodation reduces the visus of the eye as can be seen in last figure. If the radiance is low for scotopic vision, a natural myopia of the eyes due to adaptation occurs. The reasons for this night-myopia are the immobile position under low radiance and the chromatic shift of the best accommodation.

The treatment:

This visual error is corrected with a spherical refractor, which is a concave lens that forms a virtual true (non-inverted) image, located at the actual far point of the myopic eye, so that it becomes a real image for the second surface of the lens. Thus,

تقنيات البصريات

light rays that comes from it refracts through the correction lens, forming an inverted image on the retina, which means a clear vision, figuer3.

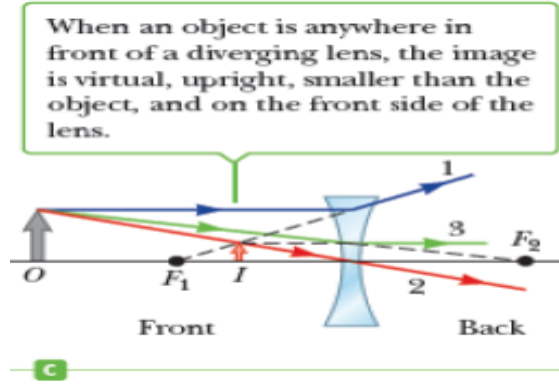

شكل 2: تشكل العدسة المبعدة diverging lens للجسم O خيال وهمي I وصحيح وأصغر من الجسم الأصلي

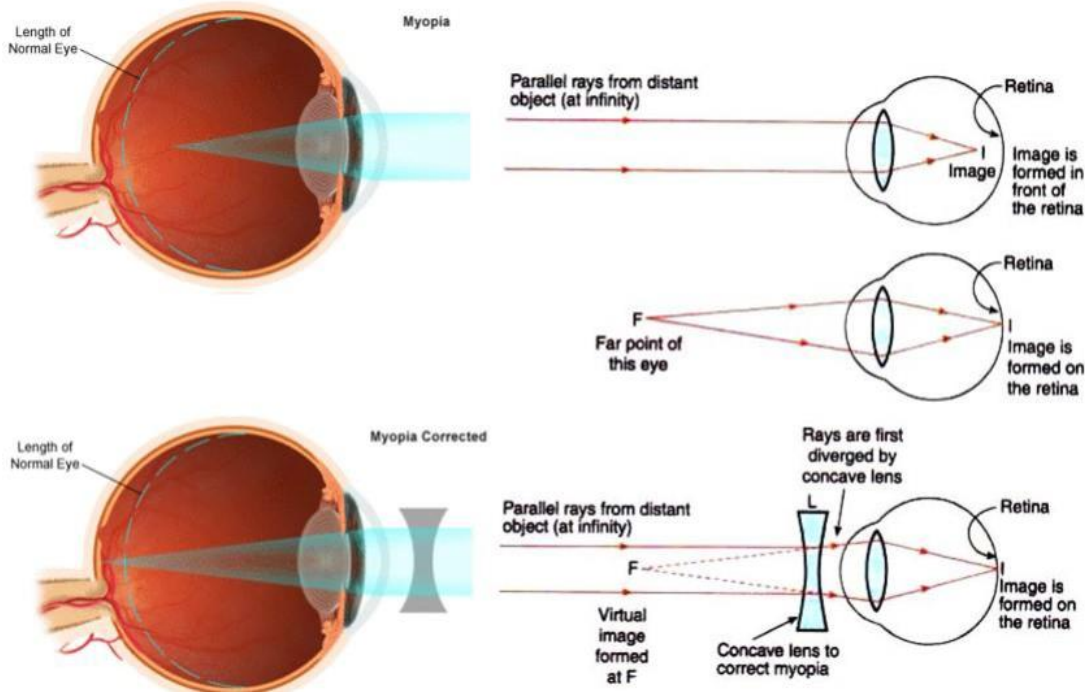

شكل 3: آلية معالجة العين Myopic eye باستخدام عدسة مبعدة.

تقنيات البصريات

2-2Hyperopia: بعد البصر

بصورة معاكسة لحالة قصر النظر، يعاني المريض في حالة مد النظر من مشكلة عدم القدرة على رؤية الأجسام القريبة بوضوح، في حين أنه يكون قادر على رؤية الأجسام البعيدة بوضوح. يعزى ذلك أيضاً إلى مشكلة في القرنية والعدسة العينية، إذ أن القوة الكاسرة للعدسة تكون منخفضة وبالتالي لا تستطيع كسر الأشعة الضوئية، القادمة من الأجسام القريبة، بشدة كافية لكي يتشكل خيال على الشبكية وإنما يتشكل الخيال خلف الشبكية (البعد البؤري يكون كبير جداً) ، مما يعني عدم وضوح في رؤية هذه الأجسام القريبة .
الشكل 4.

On the contrary to Myopia, a hyperopic patient suffers from the problem of being unable to see close objects clearly, while being able to see distant objects clearly. This is also due to an error in the cornea and the ocular lens, since the refractive force is low and therefore cannot refract the light rays, coming from nearby objects, strongly enough to form an image on the retina (the focal length is very big). Means the blurring of seeing these close objects.

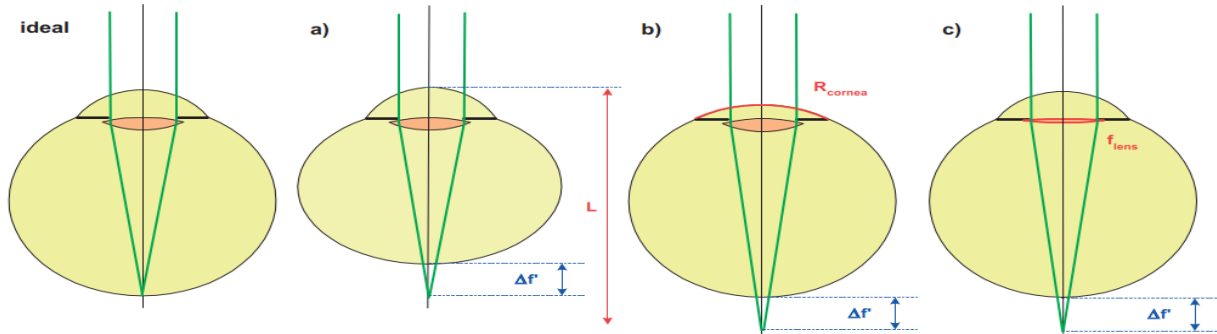

Figuer4:The three most important reasons for hyperopia.In case a) the eye-ball is too short, in case b) the curvature of the cornea is too small, and in case c) the refractive power ofthe eye lens is too small. The first diagram shows an ideal eye.

تقنيات البصريات

The treatment:

This optical error can be treated (corrected) with a convex lens in order to increase the eye's refractive force, this lens creates a virtual image of the nearby body, so that this image falls at the patient's near point, Therefore the lens treats it as a real object, refracts the light rays coming from it strongly to form an image exactly on the retina, which means seeing these nearby objects clearly.

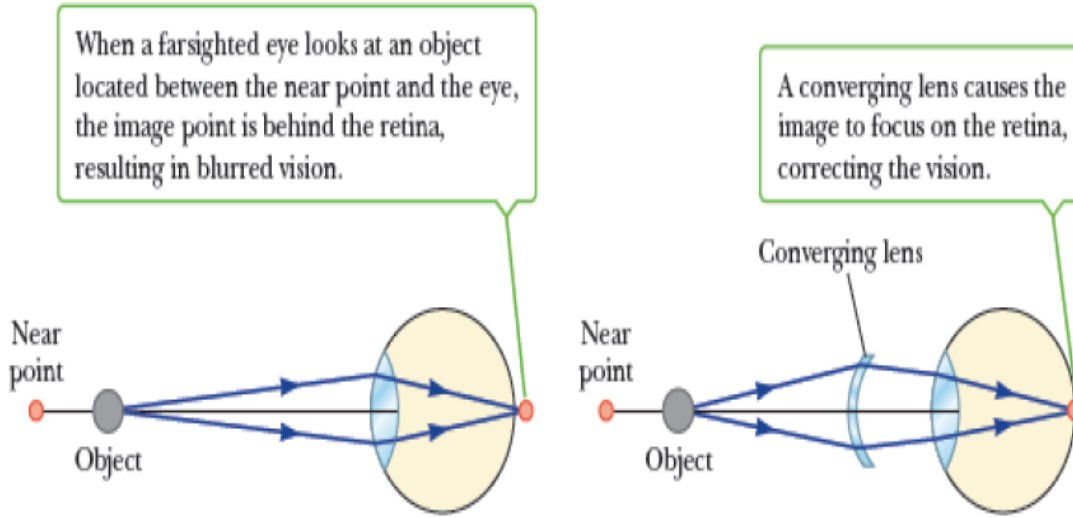

الشكل 5 : معالجة بعد البصر باستخدام عدسة مجمعة

3-2 Astigmatism

If the refractive power of the eye is different in the horizontal and the vertical cross-section, this is known as astigmatism. In most cases this defect results from different radii of the cornea. Usually the refractive power is larger in the vertical section. The correction of this aberration is only possible with a toric lens. For the description of this refractive error, the amount of astigmatic difference and the location of the azimuth are necessary. It is also possible to correct the astigmatism of the cornea by using hard contact glasses which force the cornea to adjust the radii of curvature. Only a small residual error due to a tear film usually remains.

The treatment

astigmatism, is not a spherical refractive error and cannot be fully corrected with a spherical lens, but it can be corrected with what is referred to as a cylindrical lens. A cylindrical lens has maximum dioptric power in one meridian, while the orthogonal (perpendicular) meridian has no dioptric power.

تقنيات البصريات

Introduction:

as far as astronomy is concerned is just a “light bucket”. In almost all applications, we are not interested in magnification, but simply in collecting enough photons to measure. Usually, this means collecting enough photons to achieve a desired “signal/noise” ratio, always important in astronomy. With larger telescopes, we increase the collecting area, so we increase the number of photons collected. This means that we can observe fainter objects, but we can also improve resolution. This can be spatial resolution, but it is often more important to get better spectral resolution (eg. by using echelle spectrographs) or better time resolution for “high-speed” photometry or spectroscopy. This means that one can take very short exposure (direct or spectroscopic) measures whilst retaining good signal/noise.

بقدر ما يتعلق الأمر بعلم الفلك. في جميع التطبيقات تقريباً، لا نهتم بالتكبير، ولكن نهتم بجمع ما يكفي من الفوتونات لقياسها. هذا يعني جمع ما يكفي من الفوتونات لتحقيق نسبة "الإشارة/الضوضاء" والتي تعتبر مهمة دائماً في علم الفلك. وباستخدام التلسكوبات الأكبر حجماً فإننا نزيد مساحة جمع الفوتونات، لذلك نقوم بزيادة عدد الفوتونات المجمعة. وهذا يعني أنه يمكننا مراقبة الأجسام الدقيقة، وتحسين الدقة. يمكن أن يكون هذا دقة مكانية، ولكن غالباً ما يكون الحصول على دقة طيفية أفضل (على سبيل المثال باستخدام أجهزة قياس الطيف الضوئي) أو دقة زمنية أفضل — "عالية السرعة" أمراً أكثر أهمية وهو القياس الضوئي أو التحليل الطيفي. وهذا يعني أنه يمكن للمرء اتخاذ تدابير تعريض قصيرة جداً (مباشرة أو طيفية) مع الاحتفاظ بالإشارة/الضوضاء الجيدة.

تقنيات البصريات

Fundamental principles

Most large reflecting telescopes are composed of conic surfaces (paraboloids, ellipsoids, hyperboloids) formed by rotating conic sections about their axes of symmetry. Working directly with reflection laws for conics is thus more informative than dealing with lens formulas. In the realm of optics, the fundamental property of conics is that the normal at a given point on any conic bisects the angle formed by the two radii joining that point to the two foci (figuer). This means that all optical rays issuing from a source located at one of the foci will converge at the other focus and thus form a perfect image of the source. This perfect imaging of a point source is called "stigmatism." The simplest case is that of the parabola, which is a degenerated ellipse with one of its foci at infinity. Rays issuing from this focus at infinity, that is to say, rays parallel to the parabola axis, will, after reflection, converge at the parabola focus.

تتكون اغلب التلسكوبات العاكسة الكبيرة من أسطح مخروطية (أشكال مكافئة، إهليلجية، أسطح زائدية) تتكون من مقاطع مخروطية دوارة حول محور التناظر. وبالتالي فإن العمل بشكل مباشر مع قوانين الانعكاس للمخروطات يعد أكثر إفادة من التعامل مع صيغ العدسات. في عالم البصريات، الخاصية الأساسية للمخروطات هي أن العمودي عند نقطة معينة على أي مخروطي ينصف الزاوية التي يشكلها نصف القطر الذي يربط تلك النقطة بالبؤرتين (الشكل التالي في الأسفل). وهذا يعني أن جميع الأشعة الضوئية الصادرة من مصدر يقع في إحدى البؤرتين سوف تتقارب في البؤرة الأخرى وبالتالي تشكل صورة مثالية للمصدر. يُطلق على هذا التصوير المثالي لمصدر نقطي اسم «اللابؤرية». وأبسط حالة هي حالة القطع المكافئ، وهو شكل بيضاوي متدهور تقع إحدى بؤرتيه في اللانهاية. والأشعة الصادرة من هذه البؤرة عند اللانهاية، أي الأشعة الموازية لمحور القطع المكافئ، سوف تتقارب بعد الانعكاس عند بؤرة القطع المكافئ.

تقنيات البصريات

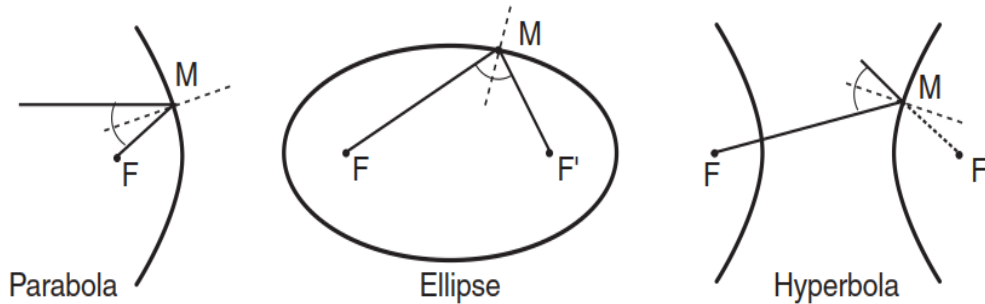

Fig. The property of conics that is the foundation of reflecting telescopes:the normal at any point of a conic bisects the two radii issuing from that point (Apollonius theorem).

The next case uses a second conic surface with one of its foci coincident with the focus of the parabola. This second conic surface will reimage the original source at its second focus, again in a perfectly stigmatic way. When this second conic is an ellipsoid, the system is called a“Gregorian,” and when it is a hyperboloid, it is a “Cassegrain” (Fig. 4.2). A system with three powered mirrors follows the same principle.

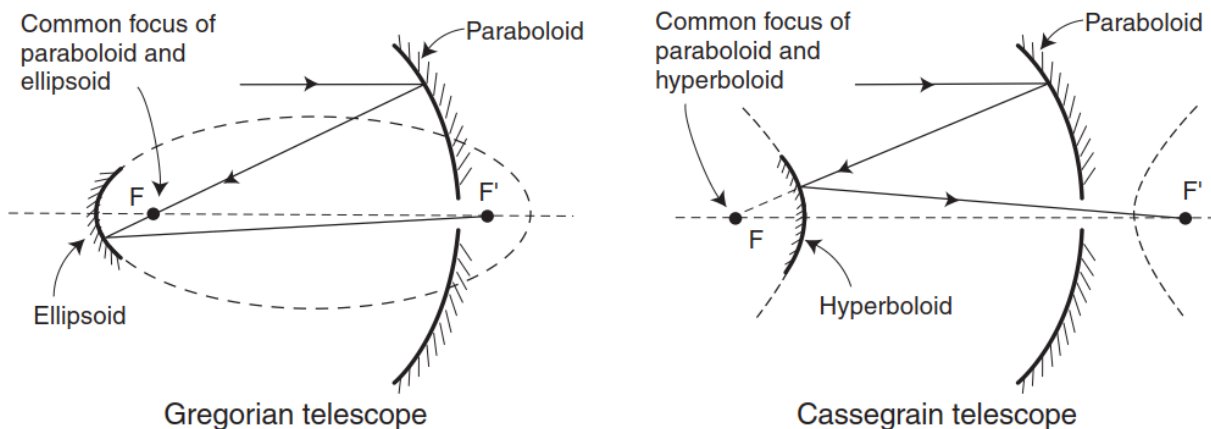

Fig. 4.2. A system of coaxial conic surfaces with coincident foci is “stigmatic.”

An optical telescope:

is an instrument that gathers and focuses light, mainly from the visible/IR part of the electromagnetic spectrum, to create a magnified image for direct view, or to make a photograph, or to collect data through electronic image sensors.

Telescope Functions**1-Light-gathering power:**

The Light-gathering power of a telescope is simply its ability to collect light and is therefore proportional to the collecting surface area, or a^2 , if a is the aperture (usually by “aperture” we mean the diameter of the primary mirror).

For point sources (such as stars), ideally the image is concentrated into the same area irrespective of focal length (or f-ratio) so “speed” depends only on aperture.

2- Resolving power

Light passing through a circular aperture suffers Fresnel diffraction, so that even an infinitely small point source will show a somewhat diffuse image with an interference pattern – the diffraction pattern

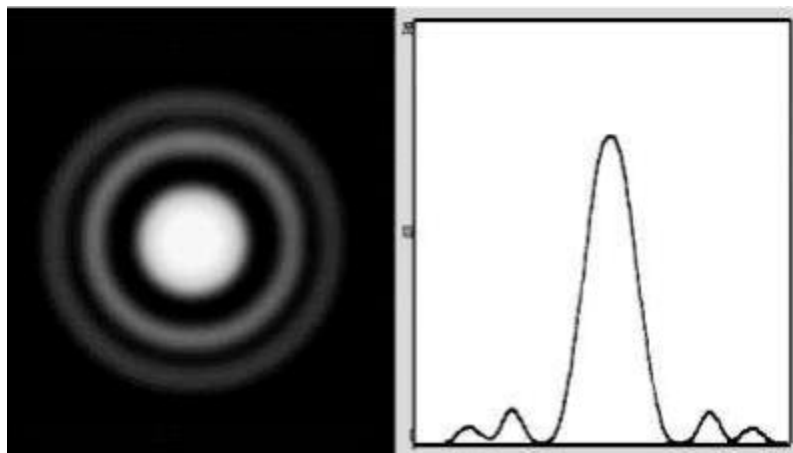

Figure 14: Diffraction pattern produced by a circular aperture. The central spot is the Airy disk.

تقنيات البصريات

In astronomy, the radius of the first minimum in the diffraction pattern is referred to as the Airy disk. The angular radius is given by:

$$\theta = 1.22 \frac{\lambda}{a}$$

Actually $\sin \theta$, but we can write $\sin \theta = \theta$ because the angles are very small. And the linear radius is:

$$\theta = 1.22 f \frac{\lambda}{a}$$

where:

f = focal length

a = aperture (diameter of the objective)

λ = wavelength

Example: For white light ($\lambda \sim 5600\text{\AA} = 5.6 \times 10^{-5}\text{cm}$, given a lens of diameter 4cm and a focal length of 30cm, the Airy disc has an angular radius:

$$1.22 \times \frac{5.6 \times 10^{-5}}{4} = 1.71 \times 10^{-5} \text{ radians} = 3.5 \text{ arcsec}$$

and a linear size of:

$$30 \times 1.71 \times 10^{-5} = 5.1 \times 10^{-4} \text{ cm.}$$

For a point source (star), the central disk is thus $\sim 0.01\text{mm}$ in diameter.

تقنيات البصريات

Types of telescopes:

Refracting and Reflecting Telescopes

• A lens or mirror changes the direction of light to concentrate incoming light at a focus and form an image of the light source at the focal plane.

• Telescopes using lens are refractors, and those using mirrors are reflectors.

- تقوم العدسة أو المرآة بتغيير اتجاه الضوء لتركيز الضوء الوارد عند التركيز وتكوين صورة لمصدر الضوء عند المستوى البؤري.
- التلسكوبات التي تستخدم العدسات هي تلسكوبات كاسرة، وتلك التي تستخدم المرايا هي عاكسات.

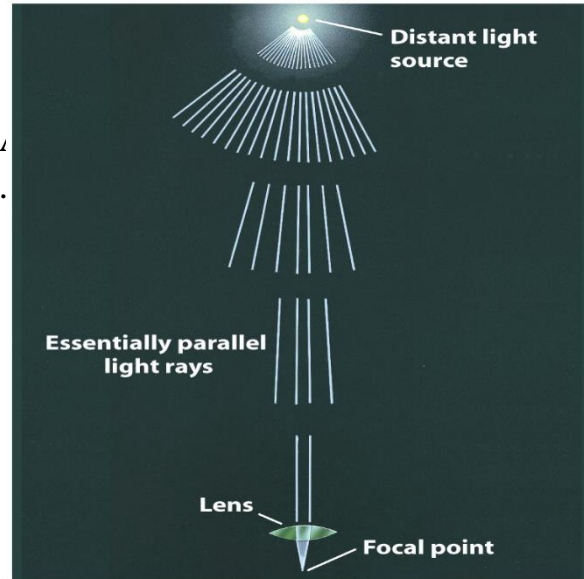
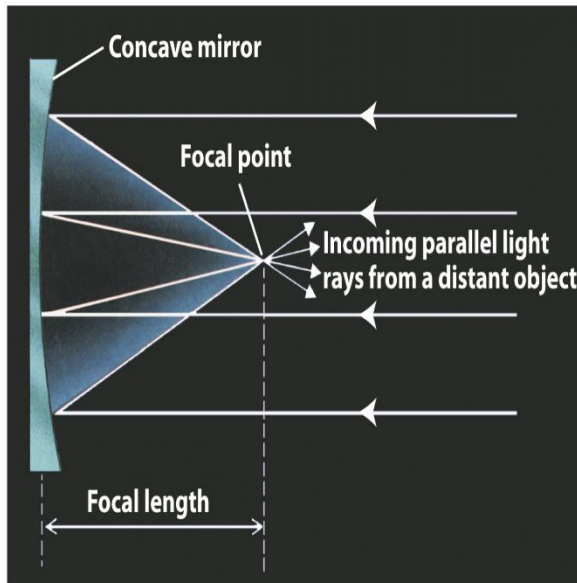

There are three basic types of optical telescopes – Refractor, Newtonian reflector and Catadioptric. All of these telescopes are designed to collect light and bring it to a focus point so that it can be magnified by an eyepiece, however each design does it in a different manner. Each of the designs has the potential to perform very well, and all have their own virtues, as well as faults.

تقنيات البصريات

1-The Refractor,

also known as the dioptrics, is a telescope that uses lenses to refract, (bend), the light that it collects. This refraction causes parallel light rays that converge at a focal point at the opposite end, where they can be magnified by an eyepiece. The large lens at the front is called the objective lens. The objective lens usually comprises of two or more individual lenses that are bonded and or arranged together to make up what is called the objective lens cell. The glass material used can also vary which will help in the overall performance of the objective lens.

يُعرف أيضًا باسم الديوبتريكس، وهو تلسكوب يستخدم العدسات لكسراو ثني الضوء. وبالتالي تجميع أشعة ضوئية متوازية عند نقطة بؤرية في النهاية المعاكسة، حيث يمكن تكبيرها بواسطة العدسة. تسمى العدسة الكبيرة الموجودة في المقدمة بالعدسة الشيئية. تتكون العدسة الشيئية عادةً من عدستين فرديتين أو أكثر يتم ربطهما أو ترتيبهما معًا لتكوين ما يسمى بخلية العدسة الشيئية. يمكن أيضًا أن تختلف المواد الزجاجية المستخدمة مما يساعد في الأداء العام للعدسة الشيئية.

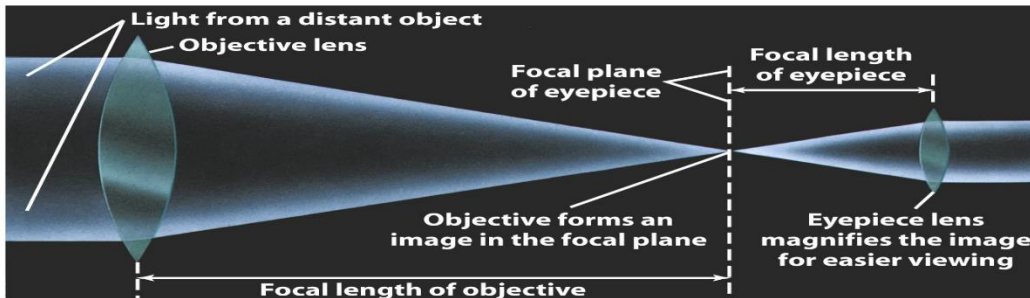
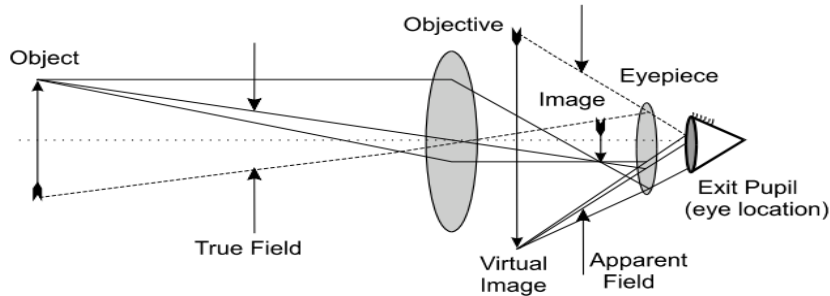

تقنيات البصريات

Problems with refractors:

- Chromatic aberration: focal length varies with wavelength
- Costly to make a large lens free of defects, such as bubbles
- Light is absorbed and scattered in the glass
- Heavy to support, distortion under weight

الانحراف اللوني: يختلف البعد البؤري باختلاف الطول الموجي

• تكون مكلفة لعمل عدسة كبيرة خالية من العيوب، مثل الفقاعات

• يتم امتصاص الضوء وينتشر في الزجاج

• التشويه نتيجة الوزن

2-Newtonian Reflector

The Newtonian Reflector, also known as catoptrics, is a telescope which uses a spherical or concave parabolic primary mirror to collect, reflect and focus the light onto a flat secondary mirror (diagonal). This secondary mirror in turn reflects the light out of an opening in the side of the tube and into an eyepiece for focus and magnification.

العاكس النيوتوني، المعروف أيضاً باسم كاتوبتريكس، هو تلسكوب يستخدم مرآة أولية مكافئة كروية أو مقعرة لجمع الضوء وعكسه وتركيزه على مرآة ثانوية مسطحة (قطرية). تعكس هذه المرآة الثانوية بدورها الضوء من فتحة في جانب الأنبوب إلى العدسة للتركيز والتكبير.

تقنيات البصريات

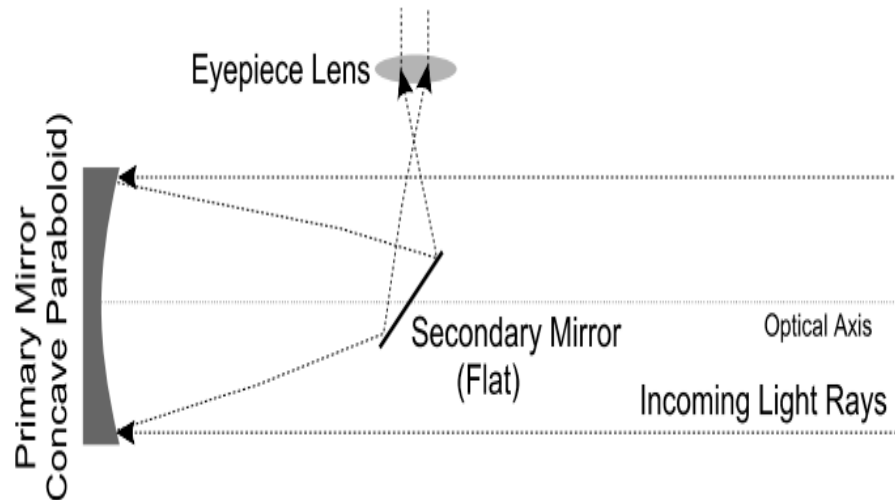

3-Catadioptrics

Catadioptrics are telescopes that use a combination of mirrors and lenses to fold the light path and direct it for focus and magnification through a hole in the primary mirror. There are two popular designs, the Maksutov-Cassegrain and Schmidt-Cassegrain. Both designs have similar advantages and disadvantages. In Maksutov designs the light enters a thick meniscus correcting lens with a strong curvature. The light then strikes the primary mirror and is reflected back up to the secondary mirror that reflects the light out an opening in the rear of the instrument. The secondary mirror is usually an aluminized spot on the back of the meniscus corrector. The Maksutov secondary mirror is usually smaller than the Schmidt's thus giving the Maksutov better resolution for planetary observing. The Maksutov is usually heavier than the Schmidt and the thicker correcting lens takes longer to reach thermal stability. In Schmidt designs the light enters a thin aspheric Schmidt correcting lens. The light then strikes the primary mirror and is reflected back up to the secondary mirror that reflects the light out an opening in the rear of the instrument. Schmidt's

usually have shorter focal lengths thus making them more suitable for fainter deep sky objects. The thinner corrector plate means the Schmidt is faster to reach thermal stability.

Telescope with Reflector mirror

1- Single-mirror systems:

A telescope with a single mirror is possible but has a very limited field. In such a system, the dominant aberration is coma and the angular length of the comatic image on the sky (in radians) is given by:

$$\text{Coma} = \frac{3}{16} \frac{\theta}{N_1^2}$$

where θ is the semifield angle (angle from the optical axis) in radians and N_1 is the mirror focal ratio ($N_1 = f_1/D$). On the ground, because of seeing, comatic images up to 0.5'' in length may be considered acceptable, so that the practical semifield angle expressed in arcminutes will be

$$\theta = 0.044 N_1^2$$

2-Two-mirror systems

Focus access is greatly improved by folding the beam and bringing the focus behind the primary mirror. In one form or another, a two-mirror system is the most widely used telescope configuration. It benefits from minimal reflection and central obstruction losses, is compact, and offers an external and very accessible focus. In its classical form, the two-mirror system consists of a parabolic primary and a conical secondary relaying the common focus to the final focus.

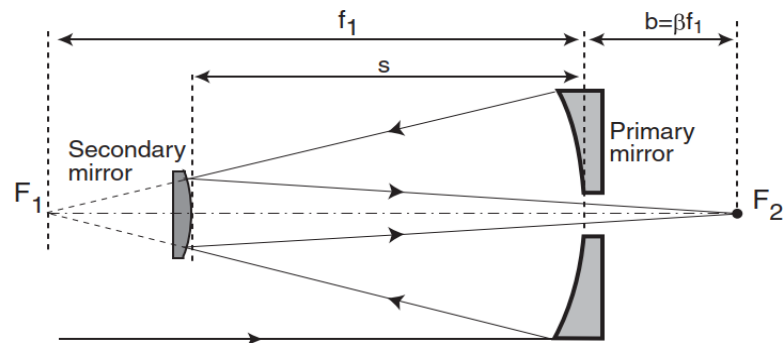

3- Three- and four-mirror systems

The Ritchey-Chrétien is an excellent and widely used combination, but interest has recently shifted to three and more mirror combinations because of the need for beam steering or wavefront correction. Wavefront correction and line-of-sight jitter compensation can be done with the secondary mirror, but it is generally preferable to use small mirrors that can be oriented or deformed rapidly with minimal negative dynamic effects. If a deformable mirror or fine steering mirror is used, it should be placed at a pupil. The exit pupil of the R-C combination is located in front of the secondary mirror and is virtual, but one can reimage that pupil in order to create a small, real, accessible pupil. This can be accomplished by introducing a single powered mirror (tertiary), provided that the system is used slightly off axis to avoid beam blockage, or by the use of two judiciously placed extra powered mirrors (tertiary and quaternary) to remain on axis . An example of a three-mirror combination is shown in figure.

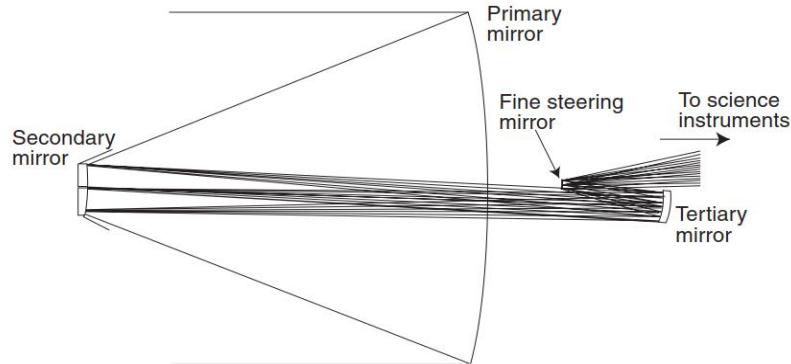

4-Systems with spherical mirrors

Spherical primary mirrors have the advantage of low-cost fabrication. But correction of the massive spherical aberration over a reasonable field is not trivial and generally requires three additional mirrors. An example is shown in figuer.

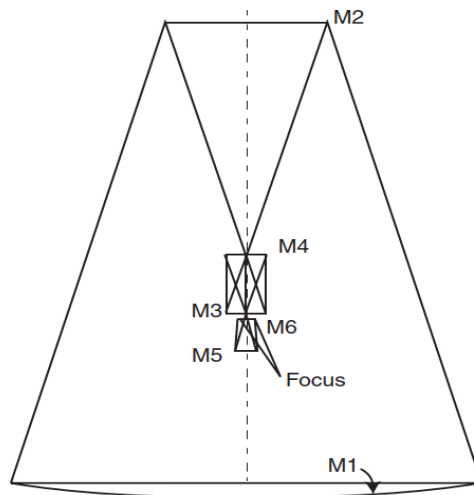

Figuer:Six-mirror system proposed for a 100-meter telescope with a spherical primary mirror. Two of the mirrors are simple flats.

تقنيات البصريات

Advantages of reflectors:

- The mirror is made to be highly reflective.
- Fewer problems with chromatic aberration, glass defects, support and distortion.
- Spherical aberrations can be corrected.

1-Total Internal Reflection

Total internal reflection is an optical phenomenon that happens when a ray of light strikes a medium at an angle larger than a particular critical angle with respect to the normal to the surface.

- The phenomenon of total internal reflection is used in many ophthalmic instruments such as gonioscope and fiber optic cables that have many medical as well as nonmedical uses.
- Critical Angle

Critical angle is the angle of incidence above which total internal reflection occurs. It is defined as the angle when the incidence ray is of such an angle that the refracted ray is at right angles to the normal.

قوانين الانعكاس والانكسار (Reflection's & Refraction's laws):

ينص قانون الانعكاس الأول على أن الشعاع الضوئي الوارد على سطح أملس شفاف، ينعكس

بزاوية انعكاس θ_i' مساوية لزاوية ورود θ_i . أي تتحقق العلاقة التالية: $\theta_i' = \theta_i$

The first law of reflection states that the incident ray of light on a smooth transparent surface is reflected at an angle of reflection θ_i' equal to the angle of the incidence θ_i . So, the following relation is achieved: $\theta_i' = \theta_i$

قانوني الانعكاس الأول والثاني.

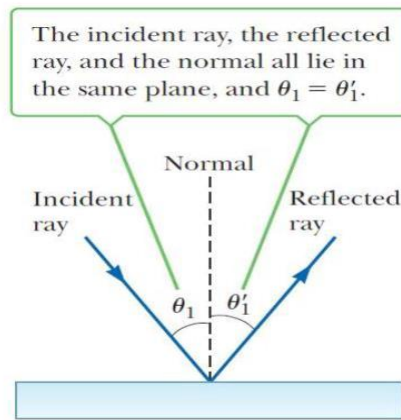

وينص قانون الانعكاس الثاني على أن كلاً من الشعاع الوارد على السطح الأملس والشعاع المنعكس عن هذا السطح يقع في نفس المستوي، بحيث أن الناظم على هذا السطح يفصل بين هذين الشعاعين .

The second law of reflection states that both, the incident ray on the smooth surface and the reflected ray from this surface, are at the same level so that the normal on this surface separates these two rays.

يعرف انكسار الضوء بأنه انحراف في اتجاه مسير الأشعة الضوئية عند عبورها سطح يفصل بين وسطين شفافين مختلفي الكثافة، وذلك بسبب سرعة الانتشار المختلفة للضوء في هذين الوسطين .

The refraction of light is known as a deviation in the direction of light rays when it crosses a surface, separating two transparent media with different densities, due to the different speed of diffusion of light in these two mediums.

ينص قانون الانكسار الثاني على أن كلاً من الشعاع الضوئي الوارد والشعاع الضوئي المنكسر واحد. والناظم على السطح تقع في مستوي

The first law of refraction states that both, the incident ray and the refracted one on the surface, are located in one level.

أما القانون الأول في الانكسار (قانون سنيل-ديكارت) فهو عبارة عن علاقة رياضية تربط ما بين زاويتي الورود والانكسار وقرين انكسار الوسطين المختلفين، ويعطى بالعلاقة التالية:

$$n_1 \cdot \sin i = n_2 \cdot \sin r$$

قانوني الانكسار الأول والثاني

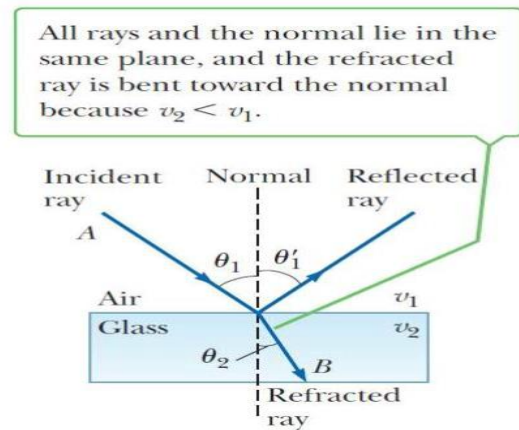

تدعى زاوية الورود المقابلة لزاوية الانكسار ($r = 90^\circ$) بالزاوية الحرجة

$$n \cdot \sin \theta_c = 1 \cdot \sin 90^\circ \Rightarrow \theta_c = \text{arc sin} \left(\frac{1}{n} \right) \quad \text{وتعطى بالعلاقة التالية:}$$

حيث تشير n إلى قرين انكسار وسط الورود (الماء أو الزجاج مثلاً) و 1 إلى قرين انكسار وسط الانكسار (الهواء).

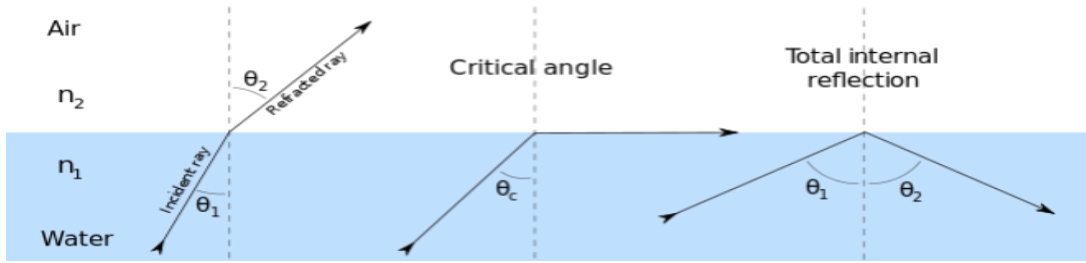

الزاوية الحرجة والانعكاس الداخلي الكلي للضوء

أما إذا تجاوزت زاوية الورود هذه الزاوية الحرجة، عندها لا يستطيع الشعاع الضوئي النفاذ من الوسط الأول باتجاه الوسط الثاني (أي أنه لا ينكسر) وإنما ينعكس كلياً نحو الداخل وفق ما يعرف بظاهرة الانعكاس الداخلي الكلي (Total internal reflection)، كما هو الحال في الألياف الضوئية.

The angle of incidence corresponding to the angle of refraction ($r = 90^\circ$) is called the critical angle, and is given via the following relation:

$$\sin 90^\circ = n \cdot \sin \theta_c \Rightarrow \theta_c = \text{arc sin} \left(\frac{1}{n} \right)$$

Index of refraction.

The two transparent optical media that form an interface are distinguished from one another by a constant called the index of refraction, generally labeled with the symbol n . The index of refraction for any transparent optical medium is defined as the ratio of the speed of light in a vacuum to the speed of light in the medium, as given in Equation:

$$n = \frac{c}{v}$$

where c = speed of light in free space (vacuum)

v = speed of light in the medium

n = index of refraction of the medium

The index of refraction for free space is exactly *one*. For air and most gases it is very nearly one, so in most calculations it is taken to be 1.0. For other materials it has values greater than one. Table 1-1 lists indexes of refraction for common materials.

Table 1-1 Indexes of Refraction for Various Materials at 589 nm

Substance	n	Substance	n
Air	1.0003	Glass (flint)	1.66
Benzene	1.50	Glycerin	1.47
Carbon Disulfide	1.63	Polystyrene	1.49
Com Syrup	2.21	Quartz (fused)	1.46
Diamond	2.42	Sodium Chloride	1.54
Ethyl Alcohol	1.36	Water	1.33
Gallium Arsenide (semiconductor)	3.40	Ice	1.31
Glass (crown)	1.52	Germanium	4.1
Zircon	1.92	Silicon	3.5

The greater the index of refraction of a medium, the lower the speed of light in that medium and the more light is bent in going from air into the medium. Figure down shows two general cases, one for light passing from a medium of lower index to higher index, the other from higher index to lower index. Note that in the first case (lower-to-higher) the light ray is bent toward the normal. In the second case (higher-to-lower) the light ray is bent away from the normal. It is helpful to memorize these effects since they often help one trace light through optical media in a generally correct manner.

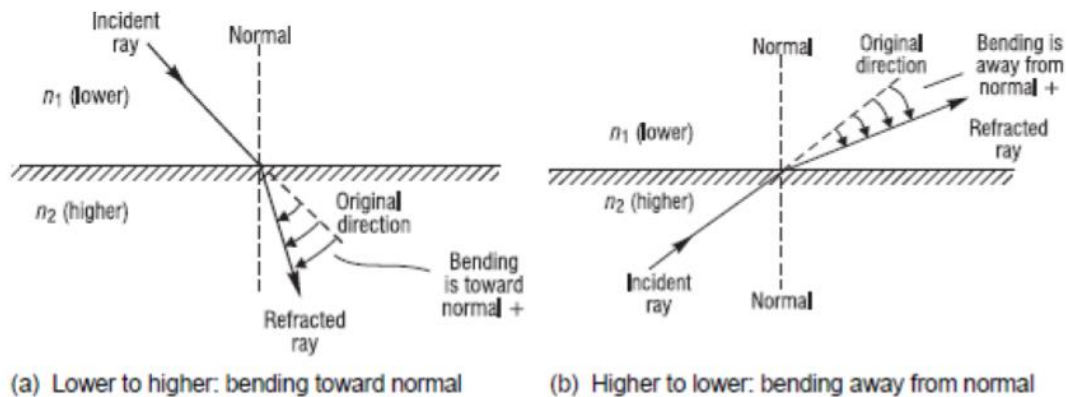

Figure: Refraction at an interface between media of refractive indexes n_1 and n_2

The eye structure:

Three layers of human eye

The eyeball has three coats as given below.

External fibrous coat

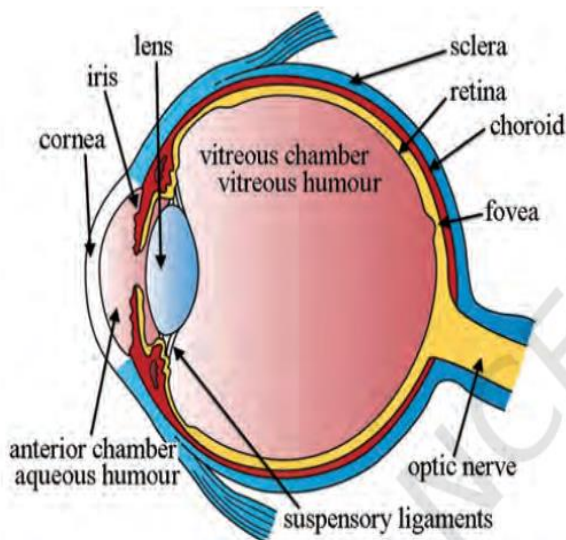

Fig. 1.1: Structure of Eye

The anterior, transparent, one-sixth part of the eyeball is called cornea. This refracts the rays of light into the eye. Cornea further extends with a membranous structure called conjunctiva. The connecting area of cornea and conjunctiva is limbus. External fibrous coat is formed of cornea and sclera.

Middle vascular coat

This coat is formed by the iris, ciliary body and choroid (anterior to posterior). This coat is vascular and pigmented, underlying the sclera.

Internal nervous coat

Internal nervous coat is formed of retina. The retina receives an inverted image of the objects seen. These images are conducted to the brain through a nerve called the optic nerve, which is connected at the posterior end of the eyeball.

Parts of human eye

(a) Anterior chamber: It is the one-third part of the eyeball which is bound by the cornea anteriorly, and the lens posteriorly. It contains the iris and a fluid called the aqueous humour.

(b) Posterior chamber: It forms the rest of the two-thirds of the eyeball, bound by the intraocular lens anteriorly and optic nerve head and retina posteriorly. It contains a gelly-like fluid called vitreous humour.

(c) Pupil: It is an aperture of variable size in the centre of iris, which regulates the amount of light entering the eyeball.

(d) Iris: It is the coloured membrane behind the cornea and in point of lens with an aperture of variable size called pupil. It has a circular and long muscle fibre. Iris is attached to the ciliary body.

(e) Lens: It is a transparent, biconvex structure situated between the iris and vitreous humour. Its function is to focus the luminous rays; these rays form a perfect image on the retina. With age, the central portion of the lens compresses by the surrounding fibres and results in opacity, which is called cataract.

Blind spot

The beginning of the optic nerve in the retina is called the optic nerve head or optic disc. Since there are no photoreceptors (cones and rods) in the optic nerve head, this area of the retina cannot respond to light stimulation. As a result, it is known as the 'blind spot', and everybody has one in each eye.

(f) Vitreous humour: This is a gel-like substance which maintains the shape of the eyeball. It is also a refractive media.

(g) Retina: It is a transparent layer forming the inner coat of the eye, it supports the choroid layer. The rays of light, on entering the eyeball, converge and form an image on the fovea—the posterior part of the eye on retina.

(h) Sclera: It is the outermost coat of the eyeball. It maintains strength and structure of the eyeball. It is also known as the white of the eye.

(i) Cornea: It is the clear, transparent, anterior portion of the external coat of the eyeball. The rays of light enter this layer. Cornea accounts for two-thirds of the total optical power of the eye.

Field of vision

The field of vision is the area that is seen all around. The field of view of a human eye is 95° on the left or right of the eye, 75° downwards, 60° towards the nose, and 60° upwards (Fig.1.3). It is in this space that an object can be seen while the eye fixes upon one point. Fig. 1.3: Field of vision for human eye

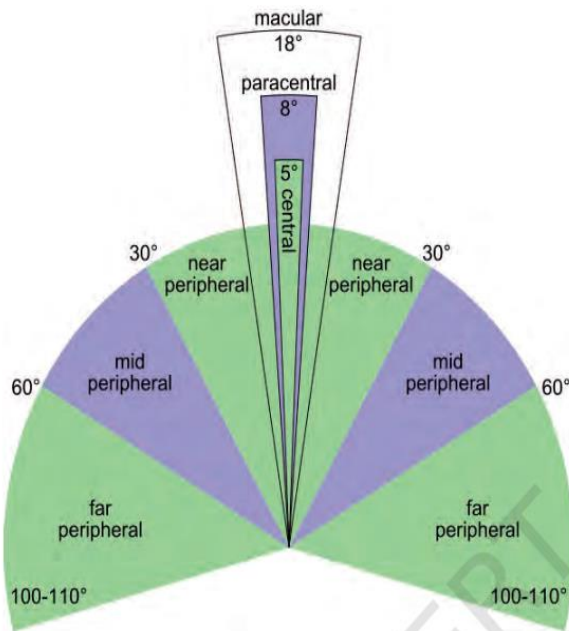

Fig. 1.3: Field of vision for human eye

Monocular vision

Monocular vision is the vision when each eye is used separately to see an object.

Binocular vision

Binocular vision is the vision when both eyes are used together to see an object. It gives perception of size, shape and depth of the object seen. As a result, the object seen by either eye is interpreted as a single image. Thus binocular vision is important, and required for drivers, pilots and such coordinated operations like catching a ball, etc.

Did you know?

Why do we have two eyes for vision and not just one?

There are several advantages of having two eyes instead of one. It gives a wider field of view. A human being has a horizontal field of view of about 1500 with one eye, and of about 1800 with both eyes. The ability to detect faint objects is, of course, enhanced with two detectors instead of one.

Some animals, usually prey animals, have both their eyes positioned on opposite sides of their heads to give the widest possible field of view. But our eyes are positioned on the front of our heads, and it thus reduces our field of view in favour of what is called stereopsis. Shut one eye and the world looks flat-two-dimensional. Keep both eyes open and the world takes on the third dimension of depth. Because our eyes are separated by a few centimetres, each eye sees a slightly different image. Our brain combines the two images into one, using the extra information to tell us how close or far away things are.

Types of eye movement

The movement of eyes is under voluntary control of the eyes. The types of movement include voluntary (both vertical and horizontal), tracking (both voluntary and involuntary) and convergence. The movements of the eye must conjugate in order to prevent double vision. The retina is a photo-sensitive layer that forms about 65% of inner surface of the eyeball. At the posterior end of the retina is a small elevation called the fovea or fovea centralis (Fig. 1.4). It has the sharpest vision and colour perception.

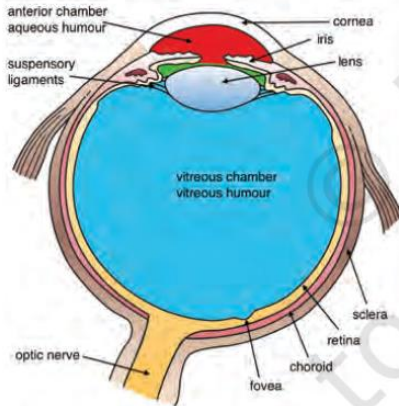

Fig. 1.4: Diagram showing Fovea

Muscles of the eye

The movement of eyeball is controlled by six muscles. Each eye moves in all the directions. The eyes also have a rotational movement. Horizontal eye movements are controlled by the medial and lateral rectus muscles, while superior rectus and inferior rectus muscles perform superior and inferior movement of the eyes. A machine is used by ophthalmologists to record muscle balances and movements of eyes it is called synaptophore (see Fig. 1.5).

Extra ocular cranial nerves and nuclei

There are three cranial nerves innervating eye muscles. The oculo motor nerve, (CNIII), innervates all of the extra ocular muscles. It also innervates the elevator of the upper lid. In addition, cranial nerves no. II, IV, V and VII also have play a role in other functions of the eyes, such as movement of upper lid, tear secretion, etc.

Tracking or smooth pursuit eye movements

We are able to move our eyes smoothly when tracking a moving object. This is an involuntary fixation on objects that are moving in relation to the head. The eyes have the tendency to track moving objects.



Fig. 1.5: Synaptophore machine

Retinal Image Size

The size of the image that falls upon the retina is influenced by the nature of the patient's refractive error and the manner in which it is corrected. Retinal image size is of clinical importance because clear, comfortable, and functional binocular vision requires the fusion of the images formed on the two eye's retinas. When the images are sufficiently unequal in size, fusion becomes difficult and the patient may manifest asthenopic and other symptoms. A difference between the retinal image size (or shape) of the two eyes is referred to as aniseikonia.

ويتأثر حجم الصورة التي تقع على الشبكية بطبيعة الخطأ الانكساري لدى المريض وطريقة تصحيحه. حجم الصورة الشبكية له أهمية سريرية لأن الرؤية الثنائية الواضحة والمریحة والوظيفية تتطلب دمج الصور المتكونة على شبكية العين. عندما تكون الصور غير متساوية في الحجم بما فيه الكفاية، يصبح الدمج صعباً وقد يظهر على المريض أعراض وهنية وأعراض أخرى. يُشار إلى الاختلاف بين حجم (أو شكل) الصورة الشبكية للعينين باسم aniseikonia.

SPECTACLE MAGNIFICATION

Both the refractive power and shape of a spectacle lens may affect retinal image size. Plus lens power causes angular magnification, while minus lens power causes minification. The change in retinal image size due to lens refractive power is referred to as the power factor. Lens shape also affects retinal image size. For our discussion, shape is defined as front surface power, thickness, and index of refraction. All these contribute to the shape factor magnification produced by a lens.

The power and shape factors are independent from one another. Consider two equally powered lenses (e.g., two +5.00 DS lenses). Because of their equal powers, both have the same power factor. If refractive power was the only consideration, both lenses would produce the same magnification. But if the two lenses

had different shapes, meaning that the front surface powers, thicknesses, or indices of refraction were different, they would cause unequal magnification because they have unequal shape factors.

In trying to understand the shape factor, it may be helpful to recall that a telescope, when focused for infinity, has no refractive power, yet produces angular magnification. It's possible to make a miniature Galilean telescope from a spectacle lens that has a plus front and minus back surface. Since this spectacle-telescope does not have any refractive power, it does not cause power magnification (the power factor is 1.0×), but it does have magnification due to its shape. A lens (such as the one we just described), which has no refractive power, but does produce angular magnification, is sometimes referred to as a size lens. Spectacle magnification (M_{spect}) can be expressed as follows:

$$M_{\text{spect}} = (M_{\text{power}}) (M_{\text{shape}})$$

where M_{power} is the power factor, and M_{shape} is the shape factor.

The power factor is calculated with the following formula:

$$M_{\text{power}} = \frac{1}{1 - dF_v}$$

where d is the vertex distance and F_v is the back vertex power.

The formula for the shape factor is

$$M_{\text{shape}} = \frac{1}{1 - \left(\frac{t}{n}\right) F_1}$$

where t is the lens thickness, n is the lens's index of refraction, and F_1 is the power of the front surface. Putting this all together, we have

$$M_{\text{spect}} = (M_{\text{power}})(M_{\text{shape}})$$

$$M_{\text{spect}} = \left(\frac{1}{1 - dF_v} \right) \left(\frac{1}{1 - \left(\frac{t}{n} \right) F_1} \right)$$

Let's see how we can use this formula. A polycarbonate lens has a power of +5.00 D and a front surface refractive power of +2.00 D. If the lens has a center thickness of 4.0 mm and the vertex distance is 14 mm, what is the magnification produced by the lens?

It's straightforward to substitute in the formula for spectacle magnification as follows:

$$M_{\text{spect}} = \left(\frac{1}{1 - dF_v} \right) \left(\frac{1}{1 - \left(\frac{t}{n} \right) F_1} \right)$$
$$M_{\text{spect}} = \left(\frac{1}{1 - (0.014 \text{ m})(+5.00 \text{ D})} \right) \left(\frac{1}{1 - \left(\frac{0.004 \text{ m}}{1.586} \right) (+2.00 \text{ D})} \right)$$
$$M_{\text{spect}} = (1.08)(1.01) = 1.09\times$$

The spectacle magnification produced by the lens is 1.09×. Of this, 1.08× is due to the power of the lens and 1.01× is due to its shape.

As we mentioned previously, two lenses with the same refractive power may have different spectacle magnifications. Let's consider another lens that has a power of +5.00 DS, but has a front surface power of +15.00 DS. We'll assume that the lens is

made of the same material and has the same center thickness and vertex distance. What magnification is produced by this lens?

$$M_{\text{spect}} = \left(\frac{1}{1 - dF_v} \right) \left(\frac{1}{1 - \left(\frac{t}{n} \right) F_1} \right)$$
$$M_{\text{spect}} = \left(\frac{1}{1 - (0.014 \text{ m})(+5.00 \text{ D})} \right) \left(\frac{1}{1 - \left(\frac{0.004 \text{ m}}{1.586} \right) (+15.00 \text{ D})} \right)$$
$$M_{\text{spect}} = (1.08)(1.04) = 1.12$$

Although each of these +5.00 DS lenses has a power factor of 1.08×, they produce different spectacle magnification because the shape factors are different (1.01× vs. 1.04×). The lens that has the more curved front surface results in more magnification. When two lenses of equal power are made of the same material and have the same thickness and vertex distance, the lens with the more curved front surface will produce greater magnification. (Keep in mind that almost all spectacle lenses have a plus front surface.1)

RETINAL IMAGE SIZE IN UNCORRECTED AMETROPIA

Ametropia

The eye is a sophisticated optical system constituted of multiple refracting surfaces, and to solve certain optical problems it is necessary to consider the optical properties of the eye in all their complexity. For many problems and clinical cases, however, a satisfactory solution can be obtained by using a simplified optical model of the eye, referred to as a schematic eye.

العين عبارة عن نظام بصري متطور يتكون من أسطح متعددة منكسرة، ولحل بعض المشاكل البصرية من الضروري مراعاة الخصائص البصرية للعين بكل تعقيداتها. ومع ذلك، بالنسبة للعديد من المشاكل والحالات السريرية، يمكن الحصول على حل مرضٍ باستخدام نموذج بصري مبسط للعين، يشار إليه بالعين التخطيطية.

There are various schematic eyes. For our purposes, we will work with what is called the reduced eye, 1. It consists of a single spherical refracting surface1 with a radius of curvature of 5.55 mm that separates air from aqueous, which is assumed to

have an index of refraction of 1.333. There is a single nodal point located at the center of curvature of the refracting surface. As is the case for all spherical refracting surfaces, the principal planes are coincident with the surface. The distance from the surface to the retina—the axial length—is 22.00 mm.

هناك عيون تخطيطية مختلفة ولأغراضنا، سنعمل مع ما يسمى بالعين المخفضة، 1. وهي تتكون من سطح انكسار كروي واحد يبلغ نصف قطر انحناءه 5.55 ملم، ويفصل الهواء عن الماء، والذي يفترض أن يكون معامل انكساره 1.333. هناك نقطة عقدية واحدة تقع في مركز انحناء السطح المنكسر. كما هو الحال بالنسبة لجميع الأسطح الكروية المنكسرة، فإن المستويات الرئيسية تتوافق مع السطح. المسافة من السطح إلى الشبكية – الطول المحوري – 22.00 ملم.

The reduced eye is emmetropic, meaning that as illustrated in Figure 7-2, light rays originating at infinity are focused on the retina.² Let's look at this in more detail. First, we'll determine the power of the reduced eye. Since we know its radius of curvature and the relevant refractive indices, the surface's refractive power can be calculated as follows:

$$F = \frac{n' - n}{r}$$
$$F = \frac{1.333 - 1.000}{0.00555}$$
$$F = +60.00 \text{ D}$$

Ametropia is due to a mismatch between the eye's refractive power and its axial length. The retinal image size in uncorrected ametropia depends on whether the ametropia is axial or refractive in nature.

The reduced eye has a length of 22.22 mm. When the eye is longer than this, it is said to have axial myopia, and when it is shorter, axial hyperopia. Most myopia is axial in nature. If the eye is more powerful than the reduced eye, which has a power of +60.00 D, the condition is called refractive myopia, and when the eye is weaker than +60.00 D, the condition is refractive hyperopia. Either myopia or hyperopia can have a mixture of axial and refractive components.

Let's first look at axial ametropia. Figure 1 shows three axial lengths that would be expected in hyperopia, emmetropia, and myopia. Suppose the eye is viewing an arrow. A light ray emerging from the tip of the arrow passes undeviated through the eye's nodal point and contributes to the retinal image. Note that as the eye's axial length increases, the size of the retinal image also increases. This tells us that in uncorrected axial myopia, retinal image size is larger than in emmetropia and that in uncorrected axial hyperopia, it is smaller than in emmetropia.

Now let's see what happens to retinal image size in uncorrected refractive ametropia. As illustrated in Figure 2A, the eye has a fixed length. When the refractive power of the eye increases (as in myopia) or decreases (as in hyperopia), the image becomes blurred, but its size does not change. Think of a projector that focuses an arrow on a screen. If we adjust the focus so that the image is blurred, as in Figure 2B, the blurred image, as measured from the centers of the blur circles, is the same size as the focused image

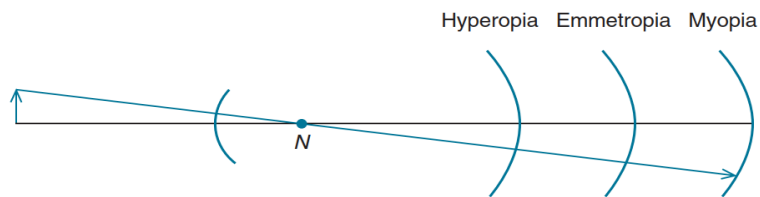
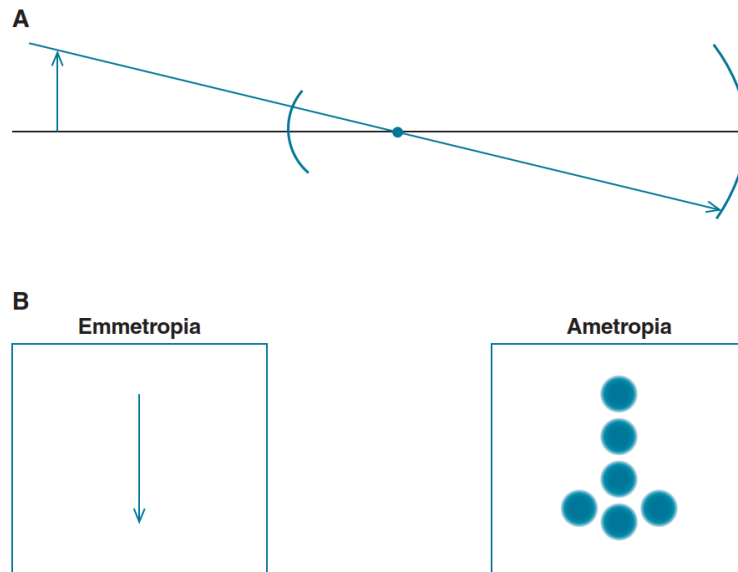

Fig 1. In axial ametropia, the retinal image size increases as the eye's axial length increases.



FigA. In refractive ametropia, image blur is not due to the axial length being too short or long. **B.** Refractive ametropia results in a blurred retinal image, but does not affect the image size

RETINAL IMAGE SIZE IN CORRECTED AMETROPIA

Before talking about retinal image size in corrected ametropia, let's recap what we've learned so far about spectacle magnification and retinal image size in uncorrected ametropia:

- A plus spectacle lens causes magnification.
- A minus spectacle lens causes minification.
- A contact lens causes no magnification (or minification).
- In axial myopia, the retinal image is larger than in emmetropia and in axial hyperopia, it is smaller than in emmetropia.
- In refractive myopia and hyperopia, the retinal image is the same size as in emmetropia.

TABLE 1. RETINAL IMAGE SIZE IN AMETROPIA

Condition	Retinal Image Size When the Ametropia Is		
	Uncorrected (mm)	Corrected with a Contact Lens (mm)	Corrected with a Spectacle Lens* (mm)
Emmetropia	x	x	x
Axial myopia	$>x$	$>x$	x
Refractive myopia	x	x	$<x^{**}$
Axial hyperopia	$<x$	$<x$	x
Refractive hyperopia	x	x	$>x^{**}$

*Spectacle lens located at anterior focal point of eye.

**The retinal image size in uncorrected refractive myopia and hyperopia is the same as in emmetropia. Correction of refractive myopia with a spectacle lens causes minification, while correction of refractive hyperopia with a spectacle lens causes magnification.

What does this imply about retinal image size in corrected ametropia?

We can assume that the retinal image size will be about the same as in emmetropia when:

- Axial ametropia is corrected with spectacles (A minus lens minifies the enlarged image found in uncorrected axial myopia and a plus lens magnifies the diminished image found in uncorrected axial hyperopia.)
- Refractive ametropia is corrected with contact lenses (The retinal image size in uncorrected refractive myopia and hyperopia is the same as in emmetropia, and a contact lens doesn't change this.)

For the retinal image in corrected axial ametropia to be exactly the same size as in the emmetropic eye, the spectacle lenses should be positioned at the anterior focal point of the eye, which is 16.7 mm (i.e., $1000/60.00 \text{ D} = 16.7 \text{ mm}$) anterior to the

reduced eye's front surface. This is referred to as Knapp's law. In clinical practice, it is not necessary for the vertex distance to be exactly 16.7 mm. Retinal image size in uncorrected and corrected ametropia is summarized in Table 1.

What are the clinical implications of all this? Consider anisometropia, a relatively prevalent condition in which the two eyes have different refractive errors. Depending on the magnitude and nature of the anisometropia (axial or refractive) and the manner in which it is corrected (spectacles or contact lenses), the retinal images in the two eyes may be different sizes, a condition we previously referred to as aniseikonia.

Let's look at an example. A patient has the following refractive error:

OD -2.00 DS
OS -5.00 DS

Since the corneas of the two eyes have the same power, we can assume that the anisometropia is axial in nature. The left eye has a longer axial length, making its uncorrected retinal image larger than the right eye's. Correction with spectacle lenses would minimize the images of both eyes, but since the left lens is more minus, it would cause more minification. As a result, both eyes would have image sizes equal to that found in emmetropia. Does this mean that we should not consider prescribing contact lenses for this patient? Not really. The visual system is remarkably adaptable, and patients with axial anisometropia generally do well with contact lenses. If a patient with significant axial anisometropia cannot adapt to contact lenses, however, it is possible that their symptoms are related to aniseikonia.

We'll do one more case. A patient has no visual discomfort when she wears contact lenses, but has never felt comfortable wearing her current polycarbonate spectacles, which have the following powers:

OD -5.00 DS

OS -2.50 DS

Both of these lenses have front curvatures of +2.00 D and center thicknesses of 1.5 mm. Keratometry readings reveal that the right cornea is about 4.00 diopters stronger than the left. Assuming that the spectacle lens powers are appropriate and that the patient's symptoms are due to aniseikonia, how could we design her new spectacle lenses to minimize the symptoms?

This is a case of refractive anisometropia. When not wearing any correction or while wearing contact lenses, the retinal images are equal in size. Wearing spectacles, however, causes the right eye's retinal image to be smaller than the left eye's image. Assuming a vertex distance of 14 mm, the power factor for the right lens is

$$\text{Power factor} = \frac{1}{1 - dF_v}$$

$$\text{Power factor} = \frac{1}{1 - (0.014 \text{ mm})(-5.00 \text{ D})} = 0.935 \times$$

For the left lens, the power factor is

$$\text{Power factor} = \frac{1}{1 - (0.014 \text{ mm})(-2.50 \text{ D})} = 0.966 \times$$

When both lenses have a front surface curvature of +2.00 D and a center thickness of 1.5 mm, the shape factor for each lens is

$$\text{Shape factor} = \left(\frac{1}{1 - \left(\frac{t}{n}\right) F_1} \right)$$

$$\text{Shape factor} = \left(\frac{1}{1 - \left(\frac{0.0015}{1.586}\right) + 2.00 \text{ D}} \right) = 1.00 \times$$

Since the total spectacle magnification is the product of the power and shape factors, a front surface power of +2.00 D and a center thickness of 1.5 mm result in magnification of 0.935× for the right eye and 0.966× for the left eye.

We can compensate for this difference by changing the shape factor for the right lens. By increasing its curvature and thickness, we can increase its magnification relative to the left lens.³ Let's select a front surface curvature of +10.00 D and a thickness of 5.0 mm for the right lens. The shape factor is

$$\text{Shape factor} = \left(\frac{1}{1 - \left(\frac{0.005}{1.586} \right) + 10.00 \text{ D}} \right) = 1.03 \times$$

The total spectacle magnification for the right lens is

$$M_{\text{spect}} = (M_{\text{power}})(M_{\text{shape}})$$
$$M_{\text{spect}} = (0.935)(1.03) = 0.963 \times$$

With this design, the spectacle magnification of the right lens (0.963×) is very close to that produced by the flatter, thinner left lens, thereby all but eliminating the aniseikonia. The right lens, however, would look much different than the left lens, and this may not be cosmetically acceptable to the patient. When the shape of a lens is intentionally manipulated to affect retinal image size, the lens is sometimes referred to as an iseikonic lens.

SUMMARY

The retinal image size depends on the nature of the ametropia (axial or refractive) and how it is corrected (contact lenses or spectacles). In uncorrected axial myopia, the retinal image is larger than in emmetropia, while in uncorrected axial hyperopia, it is smaller than in emmetropia. Correction with a contact lens does not alter this, whereas correction with a spectacle lens makes the retinal images in axial myopia and hyperopia about the same size as in emmetropia. In comparison, the retinal image sizes in uncorrected refractive myopia and hyperopia are both equal to that in emmetropia. Again, correction with a contact lens does not alter this, whereas

a minus spectacle lens used to correct refractive myopia makes the image smaller than in emmetropia, and a plus spectacle lens used to correct refractive hyperopia makes the image larger than in emmetropia. The correction of anisometropia may result in aniseikonia. In the case of axial anisometropia, one would expect that correction with spectacles would be preferable to contact lenses, but this often is not the case. When prescribing spectacles for refractive anisometropia, it's sometimes necessary to minimize the difference in spectacle magnification between the two eyes. This may require special lens designs in which front surface power and lens thickness are selected for this purpose. Commonly, however, modest adjustments in front surface power and thickness, while minimizing vertex distance, are sufficient.

يعتمد حجم صورة الشبكية على طبيعة ضعف البصر (المحوري أو الانكساري) وكيفية تصحيحه (العدسات اللاصقة أو النظارات). في قصر النظر المحوري غير المصحح، تكون صورة الشبكية أكبر مما هي عليه في عمى البصر، بينما في بعد البصر المحوري غير المصحح، تكون أصغر مما هي عليه في عمى البصر. التصحيح باستخدام العدسات اللاصقة لا يغير هذا، في حين أن التصحيح باستخدام عدسة النظارات يجعل صور الشبكية في قصر النظر المحوري وبعد البصر بنفس الحجم تقريبًا كما في قصر النظر المحوري. بالمقارنة، فإن أحجام صور شبكية العين في قصر النظر الانكساري غير المصحح وطول النظر كلاهما مساوية لتلك الموجودة في عمى البصر. ومرة أخرى، التصحيح باستخدام العدسات اللاصقة لا يغير هذا، في حين أن عدسة النظارة السالبة المستخدمة لتصحيح قصر النظر الانكساري تجعل الصورة أصغر مما هي عليه في بعد البصر الانكساري، والعدسة الزائدة المستخدمة لتصحيح بعد النظر الانكساري تجعل الصورة أكبر من تلك الموجودة في بعد البصر الانكساري. وقد يؤدي تصحيح تباين البصر إلى تفاوت البصر. في حالة تباين الانكسار المحوري، يتوقع المرء أن التصحيح باستخدام النظارات سيكون أفضل من العدسات اللاصقة، ولكن هذا ليس هو الحال في كثير من الأحيان. عند وصف النظارات لعلاج تباين الانكسار الانكساري، يكون من الضروري في بعض الأحيان تقليل الاختلاف في تكبير النظارات بين العينين. وقد يتطلب ذلك تصميمات خاصة للعدسات يتم فيها اختيار قوة السطح الأمامي وسمك العدسة لهذا الغرض. ومع ذلك، عادةً ما تكون التعديلات المتواضعة في قوة السطح الأمامي وسمكه، مع تقليل مسافة الرأس، كافية

Coherent Sources:

- Two waves are said to be coherent , if they emit same frequency or wave length and are in phase or constant phase difference.

CONDITIONS FOR OBTAINING COHERENT SOURCE:

- Coherent sources are obtained from single source.
- The source must emit mono chromatic light.
- The path difference between light sources must be very small.

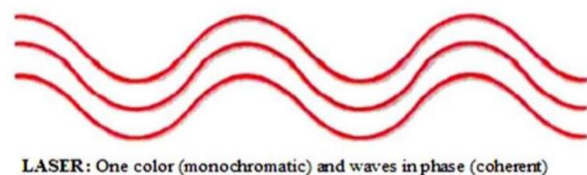
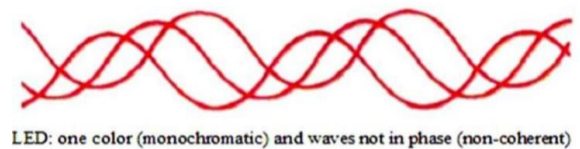
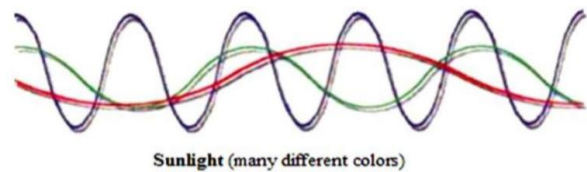
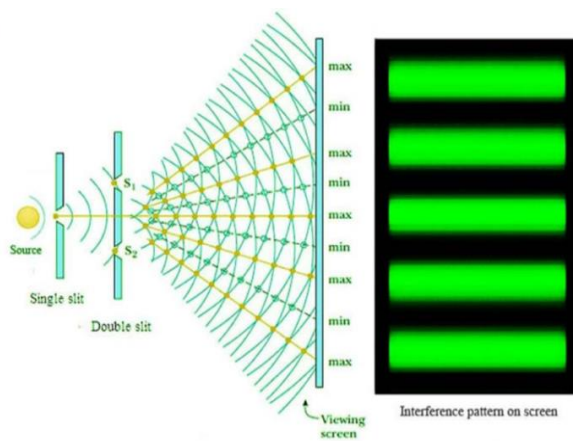
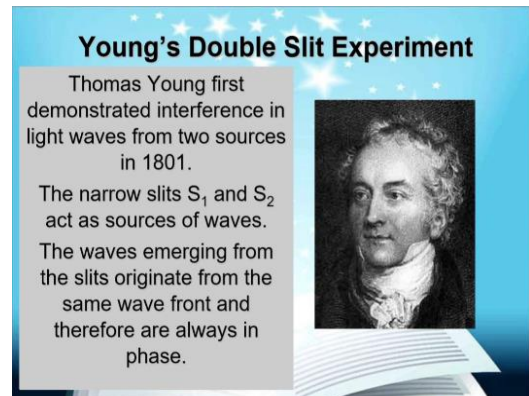
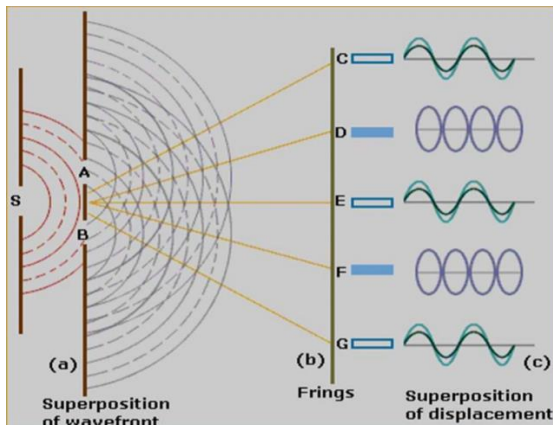

- **Why can't two sources behave as coherent sources?**

Two different sources can never produce waves of same phase because each source of light contains infinite number of atoms and the waves which are emitted by them will not be in phase. The atoms after absorbing energy go to excited states and emit radiations when fall back to ground state.

- **Single slit and double slit**

Parallel light rays which pass through a small aperture begin to diverge and interfere with one another. This becomes more significant as the size of the aperture decreases relative to the wavelength of light passing through, but occurs to some extent for any size of aperture or concentrated light source.

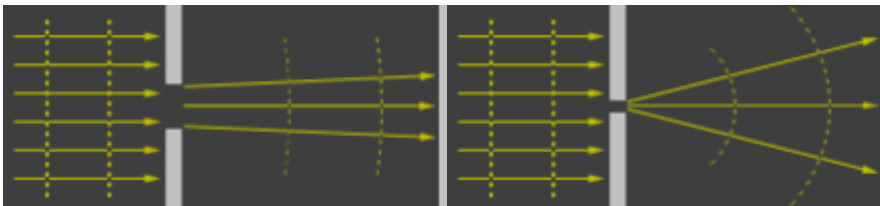

Since the divergent rays now travel different distances, some move out of phase and begin to interfere with each other-- adding in some places and partially or completely canceling out in others. This interference produces a diffraction pattern with peak light intensities where the amplitude of the light waves add, and less light where they cancel out. If one were to measure the intensity of light reaching each position on a line, the data would appear as bands similar to those shown below.

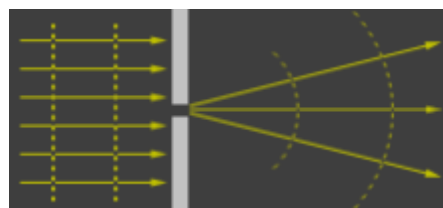

Single slit : Diffraction phenomena can be clearly demonstrated by means of the intensive and coherent light of a laser. Diffraction of the incoming parallel light at

the slit aperture causes the light to propagate also in the geometrical shadow of the slit diaphragm. Moreover, a pattern of bright and dark fringes is observed on the screen. This cannot be explained by the laws of geometrical optics.

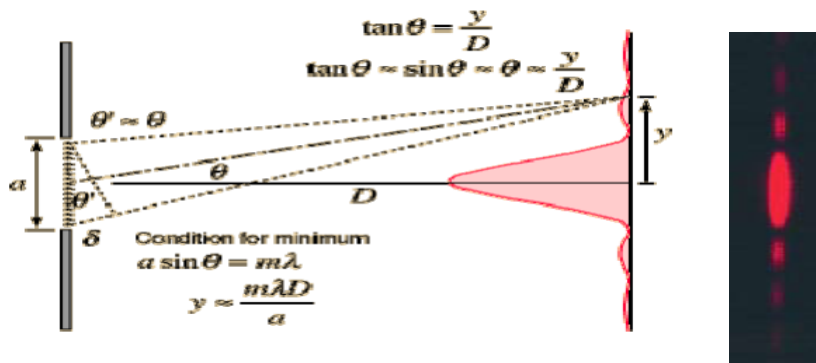

Fig. 1 Schematic representation for the diffraction of light at a slit

a : slit width

D : distance between the screen and the slit

y : distance of the 2nd intensity minimum from the centre

θ : direction in which the 2nd destructive interference is observed

δ : path difference

m : the order of interference pattern

An explanation is only possible if wave properties are attributed to the light and if the diffraction pattern observed on the screen is considered as a superposition of a (infinitely) great number of partial bundles coming from the slit aperture. In certain directions, the superposition of all partial bundles leads to destructive or constructive interference, respectively. Fig. 1 suggests a simple approach to make it plausible that dark fringes occur at positions where every partial bundle from one half of the slit is associated with exactly one partial bundle from the other half so that they cancel each other. For the partial bundles coming from the slit under the angle θ , this is true in those cases where path difference δ between the central ray and the rim ray is an integer multiple m of half the wavelength λ of the light:

$$\delta = m \cdot \frac{\lambda}{2} \quad m = 1,2,3,\dots \quad (1)$$

$$\text{where } \delta = \frac{a}{2} \sin \theta \quad (2)$$

Using trigonometry, we can show that:

$$\tan \theta = \frac{y}{D}$$

For small diffraction angles the following relation holds approximately:

$$\sin \theta \approx \tan \theta \approx \frac{y}{D} \quad (3)$$

Thus, from the condition for destructive interference (1), the wavelength is obtained:

$$\lambda = \frac{y}{m} \cdot \frac{a}{D}$$

This relation establishes a connection between the wavelength λ and the geometry of the experiment. If the slit width a is known, Eq. (4) enables the wavelength λ to be determined. On the other hand, it is possible to determine the size of a diffraction object like hair or string from a diffraction experiment with monochromatic light of known wavelength.

- **Effect of coherent light on human eye:**

WHAT SPECIFIC PORTIONS OF THE ENVIRONMENTAL ELECTROMAGNETIC SPECTRUM CAUSE EYE DAMAGE?

With sufficient magnitude almost all portions of the electromagnetic spectrum can cause damage to the eye. For example: Lasers of a wide variety of wavelengths from the short wavelength UV (Excimer laser for LASIK) through the visible spectrum (Argon laser for diabetic retinopathy) to short wavelength IR (YAG laser for iridotomy and capsulectomy) are used to “damage” eye tissue in the treatment of various eye conditions.

However, in our “natural” environments with natural and man-made lights, the most offending portions of the EM spectrum are the UV-A (315 nm to 400 nm), UV-B (280 nm to 315 nm), and “blue-light” portion of the visible spectrum (380 nm to 500 nm). Our atmosphere generally protects us from UV radiation below 280 nm. Additionally, as the cornea and crystalline lens absorbs almost all natural UV radiation, UV radiation is thought to cause damage to the anterior eye, while short visible light (“blue-light”) can cause damage to retinal structures. Also, as the

damaging processes are thought to be at least partially photochemical in nature, the damaging effects can be cumulative in nature, which may compound across one's lifetime.

- ***Solar Energy Technology Choice Development***

The annual solar radiation which has an average of 4 - 7.5 KW/m² is available in Middle East and North Africa (MENA) countries such as Egypt and Saudi Arabia. Moreover, the above average solar radiation is approximately five times higher than the average solar radiation in Europe which is around 1 KW/m² and in Greece is around 1.7 KW/m². Hence, solar energy can be nominated as the promising source of renewable energy in this region

The goal of this investigation is to study the proper solar energy technology and to match it with the applications. SE technologies discussed [1-10] may be

classified into:

I. Solar thermal energy conversion is to convert solar

radiation to:

1- Heat water. This application type has two main technologies:

(a) Flat plate collector.

(b) Evacuated tubes collector.

2- Electricity via converting water to steam.

II. Photovoltaic applications, which means the direct conversion of solar irradiance to electricity. The cost of each technology represents the main obstacle facing the spread of such technology. The efficiency of different technologies varies between 6 - 44.4% for amorphous silicon-based solar cells with multiple-junction production cells with enormous cost variation. Some of these technologies are already commercialized in the market and others are in R&D phase. This makes SE technology choice a real problem related to the application [2].

- **Solar Photovoltaic System**

Photovoltaic power generation is a method of producing electricity, using solar cells. A solar cell is a device that /converts solar optical energy (solar radiation) directly into electrical energy. It is essentially a semiconductor device fabricated in a manner which generates a voltage when solar radiation falls on it.

Semiconductor Materials and Doping

A few semiconductor materials such as silicon (Si), cadmium sulphide, (CdS) and gallium arsenide (GaAs) can be used to fabricate solar cells. Semiconductors are divided into two categories: intrinsic (pure) and extrinsic, An intrinsic semiconductor has negligible conductivity, which is of little use. To increase the conductivity of an intrinsic semiconductor, a controlled quantity of selected impurity atoms is added to it to obtain an extrinsic semiconductor. The process of adding the impurity atoms is called doping.

a pure semiconductor, electrons can stay in, one of the two energy bands the conduction band and the valence band, The conduction band has electrons at a higher energy level and is not fully occupied, while the valence band possesses electrons at a lower-energy level but is fully occupied (Figure 3-1). The energy level of the electrons differs between the two bands and this difference is called the band gap energy.

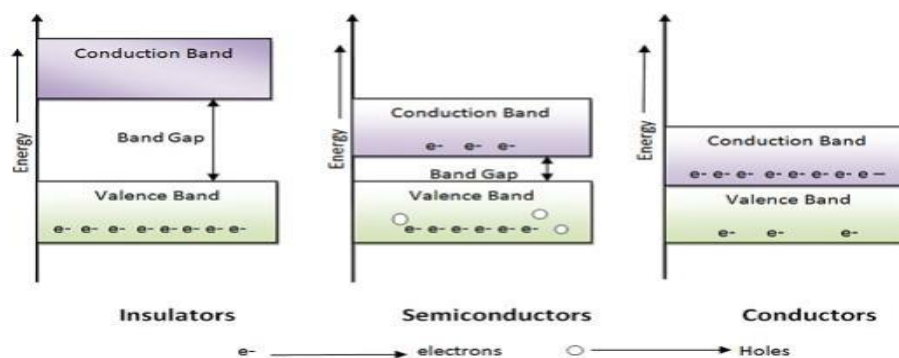

- **Nanotechnology in renewable energy systems**

Nanotechnology is extremely important for efficient use, storage and production of energy. In this context, it is one of the main objectives to contribute to cleaner, sustainable, production by reducing energy use with raw materials. Thus, it is ensured to prevent waste from various sources and to develop environmentally friendly production systems that produce less waste.

The future sustainable development of society is based on renewable and environmentally friendly alternative energy sources. These energy sources can be listed as solar, wind, biomass, hydrogen and geothermal energy. These clean sources can be used alternatively to traditional energy sources. These sources are expected to provide 50% of the world's primary energy by 2040

Nanotechnology in the field of renewable energy sources, which is thought to be a solution to global warming that disrupts the natural balance, is one of the popular topics of today's technology.

Nanotechnology has provided new possibilities to solve problems that need to be overcome in the field of energy. One of the biggest problems in energy resources today is the lack of alternative energy resources or the efficiency of the resources available cannot be brought to the desired level.

Problems arising during the storage and transportation of the energy obtained cause energy losses. In addition, the energy obtained cannot be evaluated efficiently by the users and there is a lot of energy loss during the usage phase. For the solution of these problems, intensive work is being carried out in line with the innovations brought by nanotechnology

1-Applications of Nanoparticles in Batteries

applications and solutions. When the size of the bulk materials is reduced to the nanometer sizes, the quantum mechanical properties of electrons contribute to their behavior as they dominate the physical properties. Electrons are confined in all three dimensions. The quantum mechanical properties of electrons contribute to their behavior and dominate the physical properties of electrons confined in all three

dimensions. Using nanoparticles in a battery increases the contact area between the electrode and the electrolyte. This is important since electrolytes will prevent ions from conducting ions. Nanoparticles provide penetration length and stress modulation, producing high power and capacity. Different types of nanoparticles could be used in batteries, such as Nano carbons, graphene, carbon nanotubes, etc.. It is important to use inexpensive, low-conductivity nanoparticles in battery electrodes, such as lithium iron phosphate and lithium titanate. This resulted in commercializing batteries with those substances. Batteries are used in cellular packages, mobiles, laptops, computers, etc.

Using NPs in batteries opens up a wide area of research for researchers, increasing the efficiency, weight reduction, and life expectancy of this type of battery. Nanoparticles may be exploited to enhance the electrochemical systems. It could be used in lithium batteries in two general groups:

- 1- Enhancing the overall performance of battery constituents such as anode and cathode.
- 2- Creating a variety of batteries, including flexible batteries, Nano-batteries, and 3D batteries. Inert Nanomaterials could be used to improve conductivity. It was found that nanoparticles can provide high capacity and power by providing penetration length and stress regulation. Furthermore, it is a safe, stable, and low-cost substance.

1-Nanomaterials to hydrogen production

consisted of a TiO₂ anode and Pt cathode for oxygen and hydrogen production [4]. PEC water splitting has been considered as the most attractive method over other hydrogen production approaches. As schematically shown in Fig. 2, when a TiO₂ anode is irradiated by light with energy larger than its band gap, electrons and holes are generated in the conduction and valence bands, respectively. As a result, water is oxidized by photogenerated holes on the TiO₂ anode to produce oxygen, while photogenerated electrons transfer to the Pt counter electrode and participate in hydrogen production. In the PEC process, oxygen production on photoanodes, involved in a 4-electron reaction, is kinetically limited for water splitting. Thus, much research effort has been focused on the design of nanostructured photoanodes for oxygen production via PEC water splitting.

TiO₂ represents one of the most important semiconductor materials for PEC water splitting. Due to its large band gap of about 3.2 eV, TiO₂ cannot absorb visible and infrared light for solar water splitting. Thus, doping of either metal or non-metal ions has been widely adopted to narrow the band gap of TiO₂ by introducing acceptor or donor levels in the forbidden band, making TiO₂ sensitive to visible light [5,6]. For example, a C-doped TiO₂ nanocrystalline film, prepared by controlled combustion of Ti metal in a natural gas flame, exhibited a high water-splitting performance with a total conversion efficiency of 11% and a maximum photoconversion efficiency of 8.35%. This was mainly due to its enhanced visible light absorption. The morphology of TiO₂ anodes will also affect the PEC water splitting performance, by varying the charge transfer ability. Grimes and co-workers prepared and examined the use of TiO₂ nanotube arrays for PEC water splitting, which greatly benefits from the nanotubular architecture that gave rise to superior electron lifetimes and, hence, more efficient charge separation. A high photoconversion efficiency of 16.5% under UV light illumination could be obtained with 24 mm-long nanotubes electrochemically fabricated in an ethylene glycol based electrolyte.

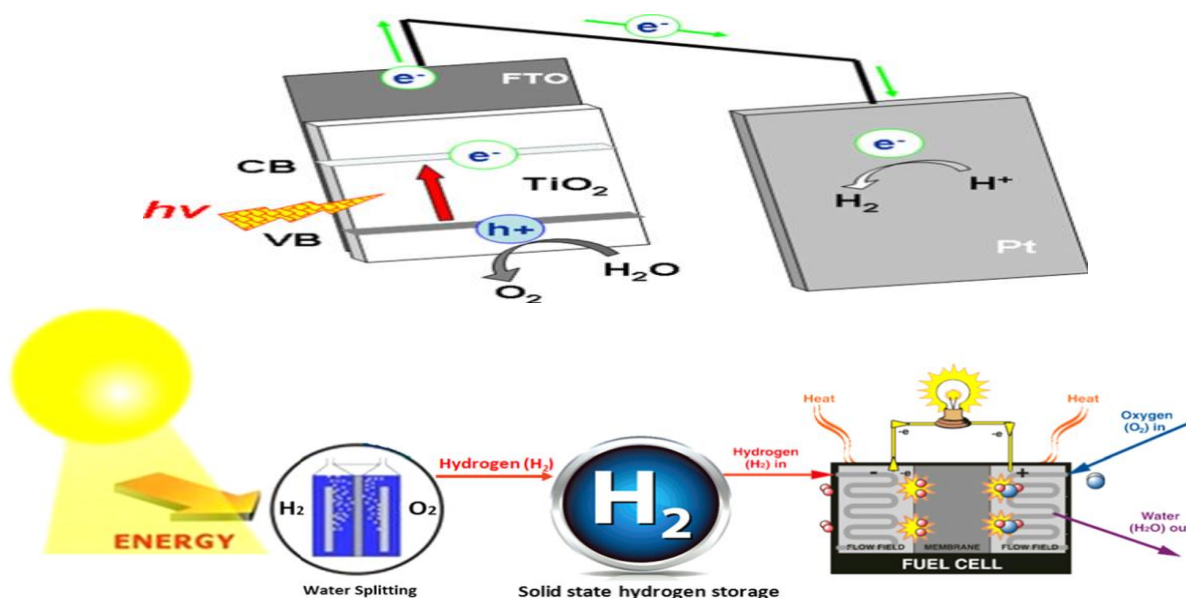

A scheme of renewable energy (e.g., solar energy and hydrogen) based economy based on some selected technologies of renewable energy conversion and utilization.

2-Nano-photocatalysts for hydrogen production

By looking into the basic mechanism and process of photocatalytic water splitting, one could find that efficient photocatalysts should have (1) suitable band gaps and band structures to absorb abundant solar light to drive hydrogen- and oxygen-evolution half-reactions; (2) good charge transfer ability for electrons and holes moving to the semiconductor/electrolyte interface with retarded charge recombination; and (3) high surface catalytic reactivity for half-reactions. In the past decades, numerous efforts have been dedicated to meet these critical requirements of photocatalysts designed for high efficiency hydrogen production from water [5,37–41]. In this section, research progress in our group on the design of nano-photocatalysts for hydrogen production was introduced, showing our great efforts and professional ideas to advance this technology, applicable for high-efficiency and low-cost solar fuel production in the near future.

As discussed in the previous section, TiO₂, as the most studied wide band gap photocatalyst, has been extensively doped with ions to narrow its band gap for efficient visible light photocatalytic hydrogen production [6]. However, the doping-created energy levels could act as recombination centers for photoinduced charges, which would seriously limit the photocatalytic activity of doped TiO₂.

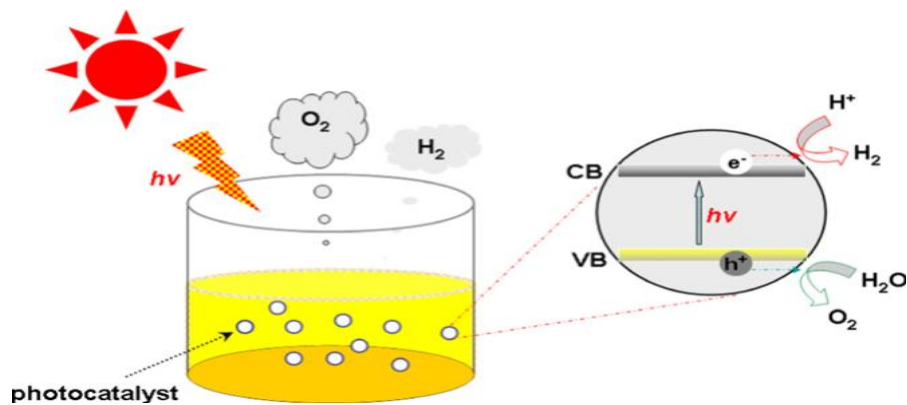

Illustrated scheme of photocatalytic water splitting

CO₂ Capture or Separation Technologies

Direct air capture, apart from its physical occurrence in vegetation and trees (the REDD+ programme from the United Nations), was and is until now the least investigated, but might carry a huge potential, although the American Physical Society's most optimistic calculations estimate the cost of direct air capture at \$600/ton of carbon dioxide removed. Natural CO₂ capture and reuse is seen daily in the function of trees and vegetation. The efficiency of these natural systems are small, but forests also provide other advantages to nature and humankind such as biodiversity, food and fiber, novel drugs, and so on and they are already playing an important role in reducing the overall CO₂ concentrations as only half of the emitted carbon dioxide ends up in the air. The rest is captured in soil, water, and trees and vegetation,.

CO₂ can be captured using different technologies and at different stages of the combustion/power generation process and also directly from air: postcombustion, precombustion, oxyfuel combustion, chemical looping combustion, cryogenic separation, and direct air capture technologies (Figure).

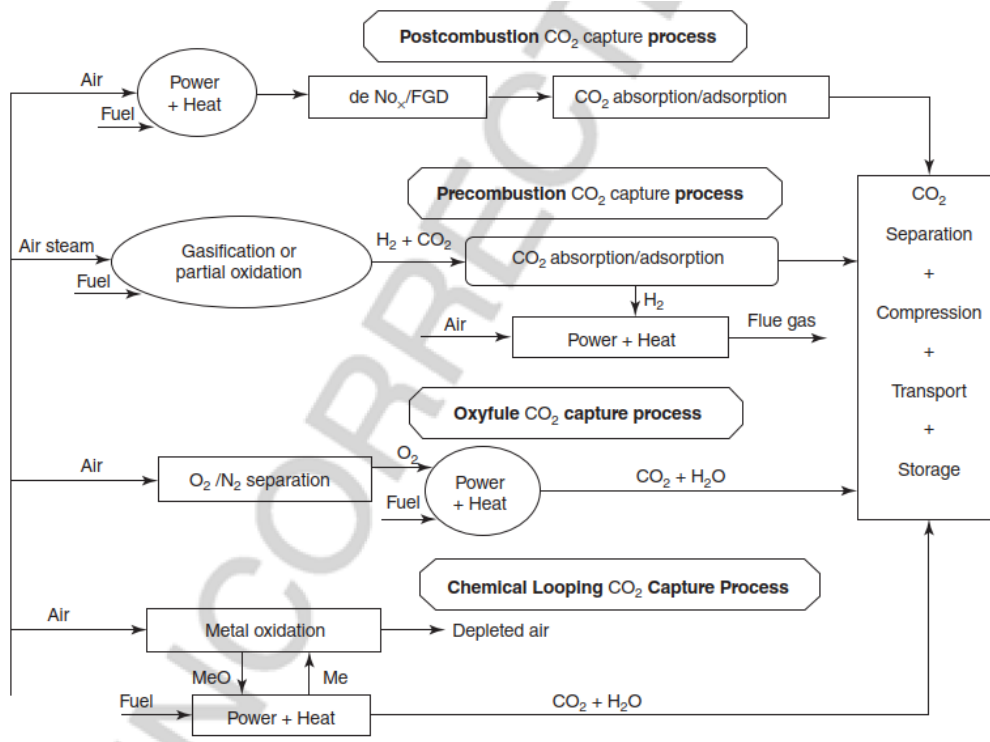

Overview of CO₂ capture technologies

There exist different CO₂ separation technologies that can be applied to isolate the CO₂ from the flue/fuel gas stream prior to transportation. Advanced technologies, such as wet scrubber, dry regenerable sorbents, membranes, cryogenics, pressure and temperature swing adsorption, and other concepts have been developed.

1-silica-supported poly(ethyleneimine) (PEI) materials are demonstrated to be promising adsorbents for CO₂ capture from ambient air. The materials have an enhanced thermal stability with extremely high CO₂ adsorption capacities under simulating ambient air conditions (400 ppm CO₂ in inert gas), exceeding 2 mol CO₂=kg sorbent, as well as enhanced adsorption kinetics compared to conventional class 1 sorbents.

2-Metal-Organic Frameworks (MOF): Zeolites, microporous aluminosilicate materials, are among the most commercially available adsorbents studied for CO₂ capture [32]. Their pores have the ability to selectively sort molecules based on a size exclusion process [33]. From numerous studies, it is apparent that zeolites are a more effective adsorbent at lower temperatures and higher pressures [34]. It is

expected that the disadvantages associated with zeolites prevent them from becoming a major contributor.