



الكيمياء الحياتية
قسم تقنيات البصريات
المرحلة الأولى
أ.م.د. احمد موسى خلف

*College of
Health and
Medical
Techniques/*
AL-DOUR

Department
**OF OPTICS
TECHNIQUES**

BIOCHEMISTRY

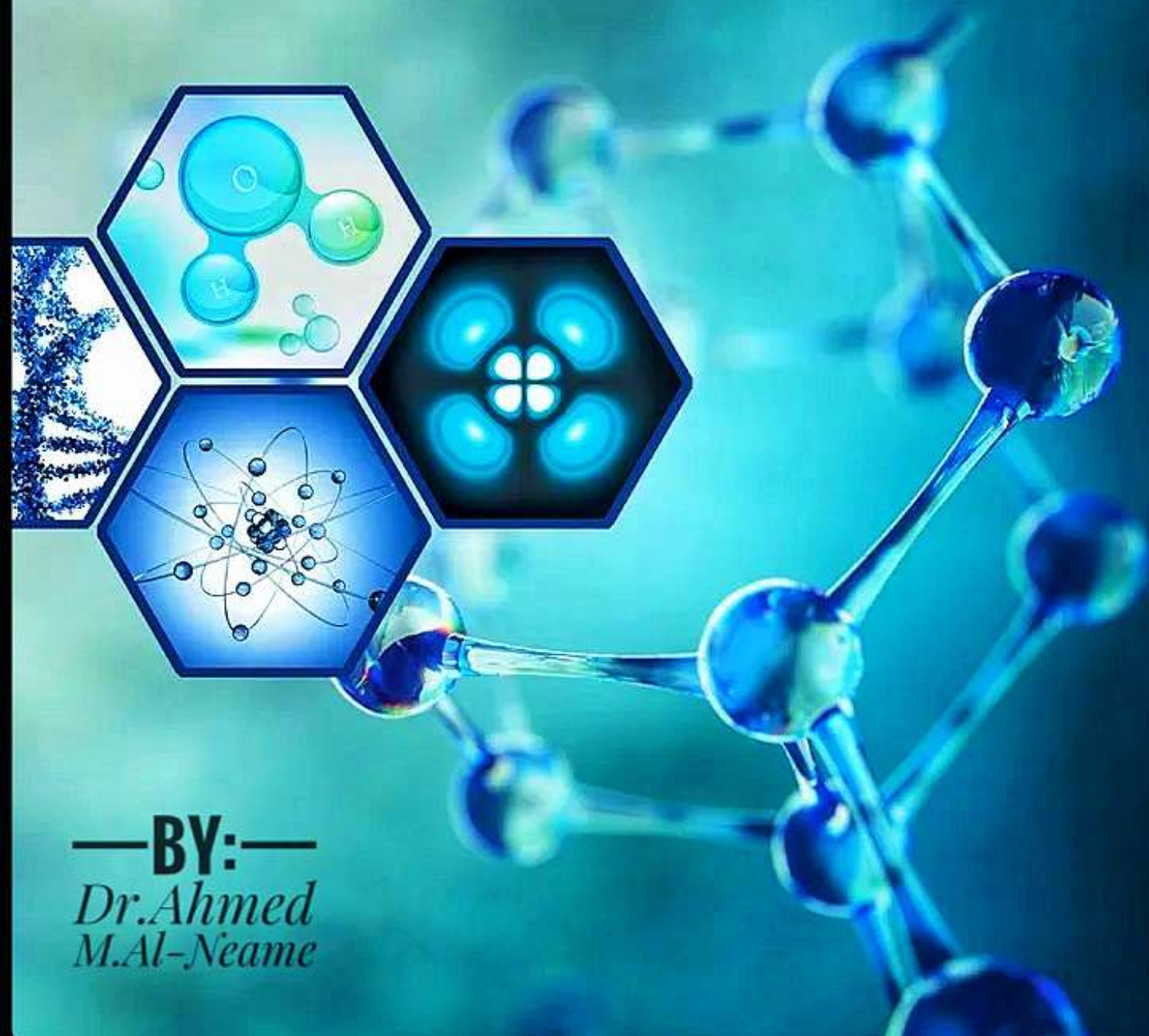

—BY:—
*Dr. Ahmed
M. Al-Neame*



Carbohydrate

Carbohydrate, class of naturally occurring compounds and derivatives formed from them. In the early part of the 19th century, substances such as wood, starch, and linen were found to be composed mainly of molecules containing atoms of carbon (C), hydrogen (H), and oxygen (O) and to have the general formula $C_6H_{12}O_6$; other organic molecules with similar formulas were found to have a similar ratio of hydrogen to oxygen. The general formula $C_x(H_2O)_y$ is commonly used to represent many carbohydrates, which means “watered carbon.”

starch

Carbohydrates are probably the most abundant and widespread organic substances in nature, and they are essential constituents of all living things. Carbohydrates are formed by green plants from carbon dioxide and water during the process of photosynthesis. Carbohydrates serve as energy sources and as essential structural components in organisms; in addition, part of the structure of nucleic acids, which contain genetic information, consists of carbohydrate.

Biological significance

The importance of carbohydrates to living things can hardly be overemphasized. The energy stores of most animals and plants are both carbohydrate and lipid in nature; carbohydrates are generally available as an immediate energy source, whereas lipids act as a long-term energy resource and tend to be utilized at a slower rate. Glucose, the prevalent uncombined, or free, sugar circulating in the blood of higher animals, is essential to cell function. The proper regulation of glucose metabolism is of paramount importance to survival.

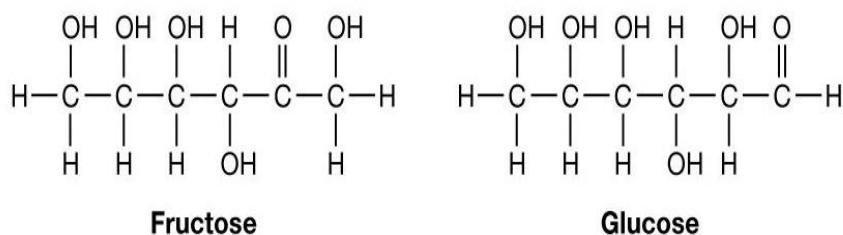



Classes of carbohydrates

Monosaccharides

The most common naturally occurring monosaccharides are D-glucose, D-mannose, D-fructose, and D-galactose among the hexoses and D-xylose and L-arabinose among the pentoses. In a special sense, D-ribose and 2-deoxy-D-ribose are ubiquitous because they form the carbohydrate component of ribonucleic acid (RNA) and deoxyribonucleic acid (DNA), respectively; these sugars are present in all cells as components of nucleic acids.

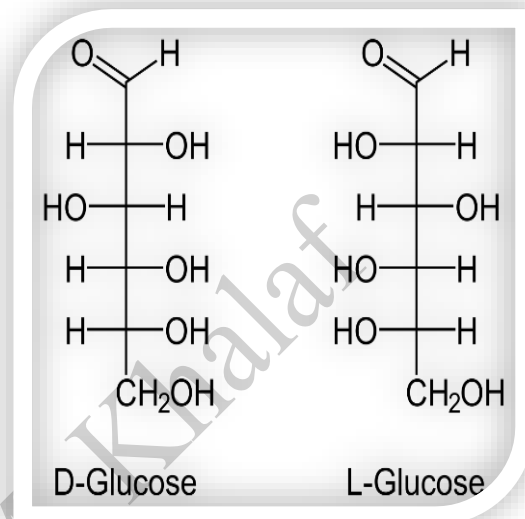

Monosaccharides (from Greek *monos*: single, *sacchar*: sugar), also called **simple sugars**, are the simplest forms of sugar and the most basic units (monomers) from which all carbohydrates are built. Simply, this is the structural unit of carbohydrates.

They are usually colorless, water-soluble, and crystalline shaped organic solids. Contrary to their name (sugars), only some monosaccharides have a sweet taste. Most monosaccharides have the formula $(\text{CH}_2\text{O})_x$ (though not all molecules with this formula are monosaccharides).

Examples of monosaccharides/include glucose (dextrose), fructose (levulose), and galactose.

Monosaccharides are the building blocks of disaccharides (such as sucrose and lactose) and polysaccharides (such as cellulose and starch). The table sugar used in everyday vernacular is itself a disaccharide sucrose comprising one molecule of each of the two monosaccharides d-glucose and d-fructose.

Each carbon atom that supports a hydroxyl group is chiral, except those at the end of the chain. This gives rise to a number of isomeric forms, all with the same chemical formula. For instance, galactose and glucose are both aldohexoses, but have different physical structures and chemical properties.



The monosaccharide glucose plays a pivotal role in metabolism, where the chemical energy is extracted through glycolysis and the citric acid cycle to provide energy to living organisms.

A Disaccharide (also called a double sugar or biose) is the sugar formed when two monosaccharides are joined by glycosidic linkage. Like monosaccharides, disaccharides are simple sugars soluble in water. Three common examples are sucrose, lactose, and maltose.

Disaccharides are one of the four chemical groupings of carbohydrates (monosaccharides, disaccharides, oligosaccharides, and polysaccharides). The most common types of disaccharides—sucrose, lactose, and maltose—have 12 carbon atoms, with the general formula $C_{12}H_{22}O_{11}$. The differences in these disaccharides are due to atomic arrangements within the molecule.

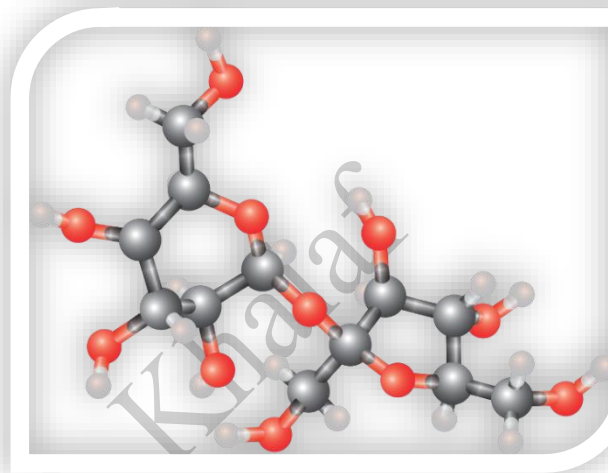

The joining of monosaccharides into a double sugar happens by a condensation reaction, which involves the elimination of a water molecule from the functional groups only. Breaking apart a double sugar into its two monosaccharides is accomplished by hydrolysis with the help of a type of enzyme called a disaccharidase. As building the larger sugar ejects a water molecule, breaking it down consumes a water molecule. These reactions are vital in metabolism. Each disaccharide is broken down with the help of a corresponding disaccharidase (sucrase, lactase, and maltase).

Polysaccharides (/ˌpɒliˈsækərəɪd/), or polycarbohydrates, are the most abundant carbohydrates found in food. They are long-chain polymeric carbohydrates composed of monosaccharide units bound together by glycosidic linkages. This carbohydrate can react with water (hydrolysis) using amylase enzymes as catalyst, which produces constituent sugars (monosaccharides, or oligosaccharides). They range in structure from linear to highly branched. Examples include storage polysaccharides such as starch, glycogen and galactogen and structural polysaccharides such as cellulose and chitin.



Polysaccharides are often quite heterogeneous, containing slight modifications of the repeating unit. Depending on the structure, these macromolecules can have distinct properties from their monosaccharide building blocks. They may be amorphous or even insoluble in water.

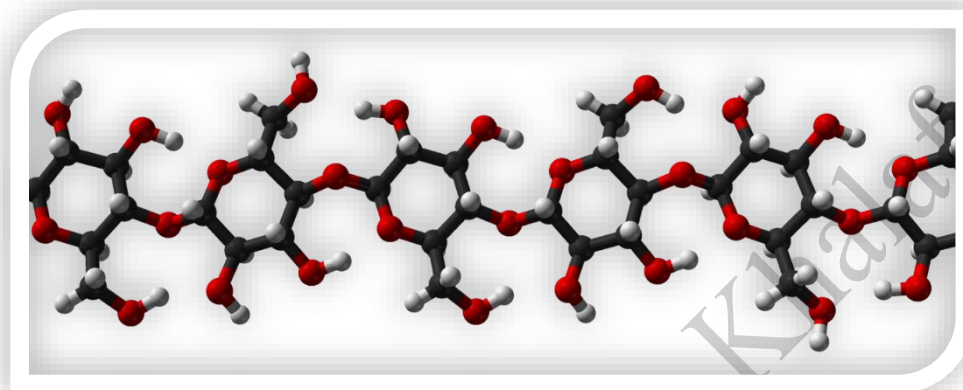

When all the monosaccharides in a polysaccharide are the same type, the polysaccharide is called a homopolysaccharide or homoglycan, but when more than one type of monosaccharide is present, they are called heteropolysaccharides or heteroglycans.

Natural saccharides are generally composed of simple carbohydrates called monosaccharides with general formula $(\text{CH}_2\text{O})_n$ where n is three or more. Examples of monosaccharides are glucose, fructose, and glyceraldehyde. Polysaccharides, meanwhile, have a general formula of $\text{C}_x(\text{H}_2\text{O})_y$ where x and y are usually large numbers between 200 and 2500. When the repeating units in the polymer backbone are six-carbon monosaccharides, as is often the case, the general formula simplifies to $(\text{C}_6\text{H}_{10}\text{O}_5)_n$, where typically $40 \leq n \leq 3000$.

As a rule of thumb, polysaccharides contain more than ten monosaccharide units, whereas oligosaccharides contain three to ten monosaccharide units, but the precise cutoff varies somewhat according to the convention. Polysaccharides are an important class of biological polymers. Their function in living

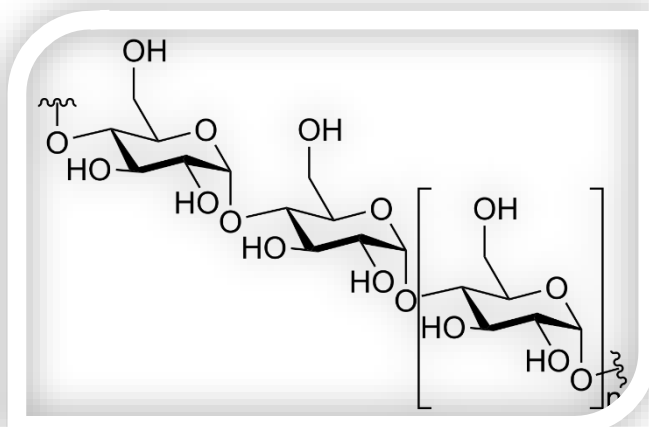



organisms is usually either structure- or storage-related. Starch (a polymer of glucose) is used as a storage polysaccharide in plants, being found in the form of both amylose and the branched amylopectin. In animals, the structurally similar glucose polymer is the more densely branched glycogen, sometimes called "animal starch". Glycogen's properties allow it to be metabolized more quickly, which suits the active lives of moving animals. In bacteria, they play an important role in bacterial multicellularity.

Hydrolysis of Carbohydrates

- Carbohydrates are also known as sugars or saccharides.
- Hydrolysis is a reaction with water.

Hydrolysis reactions are also referred to as hydrolytic reactions.

- Acid hydrolysis is a reaction with acidified water (acidic conditions).
- Disaccharides can be hydrolysed under acidic conditions.

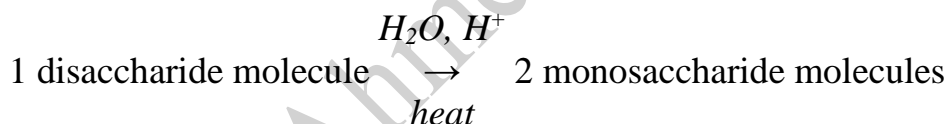

- Polysaccharides can be hydrolysed under acidic conditions.

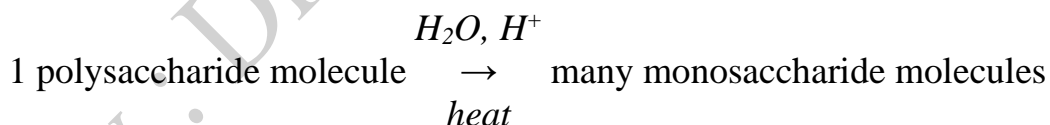

- Acid hydrolysis of disaccharides and polysaccharides produces monosaccharides by breaking the glycosidic links (ether bonds) between monomer units in the structure of the molecule.
- Human beings can digest disaccharides and the polysaccharide known as starch by hydrolysis using enzymes in enzyme catalysed hydrolysis reactions.

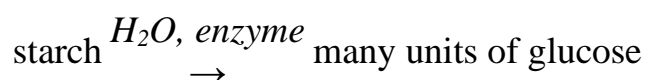

- The ability of humans to digest the disaccharide lactose, "milk sugar", decreases as we develop due to a decline in the activity of the enzyme lactase.

Lactose intolerance results from low levels of the enzyme lactase and hence incomplete hydrolysis of lactose.

- Human beings cannot digest the polysaccharide known as cellulose because we lack an appropriate enzyme to hydrolyse cellulose.

Hydrolysis of Disaccharides

- Sucrose, table sugar, is an example of a disaccharide. It is produced by the condensation reaction between the monosaccharides glucose and fructose as shown below:

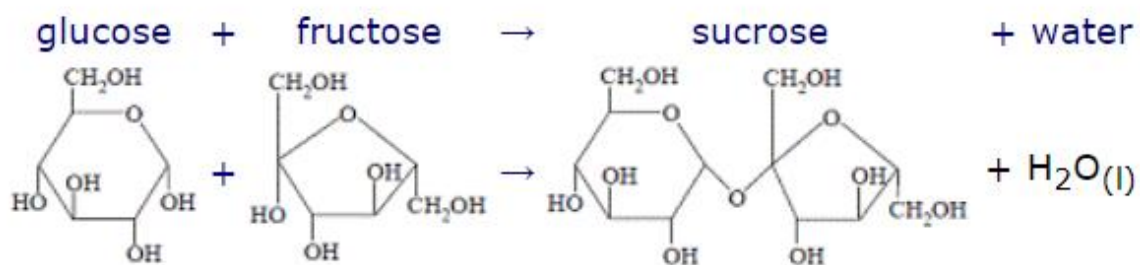

Peptide

Peptides are short chains of amino acids linked by peptide bonds. A **polypeptide** is a longer, continuous, unbranched peptide chain. **Polypeptides** that have a molecular mass of 10,000 Da or more are called proteins. Chains of fewer than twenty amino acids are called **Oligopeptides**, and include **dipeptides**, **tripeptides**, and **tetrapeptides**.

Peptides fall under the broad chemical classes of biological polymers and oligomers, alongside nucleic acids, oligosaccharides, polysaccharides, and others.

Proteins consist of one or more polypeptides arranged in a biologically functional way, often bound to ligands such as coenzymes and cofactors, to another protein or other macromolecule such as DNA or RNA, or to complex macromolecular assemblies.

Amino acids that have been incorporated into peptides are termed residues. A water molecule is released during formation of each amide bond. All peptides except cyclic peptides have an **N-terminal (amine group)** and **C-terminal (carboxyl group)** residue at the end of the peptide .

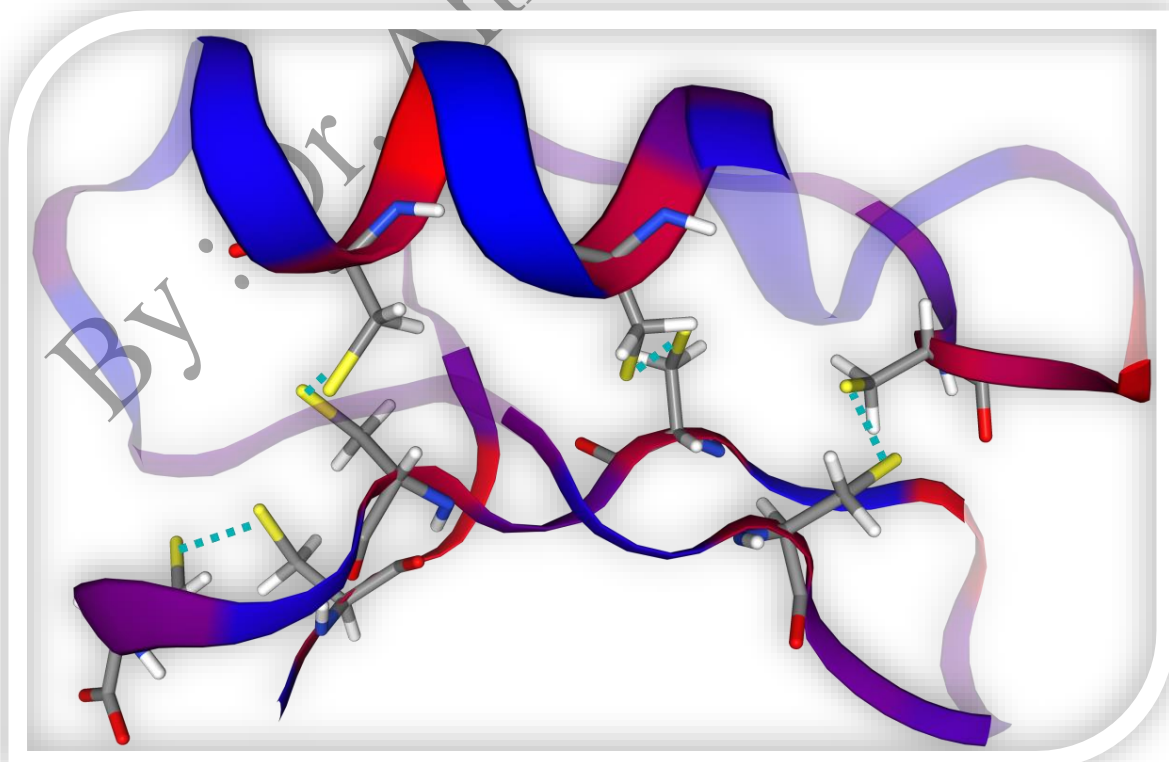

Structure and Classification of Peptides

Peptides are formed by linking two or more amino acids through an amide linkage, called a peptide bond. The formation of peptide bonds occurs by the removal of a hydroxyl group (-OH) from one alpha-amino group and hydrogen (-H) atom from another alpha-amino group, forming a water molecule (H₂O).

Peptides are sub-categorized into two groups based on the number of amino acids present in their structures: **Oligopeptides** and **Polypeptides**.

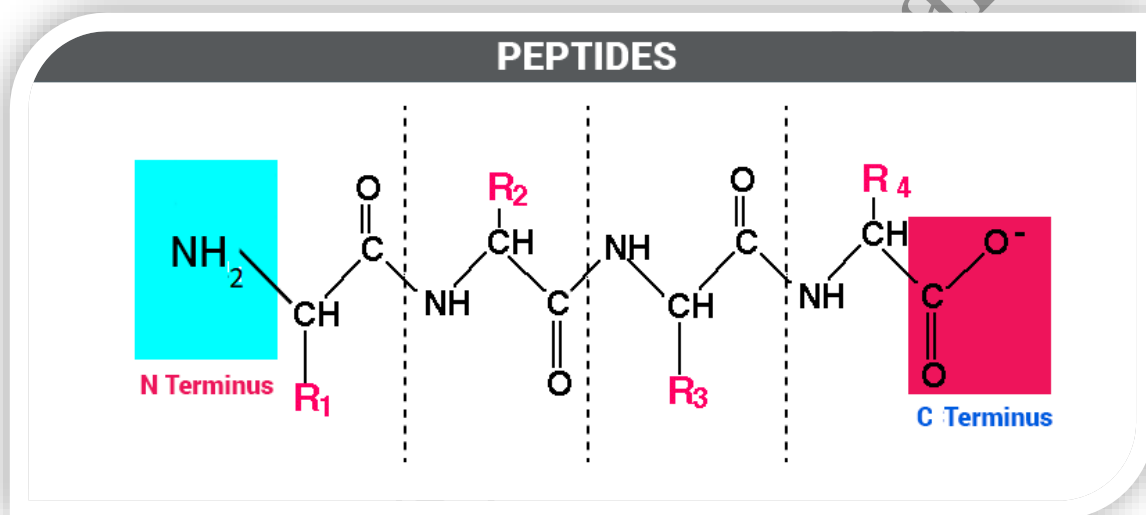

➤ Oligopeptides

When two or more (but less than 20) amino acids are linked together with the loss of a water molecule, they are called oligopeptides. It also includes dipeptides, tripeptides, tetrapeptides, and pentapeptides.

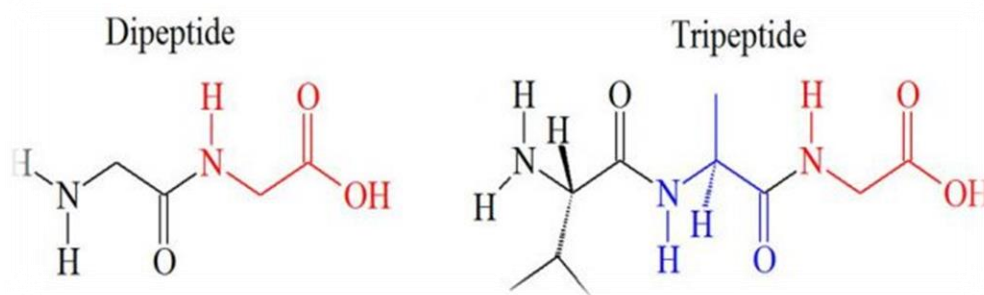



➤ Polypeptides

When 20 or more amino acids are linked together through covalent peptide bonds, they are called polypeptides. One or more polypeptides are involved in the formation of proteins. They have two terminals present in their structure: N-terminal containing an amino group and C-terminal containing a carboxyl group. Some examples of polypeptides include insulin and growth hormones.

Classes of Peptides and Their Biological Significance

Peptides, based on their functional properties, are categorized into many small groups. Here's a list of the most commonly studied classes of peptides in organisms

1- Antimicrobial Peptides

Antimicrobial peptides, also known as host defense peptides, are a class of peptides that play a role in the innate immune response of all organisms.

2- Bacterial Peptides

As the name suggests, bacterial peptides are fragments of proteins produced by bacteria. They include flagellar peptides, lipoproteins, enterotoxins, and several enzymes.

3- Neuropeptides

These are small proteins synthesized by neurons to act on receptors and modulate synaptic transmission.

The neuropeptides are synthesized by large, inactive precursor proteins, called **pre-propeptides**.

4- Anticancer Peptides

Anticancer peptides (ACPs) are small peptides with a short amino acid sequence that are selective and toxic to cancer cells. The predominant amino acids in anticancer peptides include **glycine**, **lysine**, and **leucine**.



The anticancer peptides are a highly preferred choice among all the other available anticancer therapeutics due to their high selectivity, high penetration, and easy modifications.

The peptides destroy cancer cells via apoptosis and necrosis by lysing or forming pores in the membranes of cancerous cells.

These types of peptides, depending on their structure, mode of action, selectivity, and efficacy to specific cancer cells, are divided into three categories:

- **Molecularly targeted peptides:** They directly act on cancer cells via cytotoxic, anti-proliferative, and apoptotic activities.
- **'Guiding missile' peptides or binding peptides:** They are drug binding peptides that deliver drugs to the targeted cancer cells.
- **Cell-stimulating peptides:** They indirectly kill cancer cells by stimulating other cells via immunomodulatory activities and hormone receptors.

5- Cardiovascular Peptides

Cardiovascular peptides have a role in physiological and pathological conditions in the cardiovascular system.[10] They are implicated in controlling vascular tone, blood pressure, congestive heart failure, atherosclerosis, coronary artery diseases, and pulmonary and systemic hypertension.

Role of protein in the eye (cornea, lens, retina)

Review page (20-21)

Lipids

Lipids are a broad group of organic compounds which include fats, waxes, sterols, fat-soluble vitamins (such as vitamins A, D, E and K), monoglycerides, diglycerides, phospholipids, and others. The functions of lipids include storing energy, signaling, and acting as structural components of cell membranes. Lipids have applications in the cosmetic and food industries, and in nanotechnology.

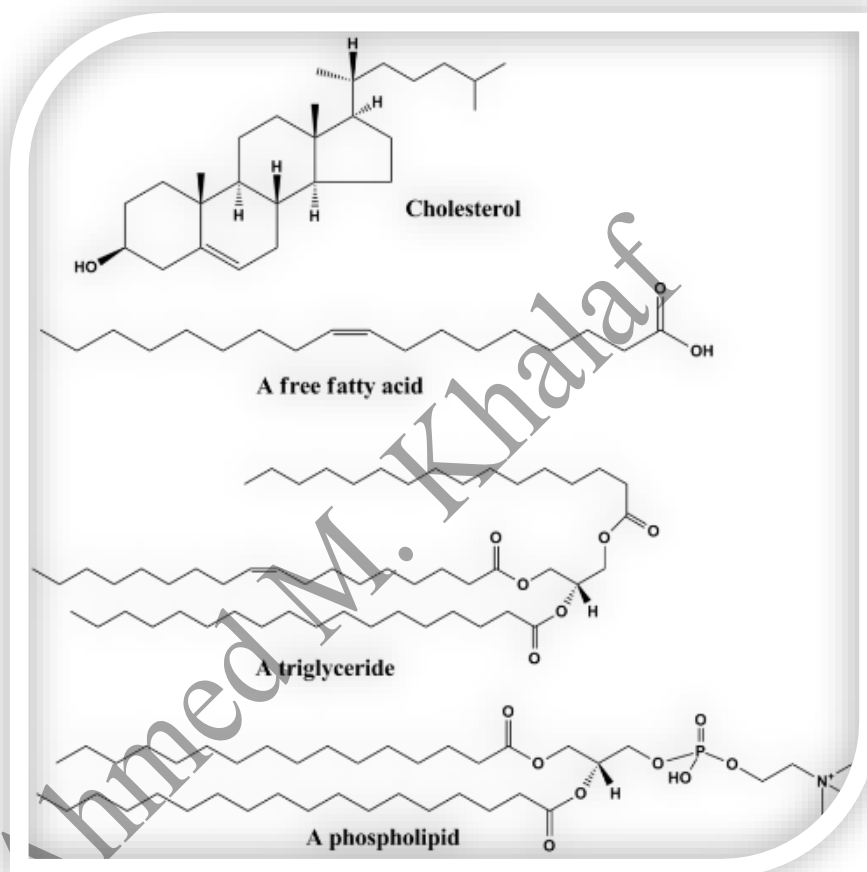

Although the term "**lipid**" is sometimes used as a synonym for **fats**, fats are a subgroup of lipids called triglycerides. **Lipids** also encompass molecules such as fatty acids and their derivatives (including tri-, di-, monoglycerides, and phospholipids), as well as other sterol-containing metabolites such as cholesterol. Although humans and other mammals use various biosynthetic pathways both to break down and to synthesize lipids, some essential lipids cannot be made this way and must be obtained from the diet.

Properties of Lipid

Lipids, a family of organic compounds, are composed of fats and oils. These high-energy molecules play various roles within the human body. Here are some key characteristics of Lipids.

1. Lipids are greasy or oily nonpolar molecules, stored in the body's adipose tissue.
2. Lipids are a heterogeneous group of compounds, primarily composed of hydrocarbon chains.
3. Lipids are energy-rich organic molecules, providing energy for various life processes.
4. Lipids are a class of compounds characterized by their solubility in nonpolar solvents and insolubility in water.
5. Lipids play a significant role in biological systems as they form a mechanical barrier dividing a cell from the external environment, known as the cell membrane.

Lipids, as organic compounds, are nonpolar molecules. They dissolve only in nonpolar solvents and are water-insoluble due to the polar nature of water. In our bodies, lipids can be synthesized in the liver and are commonly found in food items such as oil, butter, whole milk, cheese, fried foods, and certain red meats.

The Structure of Lipids

Lipids are polymers of fatty acids containing a long, non-polar hydrocarbon chain with a small polar region containing oxygen. The lipid structure is illustrated in the diagram:

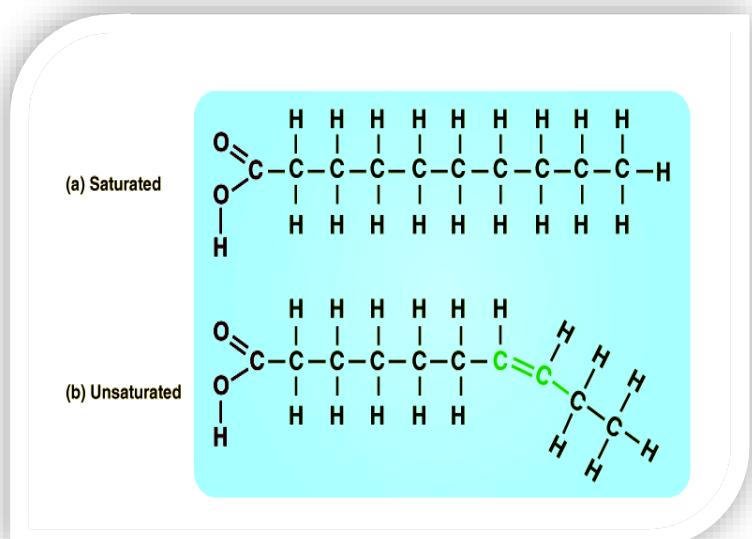
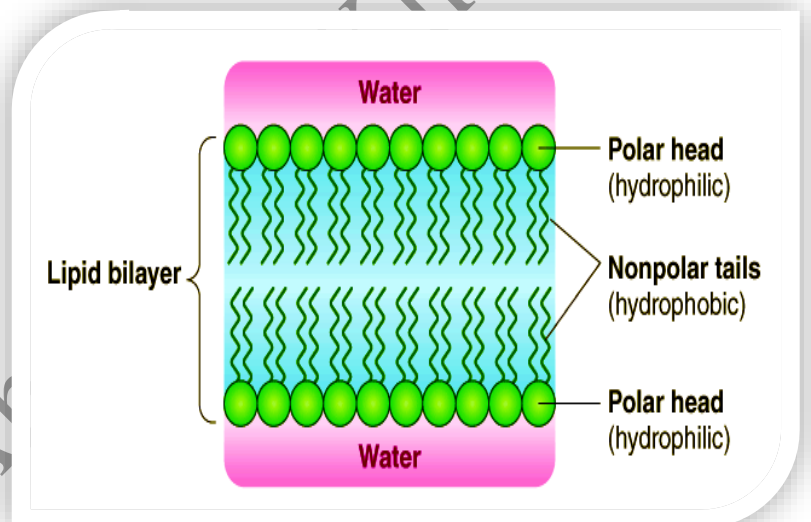



Lipid Classification

Lipids can be divided into two main categories:

- Nonsaponifiable lipids
- Saponifiable lipids

Nonsaponifiable Lipids

A nonsaponifiable lipid cannot be broken down into smaller molecules through hydrolysis. Examples of nonsaponifiable lipids include cholesterol, prostaglandins, and others.

Saponifiable Lipids

A saponifiable lipid contains one or more ester groups, enabling it to undergo hydrolysis in the presence of a base, acid, or enzymes, including waxes, triglycerides, sphingolipids, and phospholipids.

Furthermore, these categories can be divided into non-polar and polar lipids.

Nonpolar lipids, like triglycerides, are used as fuel and to store energy.

Polar lipids, which can form a barrier with an external water environment, are used in membranes. Polar lipids include sphingolipids and glycerophospholipids.

Different Types of Lipids

Within these two major lipid classes, there are numerous specific types of lipids that are essential to life, including fatty acids, triglycerides, glycerophospholipids, sphingolipids, and steroids. These are broadly classified as simple lipids and complex lipids.

Simple Lipids

Simple lipids are esters of fatty acids with various alcohols.

1. **Fats:** Fats are esters of fatty acids with glycerol. Oils are fats in liquid form.



2. **Waxes** : Waxes are esters of fatty acids with higher molecular weight monohydric alcohols.

Complex Lipids

Complex lipids are esters of fatty acids containing groups in addition to alcohol and fatty acid.

1. **Phospholipids** : These are lipids containing, in addition to fatty acids and alcohol, a phosphate group. They often have nitrogen-containing bases and other substituents, e.g., in glycerophospholipids the alcohol is glycerol, and in sphingophospholipids the alcohol is sphingosine.
2. **Glycolipids (glycosphingolipids)** : Lipids containing a fatty acid, sphingosine, and carbohydrate.
3. **Other complex lipids** : Lipids such as sulfolipids and amino lipids. Lipoproteins may also be placed in this category.

Precursor and Derived Lipids

These include fatty acids, glycerol, steroids, other alcohols, fatty aldehydes, and ketone bodies, hydrocarbons, lipid-soluble vitamins, and hormones. Because they are uncharged, acylglycerols (glycerides), cholesterol, and cholesteryl esters are termed neutral lipids. These compounds are produced by the hydrolysis of simple and complex lipids.

Fatty Acids

Fatty acids are carboxylic acids (or organic acid), usually with long aliphatic tails (long chains), either unsaturated or saturated.

- **Saturated fatty acids**

Saturated fatty acids lack carbon-carbon double bonds. These fatty acids have higher melting points than unsaturated acids of the same size due to their ability to pack their molecules together, resulting in a straight rod-like shape.



○ Unsaturated fatty acids

An unsaturated fatty acid has more than one double bond.

“Often, naturally occurring fatty acids possess an even number of carbon atoms and are unbranched.”

On the other hand, unsaturated fatty acids contain cis-double bond(s) which create a structural kink that prevents them from packing their molecules into a straight rod-like shape.

The Function of Fats

Fats have several crucial roles in our body. Some of the important functions of fats include:

- Fats are necessary for the proper functioning of our body when consumed in the correct amounts.
- Many fat-soluble vitamins need to be associated with fats in order to be effectively absorbed by the body.
- They also provide insulation to the body.
- They are an efficient way to store energy for longer periods.

See summary about Lipids:

<https://www.youtube.com/watch?v=7dmoH5dAvpY>

<https://www.youtube.com/watch?v=Ezp8F7XJHWE>

Carbohydrate Metabolism

Carbohydrates are organic molecules composed of carbon, hydrogen, and oxygen atoms. The family of carbohydrates includes both simple and complex sugars. Glucose and fructose are examples of simple sugars, and starch, glycogen, and cellulose are all examples of complex sugars. The complex sugars are also called polysaccharides and are made of multiple monosaccharide molecules. Polysaccharides serve as energy storage (e.g., starch and glycogen) and as structural components (e.g., chitin in insects and cellulose in plants).

During digestion, carbohydrates are broken down into simple, soluble sugars that can be transported across the intestinal wall into the circulatory system to be transported throughout the body. Carbohydrate digestion begins in the mouth with the action of salivary amylase on starches and ends with monosaccharides being absorbed across the epithelium of the small intestine. Once the absorbed monosaccharides are transported to the tissues, the process of cellular respiration begins (Figure1). This section will focus first on glycolysis, a process where the monosaccharide glucose is oxidized, releasing the energy stored in its bonds to produce ATP.

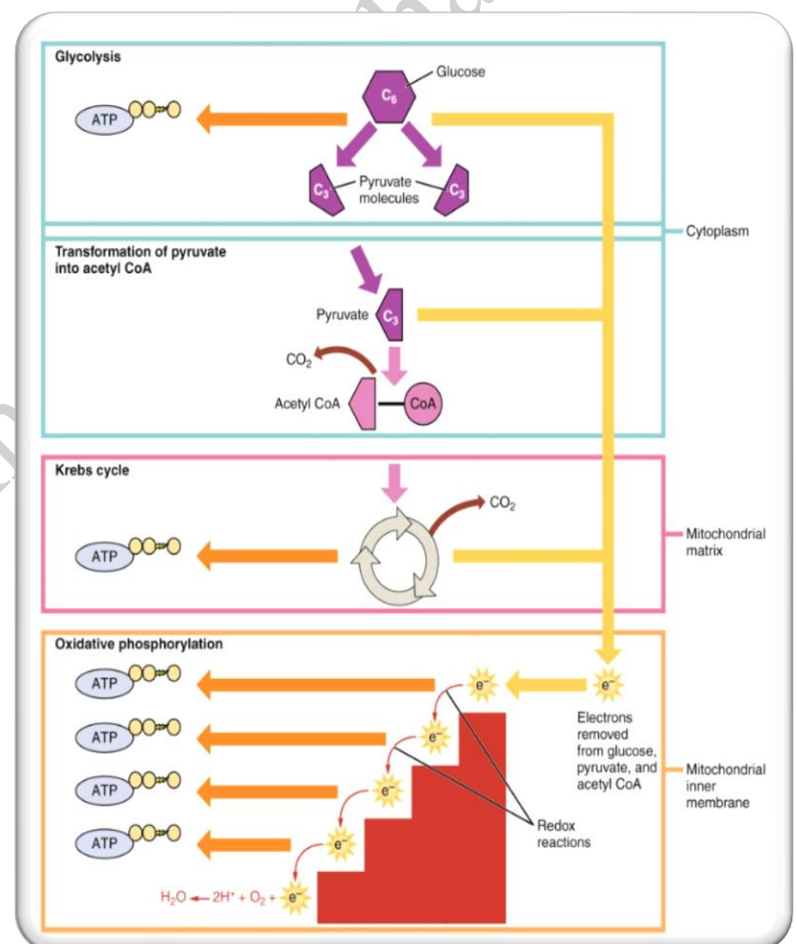

Glycolysis

Glycolysis is the metabolic pathway that converts glucose ($C_6H_{12}O_6$) into pyruvate and, in most organisms, occurs in the liquid part of cells (the cytosol). The free energy released in this process is used to form the high-energy molecules adenosine triphosphate (ATP) and reduced nicotinamide adenine dinucleotide (NADH). Glycolysis is a sequence of ten reactions catalyzed by enzymes.

Summary of the 10 reactions of the glycolysis pathway

The wide occurrence of glycolysis in other species indicates that it is an ancient metabolic pathway. Indeed, the reactions that make up glycolysis and its parallel pathway, the pentose phosphate pathway, can occur in the oxygen-free conditions of the Archean oceans, also in the absence of enzymes, catalyzed by metal ions, meaning this is a plausible prebiotic pathway for abiogenesis.

The most common type of glycolysis is the Embden–Meyerhof–Parnas (EMP) pathway, which was discovered by Gustav Embden, Otto Meyerhof, and Jakub Karol Parnas. Glycolysis also refers to other pathways, such as the Entner–Doudoroff pathway and various heterofermentative and homofermentative pathways. However, the discussion here will be limited to the Embden–Meyerhof–Parnas pathway.

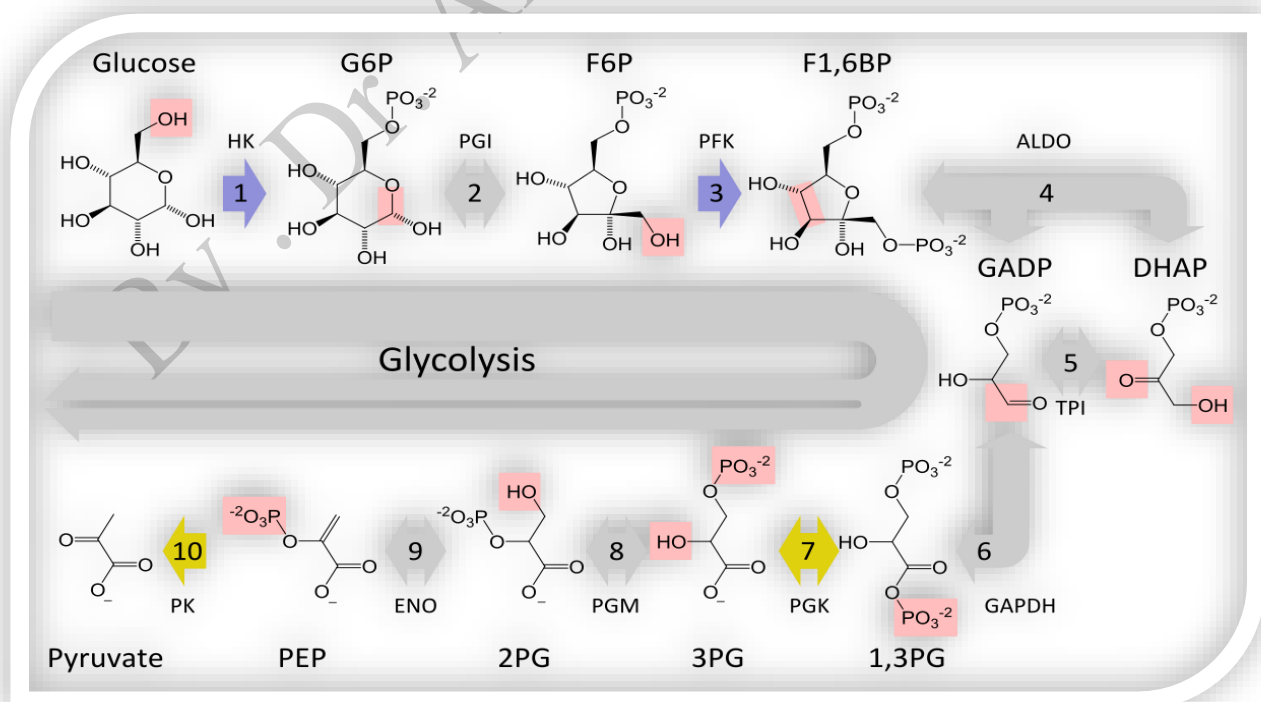



Regulated Enzymes in Glycolysis

The three regulatory enzymes are hexokinase (or glucokinase in the liver), phosphofructokinase, and pyruvate kinase. The flux through the glycolytic pathway is adjusted in response to conditions both inside and outside the cell. The internal factors that regulate glycolysis do so primarily to provide ATP in adequate quantities for the cell's needs. The external factors act primarily on the liver, fat tissue, and muscles, which can remove large quantities of glucose from the blood after meals (thus preventing hyperglycemia by storing the excess glucose as fat or glycogen, depending on the tissue type). The liver is also capable of releasing glucose into the blood between meals, during fasting, and exercise thus preventing hypoglycemia by means of glycogenolysis and gluconeogenesis. These latter reactions coincide with the halting of glycolysis in the liver.

Glycolysis in disease

Diabetes

Cellular uptake of glucose occurs in response to insulin signals, and glucose is subsequently broken down through glycolysis, lowering blood sugar levels. However, the low insulin levels seen in diabetes result in hyperglycemia, where glucose levels in the blood rise and glucose is not properly taken up by cells. Hepatocytes further contribute to this hyperglycemia through gluconeogenesis. Glycolysis in hepatocytes controls hepatic glucose production, and when glucose is overproduced by the liver without having a means of being broken down by the body, hyperglycemia results.

Genetic diseases

Glycolytic mutations are generally rare due to importance of the metabolic pathway; the majority of occurring mutations result in an inability of the cell to respire, and therefore cause the death of the cell at an early stage. However, some mutations (glycogen storage diseases and other inborn errors of carbohydrate metabolism) are seen with one notable example being pyruvate kinase deficiency, leading to chronic hemolytic anemia.



Cancer

Malignant tumor cells perform glycolysis at a rate that is ten times faster than their noncancerous tissue counterparts. During their genesis, limited capillary support often results in hypoxia (decreased O₂ supply) within the tumor cells. Thus, these cells rely on anaerobic metabolic processes such as glycolysis for ATP (adenosine triphosphate). Some tumor cells overexpress specific glycolytic enzymes which result in higher rates of glycolysis. Often these enzymes are Isoenzymes, of traditional glycolysis enzymes, that vary in their susceptibility to traditional feedback inhibition. The increase in glycolytic activity ultimately counteracts the effects of hypoxia by generating sufficient ATP from this anaerobic pathway. This phenomenon was first described in 1930 by Otto Warburg and is referred to as the Warburg effect. The Warburg hypothesis claims that cancer is primarily caused by dysfunctionality in mitochondrial metabolism, rather than because of the uncontrolled growth of cells. A number of theories have been advanced to explain the Warburg effect. One such theory suggests that the increased glycolysis is a normal protective process of the body and that malignant change could be primarily caused by energy metabolism.

Oxygen and Glycolysis in the Retina of the Eye

Hypoxic environments are known to trigger pathological damage in multiple cellular subtypes. Interestingly, the lens is a naturally hypoxic tissue, with glycolysis serving as its main source of energy. Hypoxia is essential for maintaining the long-term transparency of the lens in addition to avoiding nuclear cataracts. Herein, we explore the complex mechanisms by which lens epithelial cells adapt to hypoxic conditions while maintaining their normal growth and metabolic activity. Our data show that the glycolysis pathway is significantly upregulated during human lens epithelial (HLE) cells exposure to hypoxia. The inhibition of glycolysis under hypoxic conditions incited endoplasmic reticulum (ER) stress and reactive oxygen species (ROS) production in HLE cells, leading to cellular apoptosis. After ATP was replenished, the damage to the cells was not completely recovered, and ER stress, ROS production, and cell apoptosis still occurred. These results suggest that glycolysis not only performs energy metabolism in the process of HLE cells adapting to hypoxia, but also helps them continuously resist cell apoptosis caused by ER stress and ROS production. Furthermore, our proteomic atlas provides possible rescue mechanisms for cellular damage caused by hypoxia.



Interactive pathway map

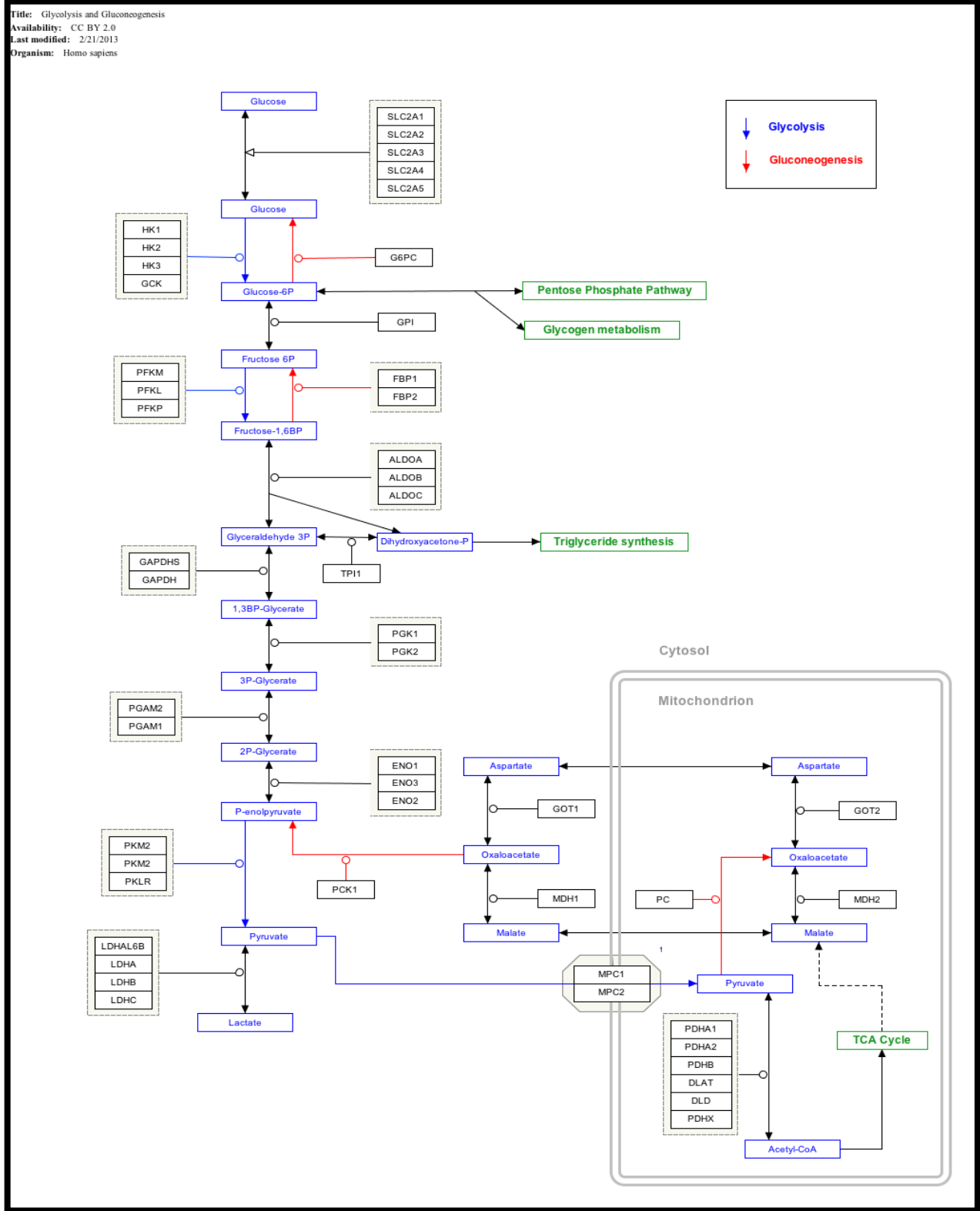

PROTEINS

Proteins are very important molecules that are essential for all living organisms. By dry weight, proteins are the largest unit of cells. Proteins are involved in virtually all cell functions and a different type of protein is devoted to each role, with tasks ranging from general cellular support to cell signaling and locomotion. In total, there are seven types of proteins.

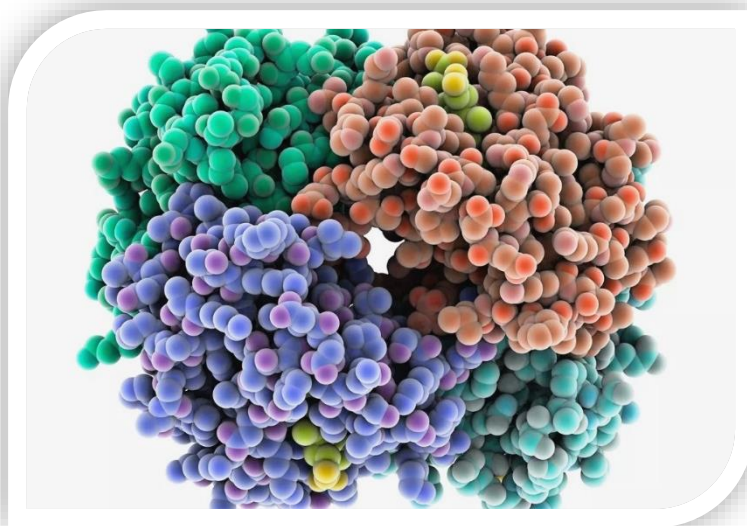

Proteins Information

- **Proteins** are biomolecules composed of amino acids that participate in nearly all cellular activities.
- Occurring in the cytoplasm, **translation** is the process through which proteins are **synthesized**.
- The typical protein is constructed from a single set of **amino acids**. Every protein is specially equipped for its function.
- Any protein in the human body can be created from permutations of only 20 amino acids.
- There are seven types of proteins: **antibodies, contractile proteins, enzymes, hormonal proteins, structural proteins, storage proteins, and transport proteins**.

Proteins are large biomolecules and macromolecules that comprise one or more long chains of amino acid residues. Proteins perform a vast array of functions within organisms, including catalysing metabolic reactions, DNA replication, responding to stimuli, providing structure to cells and organisms, and transporting molecules from one location to another. Proteins differ from one another primarily in their sequence of amino acids, which is dictated by the nucleotide sequence of their genes, and which usually results in protein folding into a specific 3D structure that determines its activity.

Protein Synthesis

Proteins are synthesized in the body through a process called **translation**. Translation occurs in the cytoplasm and involves converting genetic codes into proteins. Genetic codes are assembled during DNA transcription, where DNA is decoded into RNA. Cell structures called ribosomes then help transcribe RNA into polypeptide chains that need to be modified to become functioning proteins.

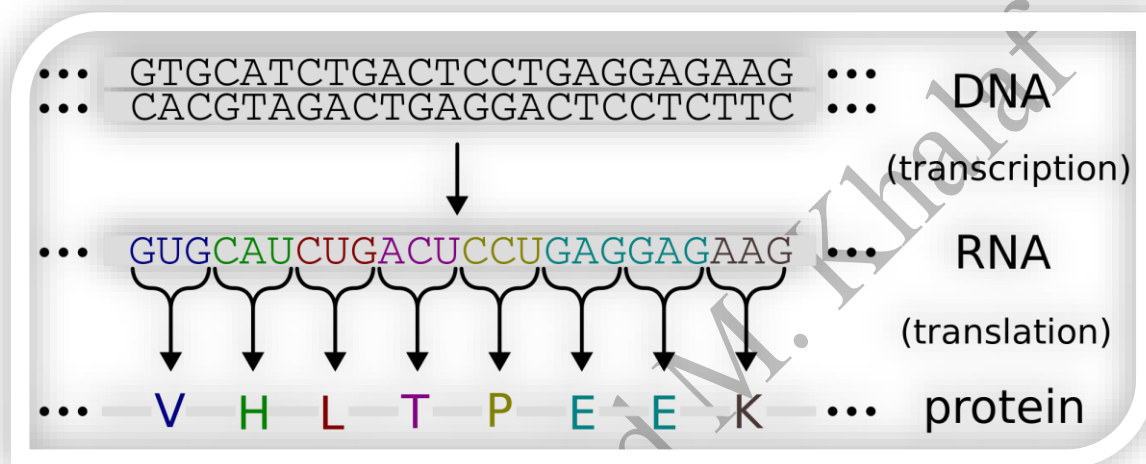

Amino Acids and Polypeptide Chains

Amino acids are the building blocks of all proteins, no matter their function. Proteins are typically a chain of 20 amino acids. The human body can use combinations of these same 20 amino acids to make any protein it needs. Most amino acids follow a structural template in which an alpha carbon is bonded to the following forms:

- A hydrogen atom (H)
- A carboxyl group (-COOH)
- An amino group (-NH₂)
- A "variable" group

Across the different types of amino acids, the "variable" group is most responsible for variation as all of them have hydrogen, carboxyl group, and amino group bonds.

Amino acids are joined through dehydration synthesis until they form peptide bonds. When a number of amino acids are linked together by these bonds, a polypeptide chain is formed. One or more polypeptide chains twisted into a 3-D shape forms a protein.

Protein Structure

The structure of a protein may be **globular** or **fibrous** depending on its particular role (every protein is specialized). Globular proteins are generally compact, soluble, and spherical in shape. Fibrous proteins are typically elongated and insoluble. Globular and fibrous proteins may exhibit one or more types of protein structures.

There are four structural levels of protein: primary, secondary, tertiary, and quaternary. These levels determine the shape and function of a protein and are distinguished from one another by the degree of complexity in a polypeptide chain. The primary level is the most basic and rudimentary while the quaternary level describes sophisticated bonding.

A single protein molecule may contain one or more of these protein structure levels and the structure and intricacy of a protein determine its function. Collagen, for example, has a super-coiled helical shape that is long, stringy, strong, and rope-like—collagen is great for providing support. Hemoglobin, on the other hand, is a globular protein that is folded and compact. Its spherical shape is useful for maneuvering through blood vessels.

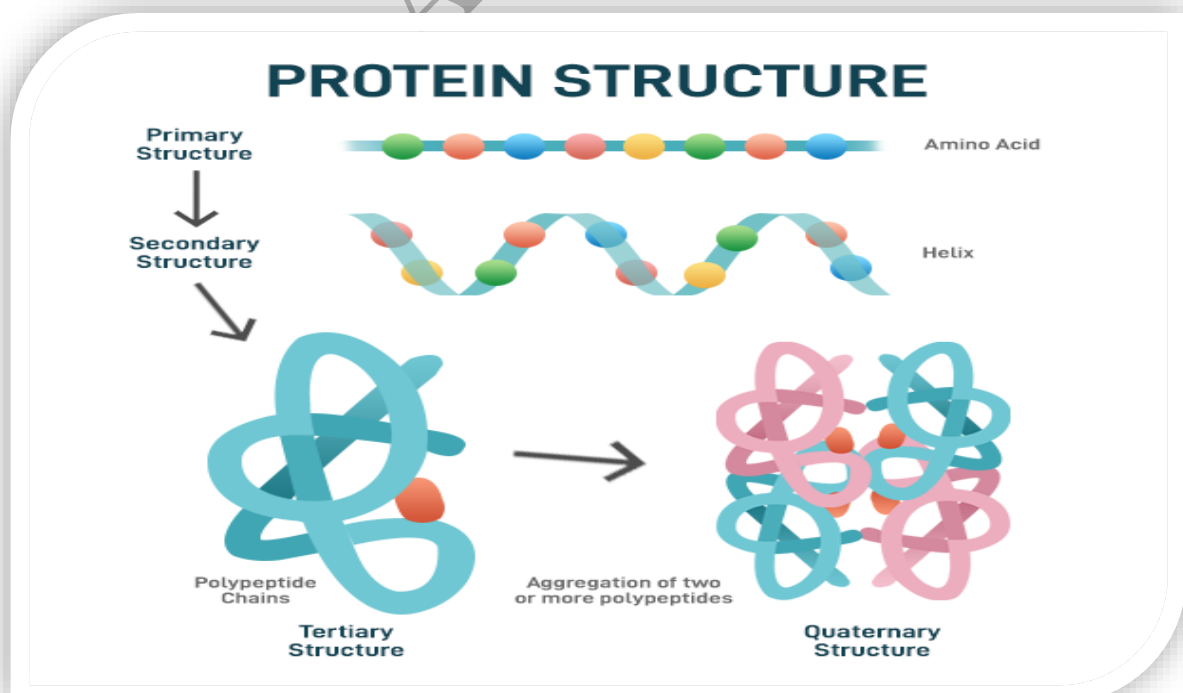

Protein sources (Protein foods)

Some food sources of dietary protein include:

- lean meats – beef, lamb, veal, pork, kangaroo
- poultry – chicken, turkey, duck, emu, goose, bush birds
- fish and seafood – fish, prawns, crab, lobster, mussels, oysters, scallops, clams
- eggs
- dairy products – milk, yoghurt (especially Greek yoghurt), cheese (especially cottage cheese)
- nuts (including nut pastes) and seeds – almonds, pine nuts, walnuts, macadamias, hazelnuts, cashews, pumpkin seeds, sesame seeds, sunflower seeds
- legumes and beans – all beans, lentils, chickpeas, split peas, tofu.

Some grain and cereal-based products are also sources of protein, but are generally not as high in protein as meat and meat-alternative products.

Classification of Proteins

Classification of proteins is done on the basis of the following:

- Shape
- Constitution
- Nature of molecules
- On the basis of shape

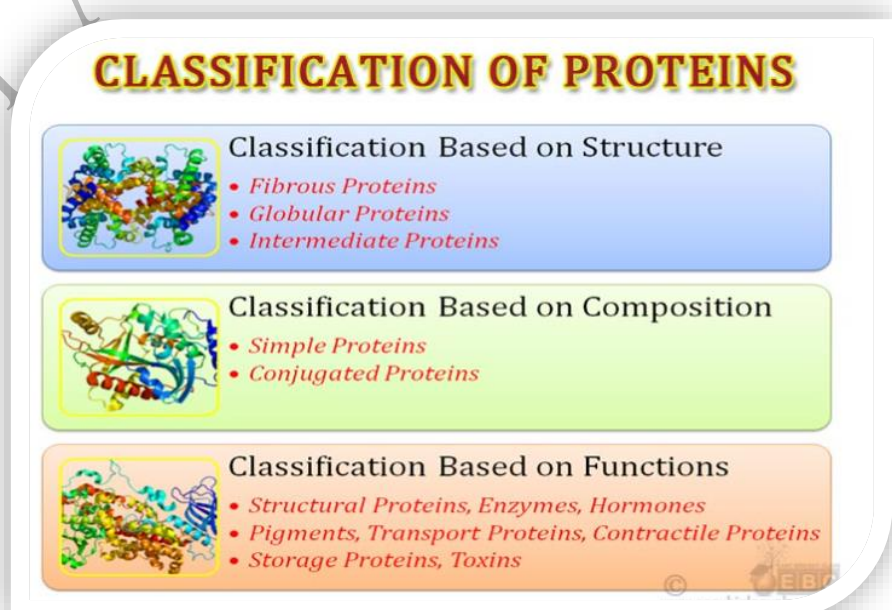



- **Fibrous protein(Scleroprotein):** We can find these proteins in animals and are insoluble in water. Fibrous proteins are resistant to proteolytic enzymes and are coiled and exist in threadlike structures to form fibres. e.g. collagen, actin, and myosin, keratin in hair, claws, feathers, etc.
- **Globular proteins:** These proteins, unlike fibrous proteins are soluble in water. They are made up of polypeptides that are coiled about themselves to form oval or spherical molecules e.g. albumin, insulin, and hormones like oxytocin, etc.

On the basis of Constitution

- **Simple proteins:** These proteins are made up of amino acids only. e.g. albumins, globulins, prolamins, etc.
- **Conjugated proteins:** These are complex proteins that are combined with the characteristic of non-amino acid substance called as a prosthetic group. These are of following types:–
 - Nucleoproteins: Combination of protein and nucleic acid
 - Mucoproteins: Combination of proteins and carbohydrates (>4%)
 - Glycoproteins: Combination of proteins and carbohydrates(<4%)
 - Chromoproteins: Combination of proteins and coloured pigments.
 - Lipoproteins: Combination of proteins and lipids.
 - Metalloprotein: Combination of proteins and metal ions.
 - Phosphoprotein: Combination of proteins and phosphate group.
- **Derived proteins:** When proteins are hydrolyzed by acids, alkalies or enzymes, the degradation products obtained from them are called derived proteins.

On the basis of nature of Molecules

- **Acidic proteins:** They exist as anion and contain acidic amino acids. e.g. blood groups.
- **Basic proteins:** They exist as cations and are rich in basic amino acids e.g. lysine, arginine etc.



Types of Proteins

There is a total of seven different protein types under which all proteins fall. These include antibodies, contractile proteins, enzymes, hormonal proteins, structural proteins, storage proteins, and transport proteins.

Antibodies

Antibodies are specialized proteins that defend the body against antigens or foreign invaders. Their ability to travel through the bloodstream enables them to be utilized by the immune system to identify and defend against bacteria, viruses, and other foreign intruders in blood. One way antibodies counteract antigens is by immobilizing them so that they can be destroyed by white blood cells.

Contractile Proteins

Contractile proteins are responsible for muscle contraction and movement. Examples of these proteins include actin and myosin. Eukaryotes tend to possess copious amounts of actin, which controls muscle contraction as well as cellular movement and division processes. Myosin powers the tasks carried out by actin by supplying it with energy.

Enzymes

Enzymes are proteins that facilitate and speed up biochemical reactions, which is why they are often referred to as catalysts. Notable enzymes include lactase and pepsin, proteins that are familiar for their roles in digestive medical conditions and specialty diets. Lactose intolerance is caused by a lactase deficiency, an enzyme that breaks down the sugar lactose found in milk. Pepsin is a digestive enzyme that works in the stomach to break down proteins in food—a shortage of this enzyme leads to indigestion.

Other examples of digestive enzymes are those present in saliva: salivary amylase, salivary kallikrein, and lingual lipase all perform important biological functions. Salivary amylase is the primary enzyme found in saliva and it breaks down starch into sugar.



Hormonal Proteins

Hormonal proteins are messenger proteins that help coordinate certain bodily functions. Examples include insulin, oxytocin, and somatotropin.

Insulin regulates glucose metabolism by controlling blood-sugar concentrations in the body, oxytocin stimulates contractions during childbirth, and somatotropin is a growth hormone that incites protein production in muscle cells.

Structural Proteins

Structural proteins are fibrous and stringy, this formation making them ideal for supporting various other proteins such as keratin, collagen, and elastin.

Keratins strengthen protective coverings such as skin, hair, quills, feathers, horns, and beaks. Collagen and elastin provide support to connective tissues like tendons and ligaments.

Storage Proteins

Storage proteins reserve amino acids for the body until ready for use. Examples of storage proteins include ovalbumin, which is found in egg whites, and casein, a milk-based protein. Ferritin is another protein that stores iron in the transport protein, hemoglobin.

Transport Proteins

Transport proteins are carrier proteins that move molecules from one place to another in the body. Hemoglobin is one of these and is responsible for transporting oxygen through the blood via red blood cells. Cytochromes, another type of transport protein, operate in the electron transport chain as electron carrier proteins.

See summary about proteins:

<https://www.youtube.com/watch?v=OCHJr-GVEvw>

<https://www.youtube.com/watch?v=-GKizNL-REA>

Main Functions of Proteins

Proteins:

- Protein is the nutrient that is used in building, repairing, and maintaining body tissues.
- Every tissue and fluid in the body contains protein except bile and urine.
- A protein is made up of amino acids, carbon, hydrogen, carbohydrates, and oxygen.

Functions of proteins:

- The digestive enzymes are made up of proteins that are useful in carrying out digestion.
- The protein acts as a chemical messenger for the interaction between cells, tissues, and organs.
- Regeneration and creation of DNA molecules are done with the help of proteins.
- Receptors are made up of proteins that help in the interaction of a cell with other cells and the external environment.
- The immune system uses antibodies for repairing body cells which are mainly made up of proteins.

FUNCTIONS OF PROTEINS



Digestive enzymes help facilitate chemical reactions



Antibodies support immune function



Support muscle contraction and movement



Support the regulation and expression of DNA and RNA



Provide support to the body



Hormones help coordinate bodily function

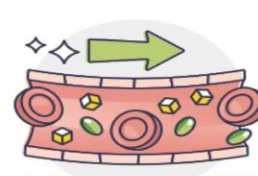

Move essential molecules around the body



Role of protein in the Eye (cornea, lens, retina)

The eye is made up of a number of parts, veins, arteries, and vessels. It contains many unique proteins that can act as auto-antigens. Any damage done to these proteins can cause eye issues. Some such examples include cataracts, glaucoma, macular degeneration, and retinal degenerative diseases.

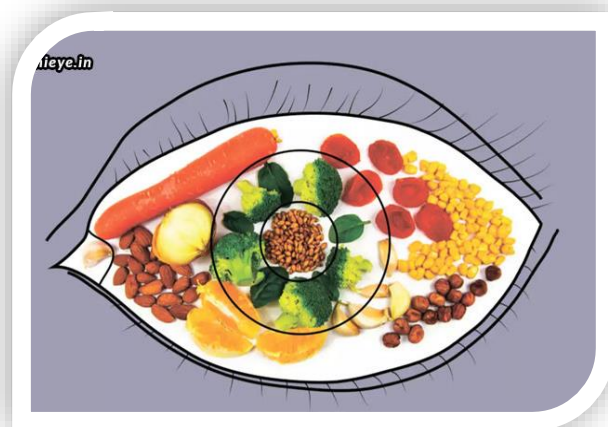

Health Eye problems associated with protein deficiency

Cataracts is one of the most common reasons for blindness in the world, which is present in almost 70% of people that are over 75 years of age. Similarly, macular degeneration is the leading cause of irreversible visual loss in the elderly. There are a number of reasons that can be caused in the condition of macular degeneration, one of the most common symptoms seen being the pigmentation of the retinal pigment. Thus, it is the oxidative stress that damages the proteins, enzymes, and fats in the eye lens, which makes it cloudy and damaged.

H.W / How do the Eyes work?

Ans / see the first course of Chemistry.

Proteins Build up in the Eyes

Eating a healthy and balanced diet rich in proteins can help provide all the necessary nutrients for your eyes. These include fruits, vegetables, and whole grains. While meats are also a good source of protein, but it the fat content and cooking method that helps prepare them to become healthy or unhealthy. So, you need to be very careful while consuming those. You need to limit the consumption of saturated fats from red meats and dairy products, which may increase the risk of macular degeneration.

Sources of Proteins Important for the Eye

- Fish – Salmon is the best kind of fish you can consume, which is rich in Omega-3 fatty acids.
- Eggs – Eggs are rich in Vitamin A, zinc, Lutein, and Zeaxanthin, all which are vital to eye health. Vitamin A safeguards the cornea; Zinc improves the health of the retina; and Lutein and Zeaxanthin lower the chances of getting serious eye conditions.
- Almonds – For all of you vegetarian friends, almonds are the best source of protein for you. They contain Vitamin E, which guards against the unstable molecules that target healthy tissues.
- Oranges – Oranges are rich in Vitamin C, which contribute to healthy blood vessels in the eyes. They can fight the development of cataracts and macular degeneration.
- Carrots – Carrots have Vitamin A and beta carotene, which help the surface of the eye and prevent eye infections and other serious eye conditions.
- Dairy products – Milk and yoghurt contain Vitamin A and Zinc, which protect the cornea and bring vitamin to the eyes from the liver respectively.

It is important to take care of your eyes, but it is even better to keep them prevented against any diseases. Thus, prevention is better than cure; and for the best prevention, it is not only important that you have a healthy diet, but also that you have regular eye checkups.

