



Medical physics

Department of Physical
Therapy Techniques

The first stage

Dr. Muhammad Ajami Abdul

1-The electron theory

Metals are of great importance in our daily lives. Iron is used in automobiles, copper in electrical wiring, silver and gold as jewelry. Metals are characterized by common physical properties: great physical strength, high density, good electrical and thermal conductivities, and high optical reflectivity, which is responsible for their characteristic bright appearance.

1-1 Conduction electrons

What are the conduction electrons?

A valence electron really belongs to the whole crystal, since it can move readily from one ion to its neighbor, and then the neighbor's neighbor, and so on. This mobile electron, which is called a valence electron in a free atom, becomes a conduction electron in a solid. In Na the number of conduction electrons is the same as the number of atoms, and the same is true for K, and also for the noble metals Cu, Ag, Au, all of which are monovalent. In divalent metals-such as Be, Mg, Zn, and Cd-the number of electrons is twice the number of atoms, and so on. We can find the electron concentration by this equation.

$$n = \eta \left(\frac{\rho}{\text{atomic or } M.wt} \right) N_A$$

n is the number of electrons per unit volume,

η is the atomic valence,

N_A is Avogadro's number,

ρ is density of the substance.

2. The Free-electron gas

In the free-electron model, the conduction electrons are assumed to be completely free, except for a potential at the surface. According to this model, the conduction electrons move about inside the specimen without any collisions, except for an occasional reflection from the surface (see figure below) . Because of this, we speak of a free-electron gas.

Q1/ What is the reason for the weakness of the interaction between the conduction electrons?

There are actually two reasons.

1. According to the Pauli exclusion principle, electrons of parallel spins tend to stay away from each other.
2. even if their spins are opposite, electrons tend to stay away from each other, in order to minimize the energy of the system. If two electrons come very close to each other, the coulomb potential energy becomes highly large, and this violates the

Classical free electron theory is based on the following postulates:

1. A solid metal is composed of atoms and the atoms have nucleus, around which there are revolving electrons.
2. In a metal the valance electrons of atoms are free to move throughout the volume of the metal
like gas molecules of a perfect gas in a container
3. The free electrons move in a random directions and collide with either positive ions fixed to the
lattice or other free electrons and collisions are elastic in nature i.e. there is no loss of energy.
4. The movement of free electrons obeys the classical kinetic theory of gasses. The mean K.E. of a free electron is equal to that of gas molecule KT .

$$\left[\begin{array}{c} 3 \\ - \\ 2 \end{array} \right] KT \left[\begin{array}{c} \\ \\ \end{array} \right]$$

5. The electron velocities in a metal obey Maxwell-Boltzman distribution of velocities.
6. The free electrons move in a uniform potential field due to ions fixed in the lattice
7. When an electric field is applied to the metal the free electrons are accelerated. The accelerated electrons move in opposite direction of the applied.
8. The electric conduction is due to the free electrons only.

2-Conductors and Insulators :

We can classify materials generally according to the ability of charge to move through them (What is the classification of materials according to the ability of charge moving through them or according to the conductivity?)

2-1 Conductors are materials through which charge can move rather freely; examples include metals (such as copper in common lamp wire), the human body, and tap water.

- Free electrons are not bound to the atoms.
- These electrons can move relatively freely through the material.
- Examples of good conductors include copper, aluminum and silver.
- When a good conductor is charged in a small region, the charge readily distributes itself over the entire surface of the material.

2-2 Insulators: Electrical insulators are materials in which all of the electrons are bound to atoms.

- These electrons cannot move relatively freely through the material.
- Examples of good insulators include glass, rubber and wood.
- When a good insulator is charged in a small region, the charge is unable to move to other regions of the material.

Convection current :consists of charged particles moving in response to mechanical forces, as opposed to being guided by the electric field (Sections 2.2 and/or 5.1). An example of a convection current is a cloud bearing free electrons that moves through the atmosphere driven by wind.

Conduction current :consists of charged particles moving in response to the electric field and not merely being carried by motion of the surrounding material. In some materials, the electric field is also able to dislodge weakly-bound electrons from atoms, which then subsequently travel some distance before reassociating with other atoms. For this reason, the individual electrons in a conduction current do not necessarily travel the full distance over which the current is perceived to exist.

The distinction between convection and conduction is important because Ohm's Law ,which specifies the relationship between electric field intensity and current – applies only to conduction current.

3-Displacement current is the term in Maxwell's modified

version of Ampère's Circuital Law that enables the electromagnetic wave equation to be derived. It was originally conceived by Maxwell in connection with displacement of the electric particles in his sea of molecular vortices. It was conceived to exist in deepest space and not necessarily to be confined to the immediate vicinity of an electric current circuit. Nowadays, displacement current is introduced as being the term that is needed to make Ampère's Circuital Law consistent with conservation of charge, and it is deemed not to be a real current. Maxwell on the other hand had already added displacement current to Ampère's Circuital Law prior to considering any such matters. It will now be shown that the modern approach to displacement current is heavily flawed and that displacement current makes no difference whatsoever to the issue of the applicability of Ampère's Circuital Law in charge varying situations.

The displacement current:

Observe that the vector field $\mu_0\epsilon_0(\partial E/\partial t)$ appears to form a continuation of the conduction current distribution. Maxwell called it the displacement current, and the name has stuck although it no longer seems very appropriate. To be precise, we can

define a displacement current density J_d , to be distinguished from the conduction current density J , by writing Eq. 1 by this way:

$$\text{curl } \mathbf{B} = \mu_0(\mathbf{J} + \mathbf{J}_d),$$

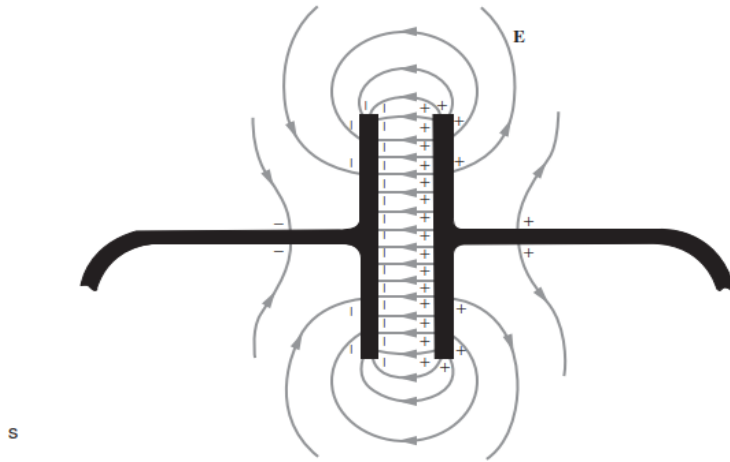

Figuer1:The electric field at a particular instant. The magnitude of E is decreasing everywhere as time goes on.

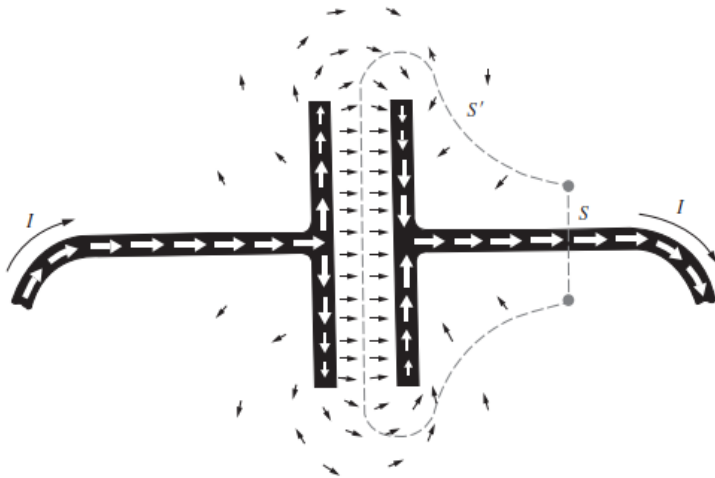

Figuer2:The conduction current (white arrows) and the displacement current (black arrows).

and defining:

$$\mathbf{J}_d \equiv \epsilon_0 \frac{\partial \mathbf{E}}{\partial t} .$$

We needed the new term to make the relation between current and magnetic field consistent with the continuity equation, in the case of conduction currents changing in time. If it belongs there, it implies the existence of a new induction effect in which a changing electric field is accompanied by a magnetic field.

4-Atomic structure

- Modern Atomic Model: An Atom consist of three sub-atomic particle i.e. neutron, proton, and electron.

Name of Particle	Mass	Charge	Symbol
Neutron	Mass of 1H atom	No	${}_0^1n$
Proton	Mass of 1H atom	Unit Positive	${}_1^1p$
Electron	Mass of $\frac{1}{1837}$ times of 1H atom	Unit Negative	${}_{-1}^0e$

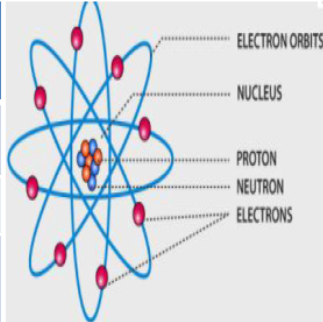

- Nucleus consists of Neutron and Proton.
- Orbit: The path on which electron moves around the nucleus.
- Orbital: Probability of finding electron around the nucleus.
- Centrifugal force: Due to motion of electron they experience outward pull.
- Centrifugal force is counter balance by electrostatic force of attraction between electron and proton.
- Valence electron: The electron in the outer most shell.

-
- Bound Electron: The electron in the shell nearest to the nucleus are held strongly by the electric pull of protons.
 - Total number of electron is equal to the total number of proton in an atom.
 - No. of Electron= No. of Proton

Charging by Conduction and conduction:

1-Charging by conduction

Conduction just means that the two objects will come into actual physical contact with each other (this is why it is sometimes called “charging by contact”).

What is Charging by Conduction?5

- A process of charging a neutral object.
- Involves touching a charged object (A) to a neutral object (B).
- The act of touching or making contact charges Object **B**.

The Result: the charge that Object **B** acquires is the same type of the charge that Object

A. Object A keeps the same type of charge but is less charged than before.

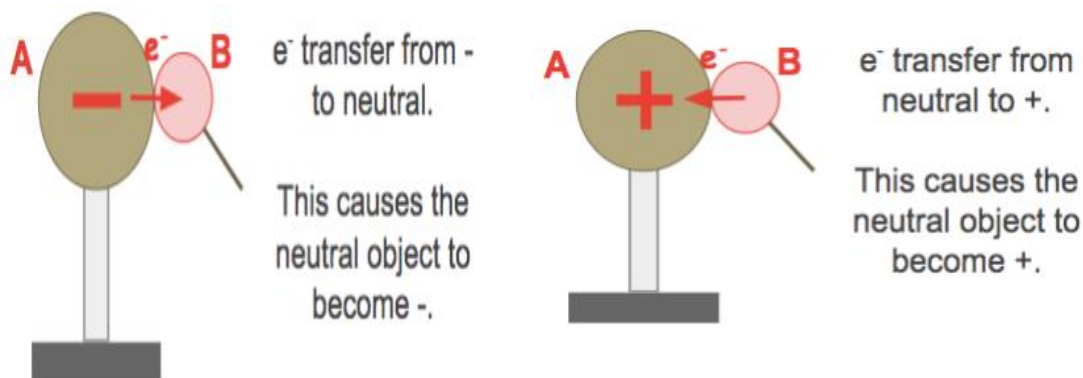

Figuer1:charging by conduction.

- **Charging by Conduction Requires Conductors**

Charging by conduction should be viewed as a charge-sharing event. At contact excess charge is shared by the two objects in order to distribute the charge over a larger area. Insulators can't be charged by conduction since electrons are unable to flow freely across their surface.

2-Charging by Induction

It is possible to charge a conductor without touching it. You do have to follow some special procedures.

- Most important is the use of a grounding wire.
- A grounding wire is simply a conductor that connects the object to the ground.
- Think of the earth as a huge reservoir of charge... it can both gain or donate electrons as

needed. Depending on what the situation is, either electrons will travel up the grounding

wire to the object being charged, or travel down to the ground.

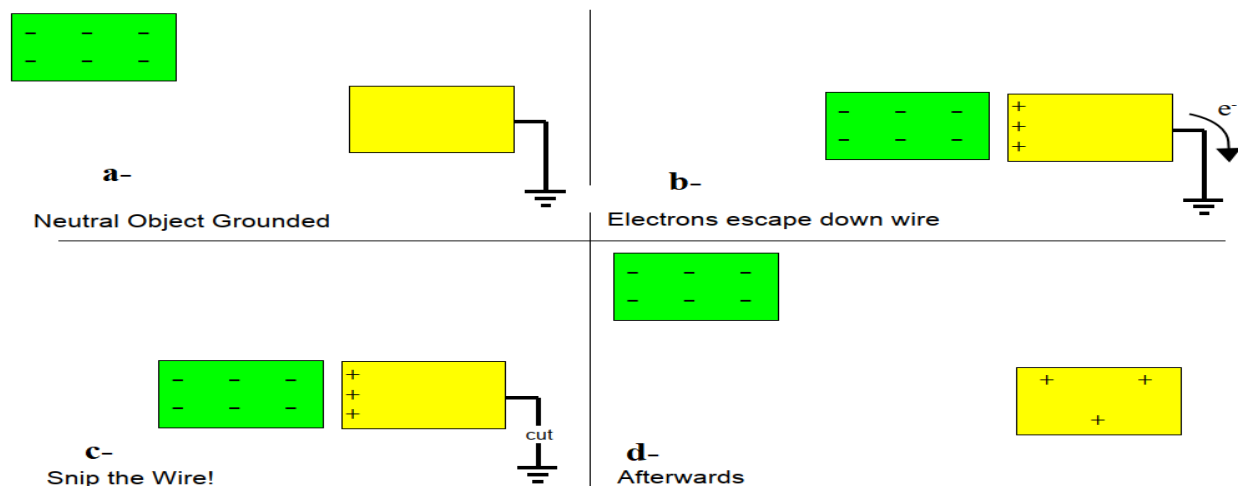

Figuer2: charging by induction

Figure 2,a/: The neutral object is on an insulating stand. It also has a ground wire attached to it.

b/: We bring a negative object nearby. This will cause the electrons to be pushed as far away as possible, and since they are free to move, they do just that. They will travel down the ground wire.

c/: This step is very important. Keeping the negative object nearby we snip the ground wire. Now there is no way for the electrons to travel back up they wire to the originally neutral object. If we had skipped this step and just moved the negative object away without wire and it would be neutral again.

d/: We remove the negative object... now the the original object has a net positive charge.

الشكل 2، a/ الجسم المتعادل موجود على حامل عازل. إضافة الى سلك أرضي متصل به

b/: نحضر جسمًا يحمل شحنة سالبة وقريبا منه , سيؤدي هذا إلى دفع الإلكترونات بعيدًا قدر الإمكان، وبما أنها حرة في الحركة، سوف تنتقل عبر السلك الارضي.

c/ مع إبقاء الجسم المشحون بالشحنة السالبة قريبًا نقوم بقص السلك الأرضي. وبالتالي لا توجد وسيلة للإلكترونات للعودة إلى الأعلى، فهي تتصل بالجسم المتعادل في الأصل. إذا تخطينا هذه الخطوة وقمنا بتحريك الجسم السالب بعيدًا بدون سلك، فسيكون متعادلاً مرة أخرى.

d/ عند إزالة الجسم السالب , سوف يصبح الجسم الأصلي يحمل شحنة موجبة فقط.

Capacitors:

A capacitor is a system of two conductors that carries equal and opposite charges. A capacitor stores charge and energy in the form of electro-static field.

We define capacitance as

$$C = \frac{Q}{V}$$

where

Q = Charge on one plate

V = Potential difference between the plates

المتسعة هو نظام من موصلين يحملان شحنات متساوية ومتعاكسة. تقوم المتسعة بتخزين الشحنة والطاقة على شكل مجال كهروستاتيكي.

- **Capacitors in Combination**

(a) Capacitors in Parallel

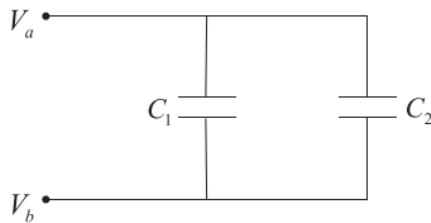

In this case, it's the *potential difference* $V = V_a - V_b$ that is the same across the capacitor.

Figuer3: Capacitors in Parallel

BUT: Charge on each capacitor different

$$\text{Total charge } Q = Q_1 + Q_2$$

$$= C_1V + C_2V$$

$$Q = (C_1 + C_2) v$$

Equivalent capacitance

For capacitors in parallel: $C = C_1 + C_2$

Dr.mohammed Ajmi

(b) Capacitors in Series:

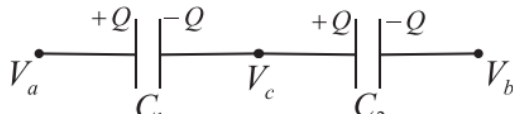

The *charge across capacitors* are the same.

Figuer4: Capacitors in Series:

BUT: Potential difference (P.D.) across capacitors different

$$\Delta V_1 = V_a - V_c = \frac{Q}{C_1} \quad \text{P.D. across } C_1$$

$$\Delta V_2 = V_c - V_b = \frac{Q}{C_2} \quad \text{P.D. across } C_2$$

∴ Potential difference

$$\begin{aligned} \Delta V &= V_a - V_b \\ &= \Delta V_1 + \Delta V_2 \\ \Delta V &= Q \left(\frac{1}{C_1} + \frac{1}{C_2} \right) = \frac{Q}{C} \end{aligned}$$

where C is the Equivalent Capacitance

$$\therefore \boxed{\frac{1}{C} = \frac{1}{C_1} + \frac{1}{C_2}}$$

Capacitor charging:

Let us assume that the capacitor in Figure 5 is initially uncharged. There is no current while switch S is open. If the switch is closed at $t = 0$, however, charge begins to flow, setting up a current in the circuit, and the capacitor begins to charge. Note that during charging, charges do not jump across the capacitor plates because the gap between the plates represents an open circuit. Instead, charge is transferred between each plate and its connecting wire due to the electric field established in the wires by the battery, until the capacitor is fully charged. As the plates become charged, the potential difference across the capacitor increases. The value of the maximum charge depends on the voltage of the battery. Once the maximum charge is reached, the current in the circuit is zero because the potential difference across the capacitor matches that supplied by the battery.

لنفترض أن المتسعة الموجودة في الشكل 5 كان غير مشحونة في البداية. لا يوجد تيار عندما يكون المفتاح S مفتوحًا. إذا كان المفتاح مغلقًا عند $t = 0$ ، تبدأ الشحنة بالتحرك، مما يؤدي إلى إنشاء تيار في الدائرة، وتبدأ المتسعة عملية الشحن. لاحظ أنه أثناء الشحن، لا تقفز الشحنات عبر لوحات المكثف لأن الفجوة بين اللوحات تمثل دائرة مفتوحة. وبدلاً من ذلك، يتم نقل الشحنة بين كل لوحة وسلك التوصيل الخاص بها بسبب المجال الكهربائي الناشئ في الأسلاك بواسطة البطارية، حتى يتم شحن المتسعة بالكامل. عندما تصبح الألواح مشحونة، يزداد فرق الجهد عبر المتسعة. تعتمد قيمة الحد الأقصى للشحن على جهد البطارية. بمجرد الوصول إلى الحد الأقصى للشحن، يصبح التيار في الدائرة صفرًا لأن فرق الجهد عبر المتسعة سوف يتطابق مع فرق الجهد الذي توفره البطارية.

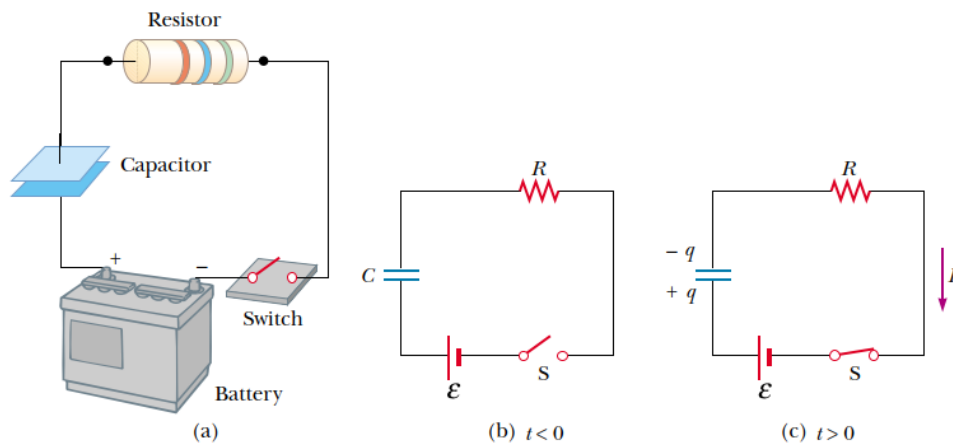

Figuer5: charging an capacitor

To analyze this circuit quantitatively, let us apply Kirchoff's loop rule to the circuit after the switch is closed. Traversing the loop clockwise gives :

لتحليل هذه الدائرة كمياً، نطبق قاعدة حلقة كيرشوف على الدائرة بعد عملية إغلاق المفتاح. اجتياز الحلقة في اتجاه عقارب الساعة يعطي

$$\mathcal{E} - \frac{q}{C} - IR = 0$$

Discharging a Capacitor

Now let us consider the circuit shown in Figure 3, which consists of a capacitor carrying an initial charge Q , a resistor, and a switch. The *initial* charge Q is not the same as the *maximum* charge Q in the previous discussion, unless the discharge occurs after the capacitor is fully charged (as described earlier). When the switch is open, a potential difference Q/C exists across the capacitor and there is zero potential difference across the resistor because $I = 0$. If the switch is closed at $t = 0$, the capacitor begins to discharge through the resistor.

سوف نفترض بان الدائرة الموضحة في الشكل 6, و تتكون من متسعة تحمل شحنة أولية Q ، ومقاومة، ومفتاح. الشحنة الأولية Q ليست هي نفس الشحنة القصوى Q ، إلا إذا حدث التفريغ بعد شحن المتسعة بالكامل. عندما يكون المفتاح مفتوحاً، يوجد فرق جهد Q/C عبر المتسعة ويكون فرق الجهد صفراً عبر المقاومة لأن $I = 0$. إذا كان المفتاح مغلقاً عند $t = 0$ ، تبدأ المتسعة في التفريغ عبر المقاومة.

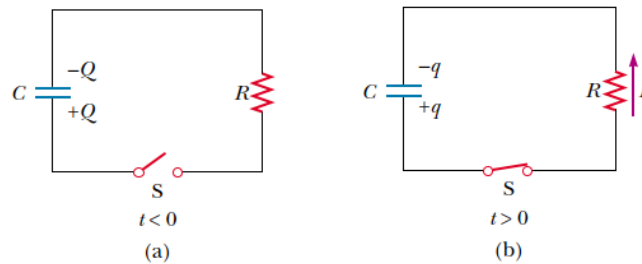

Figuer6: discharge the capacitor.

At some time t during the discharge, the current in the circuit is I and the charge on the capacitor is q . To obtain the appropriate loop equation for the circuit in Figure 6:

$$-\frac{q}{C} - IR = 0$$

Some types of capacitors:

Different Types of Capacitors

The different types of capacitors are following.

1. Electrolytic Capacitor
2. Mica Capacitor
3. Paper Capacitor
4. Film Capacitor
5. Non-Polarized Capacitor
6. Ceramic Capacitor

We will explain the next:

1-Electrolytic Capacitor

Generally, the electrolyte capacitors are used when the large capacitor values are required. The thin metal film layer is used for one electrode and for the second electrode (cathode) a semi-liquid electrolyte solution which is in jelly or paste is used. The dielectric plate is a thin layer of oxide, it is developed electrochemically in production with the thickness of the film and it is less than the ten microns.



2- Mica Capacitor

This capacitor is a group of natural minerals and the silver mica capacitors use the dielectric. There are two types of mica capacitors which are clamped capacitors & silver mica capacitor. Clamped mica capacitors are considered as an obsolete because of their inferior characteristic. The silver mica capacitors are prepared by sandwiching mica sheet coated with metal on both sides and this assembly is then encased in epoxy to protect the environment. The mica capacitors are used in the design calls for stable, reliable capacitor of relatively small.



miga capacitor

3-Paper Capacitor

The construction of paper capacitor is between the two tin foil sheet and they are separated from the paper, or, oiled paper & thin waxed. The sandwich of the thin foils and papers then rolled into the cylindrical shape and then it is enclosed into the plastic capsule. The two thin foils of the paper capacitors attach to the external load.

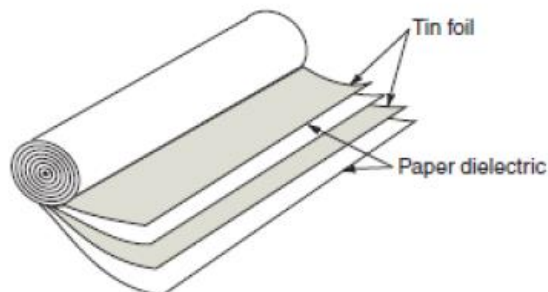

Oscillating discharge of capacitors:

The simplest circuits in electronics engineering consisting of the three most common passive components; one resistor, one inductor and one capacitor creating a series connected RLC circuit. We are interested in studying how the current behaves when the capacitor is charged to an initial voltage (V_0) and switched to discharge through the resistor and uncharged inductor ($I_0 = 0$). Depending on the values of these components one of three types of response can occur. The damping factor will be discussed shortly, and this parameter determines if the response will be underdamped or oscillating, critically damped or overdamped.

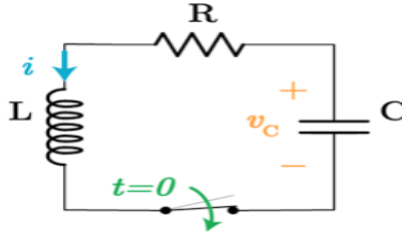

$R = \text{Capacitor ESR} + \text{Discharge Circuit } R$, $L = \text{Capacitor ESL} + \text{Discharge Circuit } L$, $C = \text{Capacitance}$, $V_c = \text{Initial charge voltage}$

The objective subject was to outline the possibilities of discharge current waveforms and what is happening in the transient state as soon as discharge begins. The three cases that are possible for the response are underdamped (oscillatory), critically damped and overdamped and the response type is determined by the ratio between the Neper frequency and the angular resonant frequency of the system. In the underdamped case the inductance is heavily involved in the system causing the signal to oscillate at a specific frequency called the damped resonant frequency in which the current begins lagging the voltage approaching a shift of 90 degrees.

كان الموضوع هو توضيح إمكانيات تفريغ الأشكال الموجية الحالية وما يحدث في الحالة العابرة بمجرد بدء التفريغ. الحالات الثلاث الممكنة للاستجابة هي حالات (متذبذبة)، ومخمدة بشكل خطير، ومفرطة التخميد، ويتم تحديد نوع الاستجابة من خلال النسبة بين تردد نيبير وتردد الرنين الزاوي للنظام. في الحالة غير المخمدة، يكون الحث كبيراً في النظام مما يتسبب في تذبذب الإشارة عند تردد محدد يسمى تردد الرنين المخمد حيث يبدأ التيار متخلفاً عن الجهد الذي يقترب من تحول قدره 90 درجة.

Gold leaf Electroscope.....6

● An electroscope :is made up of a couple of very thin metal leaves that hangdown near to each other. They are connected to a metal rod that extendsupwards, and ends in a knob on the end. The whole apparatus is usually insulated from outside effects by being in a metal container with a mica window to look in at the leaves. A rubber stopper insulates the rod from touching the metal container.

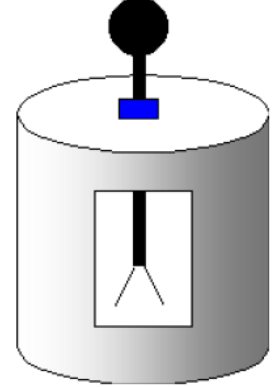

الكشاف الكهربائي: يتكون من ورقتين معدنيتين (ذهب) رفيفتين للغاية تتدليان بالقرب من بعضهما البعض. وهي متصلة بقضيب معدني يمتد إلى الأعلى، وينتهي بمقبض في نهايته. عادةً ما يتم عزل الجهاز بأكمله عن التأثيرات الخارجية عن طريق وضعه في حاوية معدنية بها نافذة من الميكا للنظر إلى الأوراق. سداة مطاطية تعزل القضيب عن لمس الحاوية المعدنية.

The primary purpose of the apparatus is to detect the presence of and measure the magnitude of a static electric charge. A charge is either induced or conducted through the metal plate on the top of the device. The gold leaf mounts to the central rod, and deflects due to the charge .

الغرض الأساسي من الجهاز هو اكتشاف وجود شحنة كهربائية ساكنة وقياسها. يتم تحفيز الشحنة أو إجراؤها من خلال اللوحة المعدنية الموجودة أعلى الجهاز. تتصاعد ورقة الذهب إلى القضيب المركزي، وتنحرف بسبب الشحنة الموجودة .

You can only do things to the metal ball at the top, since everything else is insulated inside the metal can.

- If you bring a charged object near the top ball, electrons will either move out of it or in to it.
- This will result in changes in the charges on the metal leaves inside the electroscope.

Imagine what happens to the metal leaves if a charged object is brought nearby...

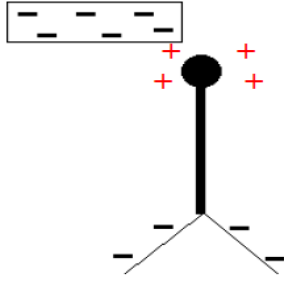

Illustration 5a: In this situation a negative object is brought nearby the electroscope. This causes free moving electrons in the electroscope to move down into the leaves, leaving the top positive. Since the leaves both have negative charge they repel each other and move apart.

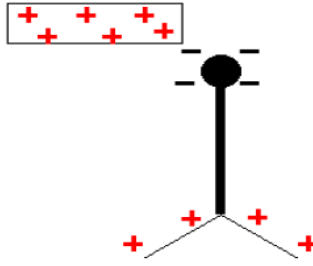

Illustration 5b: Bring a positive object nearby and the free electrons in the electroscope all start moving up towards the top. This means the bottom has a net positive charge. The leaves will spread apart again.

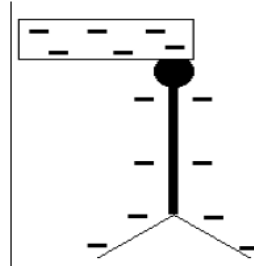

Illustration 5c: Touch the electroscope with any charged object and you'll give it an overall charge by conduction. The leaves will stay spread apart even if you remove the object.

. **An electrostatic field:** is produced by a static charge distribution. A typical example of such a field is found in a cathode-ray tube.

المجال الكهروستاتيكي: ينتج عن توزيع الشحنات الساكنة. ومثال على هذا المجال في أنبوب أشعة الكاثود.

Electrostatics is a fascinating subject that has grown up in diverse areas of application. Electric power transmission, X-ray machines, and lightning protection are associated with strong electric fields and will require a knowledge of electrostatics to understand and design suitable equipment. The devices used in solid-state electronics are based on electrostatics. These include resistors, capacitors, and active devices such as bipolar and field effect transistors, which are based on control of electron motion by electrostatic fields.

تعد الكهرباء الساكنة موضوعاً مهماً نشأ في مجالات تطبيقية مختلفة. حيث يرتبط نقل الطاقة الكهربائية وآلات الأشعة السينية والحماية من الصواعق بالمجالات الكهربائية القوية وسيطلب معرفة بالكهرباء الساكنة لفهم وتصميم المعدات المناسبة. تعتمد الأجهزة المستخدمة في إلكترونيات الحالة الصلبة على الكهرباء الساكنة. وتشمل هذه المقاومات والمتسعات والأجهزة النشطة مثل الترانزستورات ثنائية القطب والترانزستورات ذات التأثير الميداني، والتي تعتمد على التحكم في حركة الإلكترون بواسطة المجالات الكهروستاتيكية.

Electrostatics is the theory of the electric field in conditions in which its behavior is independent of magnetic fields, including

- 1-The electric field associated with fixed distributions of electric charge
- 2-Capacitance (the ability of a structure to store energy in an electric field)
- 3-The energy associated with the electrostatic field
- 4-Steady current induced in a conducting material in the presence of an electrostatic field (essentially, Ohm's Law)

The Current

1-Current is the number of coulombs per second flowing out of a power source, past a point on a wire, or through something (light bulb, motor, radio, ...).

2- Current is usually represented by the letter I in equations, and the unit of current is the ampere, defined to be one coulomb per second.

1- Ohm's Law is $V = IR$.

- V is the difference in electric potential (in volts) between two points in a circuit.
- I is the current flowing along the path between those two points.

Definition: The meaning of Ohm's Law is that voltage V is proportional to current I.

- R is the proportionality constant between the voltage V and the current I. R is called the resistance, the unit of resistance is the Ohm, represented by a Greek uppercase omega: Ω .

Ohm's Law, the proportionality between voltage and current, is true for many things that conduct current but not for everything. Light bulbs are an example of something that conducts current but does not obey Ohm's Law. If you apply different voltages to a light bulb and measure the light bulb currents, you get different values of the ratio V/I . This makes it impossible to assign a resistance R to a light bulb. Things which do have resistance always yield the same V/I ratio no matter what voltage you apply to it. Then it is possible to say that $V/I = R$ is the resistance, because the ratio is always the same.

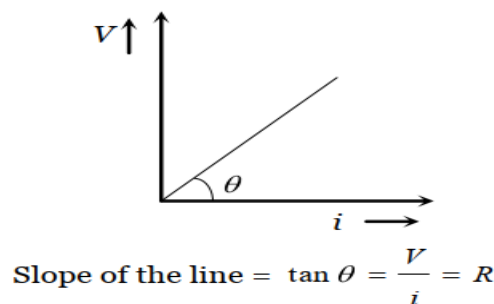

2-The Resistance and its types:

1-definition : The property of substance by virtue of which it opposes the flow of current through it, is known as the resistance.

(2) Cause of resistance of a conductor : It is due to the collisions of free electrons with the ions or atoms of the conductor while drifting towards the positive end of the conductor.

(3) Formula of resistance : For a conductor if l = length of a conductor A = Area of cross section of conductor, n = No. of free electrons per unit volume in conductor,

τ = relaxation time then resistance of conductor

$$R = \rho \frac{l}{A} = \frac{m}{ne^2\tau} \cdot \frac{l}{A}$$

Where ρ = resistivity of the material of conductor

(4) Unit and dimension : It's S.I. unit is Volt/Amp. or (Ω) Ohm

Types of resistance:

- **Linear Resistance**

- Variable Resistors : Variable resistors are those whose values can be varied manually, according to the requirement

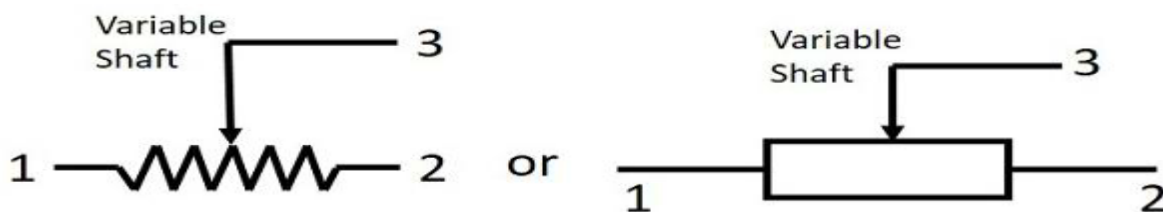

1-Variable Resistance

- A Potentiometer is simply called as a Pot. This is a three-terminal resistor having a shaft which slides or rotates. A potentiometer also measures the potential difference voltage in a circuit. Used as a volume controller in TV and Music systems.

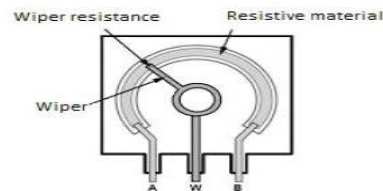

A Rheostat can be simply called as a Wire wound resistor. Rheostat is used to control current. It was replaced by switching electronic devices, as it have lower efficiency.



Single tube Rheostat



Double tube Rheostat

2-Fixed Resistors

- Fixed resistors are one type of linear resistors. A resistor is said to be a fixed resistor, if its value is fixed and its value is determined at the time of manufacturing itself.



3-Chemical effects of electric current :-

When electric current passes through a conducting solution, it causes chemical reactions. This is called chemical effect of electric current.

Chemical effect of electric current may cause :-

- i) Formation of gas bubbles at the electrodes.
- ii) Deposit of metal on the electrodes.
- iii) Change in colour of the solution.

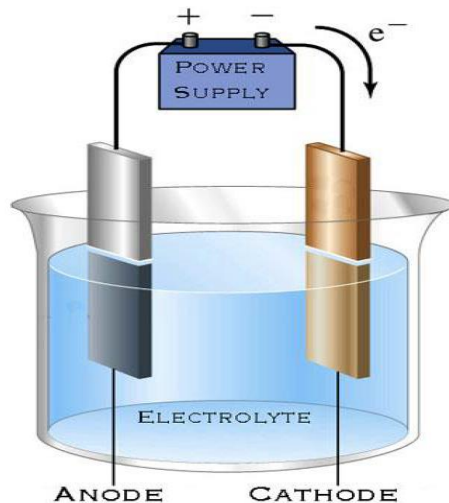

4-Cell and battery

The device which converts chemical energy into electrical energy is known as electric cell.

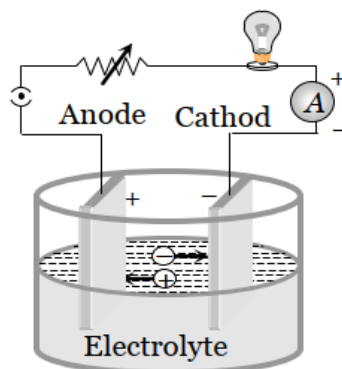

- (1) A cell neither creates nor destroys charge but maintains the flow of charge present at various parts of the circuit by supplying energy needed for their organised motion.
- (2) Cell is a source of constant emf but not constant current.
- (3) Mainly cells are of two types :
 - (i) Primary cell : Cannot be recharged
 - (ii) Secondary cell : Can be recharged
- (4) The direction of flow of current inside the cell is from negative to positive electrode while outside the cell is form positive to negative electrode.
- (5) A cell is said to be ideal, if it has zero internal resistance.
- (6) Emf of cell (E) : The energy given by the cell in the flow of unit charge in the whole circuit (including the cell) is called it's electromotive force (emf) i.e. emf of cell is:

$$E = \frac{W}{q}$$

The potential difference across the terminals of a cell when it is not given any current is called it's emf.

Potential difference (V) of Cell: The energy given by the cell in the flow of unit charge in a specific part of electrical circuit (external part) is called potential difference. It's unit is also volt or The voltage across the terminals of a cell when it is supplying current to external resistance is called potential difference or terminal voltage. Potential difference is equal to the product of current and resistance of that given part i.e. $V = iR$

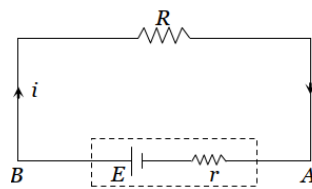

Grouping of cell.

Group of cell is called a battery.

(1) **Series grouping** : In series grouping anode of one cell is connected to cathode of other cell and so on.

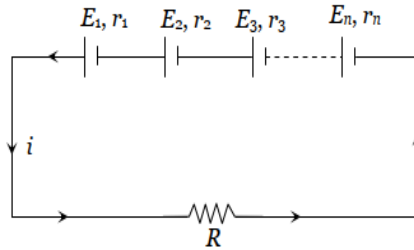

(2) **Parallel grouping** : In parallel grouping all anodes are connected at one point and all cathode are connected together at other point.

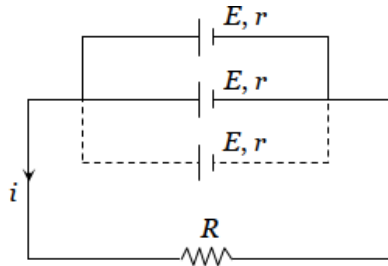

Concepts

- ☞ In series grouping of cell's their emfs are additive or subtractive while their internal resistances are always additive. If dissimilar plates of cells are connected together their emfs are added to each other while if their similar plates are connected together their emfs are subtractive.

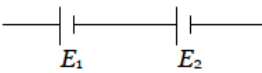

$$E_{eq} = E_1 + E_2 \quad \& \quad r_{eq} = r_1 + r_2$$

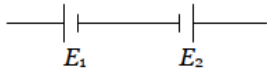

$$E_{eq} = E_1 - E_2 \quad (E_1 > E_2) \quad \& \quad r_{eq} = r_1 + r_2$$

- ☞ In series grouping of identical cells. If one cell is wrongly connected then it will cancel out the effect of two cells e.g. If in the combination of n identical cells (each having emf E and internal resistance r) if x cell are wrongly connected then equivalent emf $E_{eq} = (n - 2x)E$ and equivalent internal resistance $r_{eq} = nr$.

- ☞ In parallel grouping of two identical cell having no internal resistance

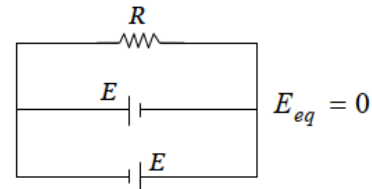
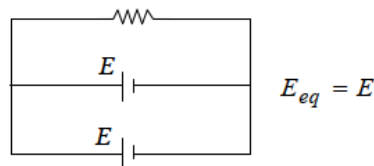

- ☞ When two cell's of different emf and no internal resistance are connected in parallel then equivalent emf is indeterminate, note that connecting a wire with a cell but with no resistance is equivalent to short circuiting. Therefore the total current that will be flowing will be infinity.

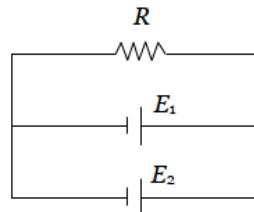

5-Thermal effect of electrical current:

When current flows through a conductor, heat energy is generated in the conductor. The heating effect of an electric current depends on three factors:

- The resistance, R of the conductor. A higher resistance produces more heat.

- The time, t for which current flows. The longer the time the larger the amount of heat produced
- The amount of current, I . the higher the current the larger the amount of heat generated.

Hence the heating effect produced by an electric current, I through a conductor of resistance, R for a time, t is given by $H = I^2Rt$. This equation is called the Joule's equation of electrical heating.

6-Electrolytes and Electrolysis

1- The substances whose aqueous solution undergo decomposition into ions when electric current is passed through them are known as **electrolytes** and the whole process is known as electrolysis or electrolytic decomposition.”

Solutions of acids, bases, salts in water and fused salts etc.

are the examples of electrolytes. Electrolytes may be weak or strong. Solutions of cane sugar, glycerine, alcohol etc., are examples of non-electrolytes.

(2) **Electrolytic cell or Voltmeter** : The device in which the process of electrolysis or electrolytic decomposition is carried out is known as electrolytic cell or voltmeter.

(i) Voltmeter converts electrical energy into chemical energy.

(ii) The electrode on which oxidation takes place is called anode (or +ve pole) and the electrode on which reduction takes place is called cathode (or -ve pole)

(iii) During electrolysis in voltmeter cations are discharged on cathode and anions on anode.

(iv) In voltmeter, outside the electrolyte electrons flow from anode to cathode and current flow from cathode to anode.

7-Ionization of gasses and thermoionic emission

- **Thermonic Emission:**

You will remember that metallic conductors contain many free electrons, which at any given instant are not bound to atoms. These free electrons are in continuous motion. The higher the temperature of the conductor, the more agitated are the free electrons, and the faster they move. A temperature can be reached where some of the free electrons become so agitated that they actually escape from the conductor.

They "boil" from the conductor's surface. The process is similar to steam leaving the surface of boiling water. Heating a conductor to a temperature sufficiently high causing the conductor to give off electrons is called THERMIONIC EMISSION. The idea of electrons leaving the surface is shown in figure .

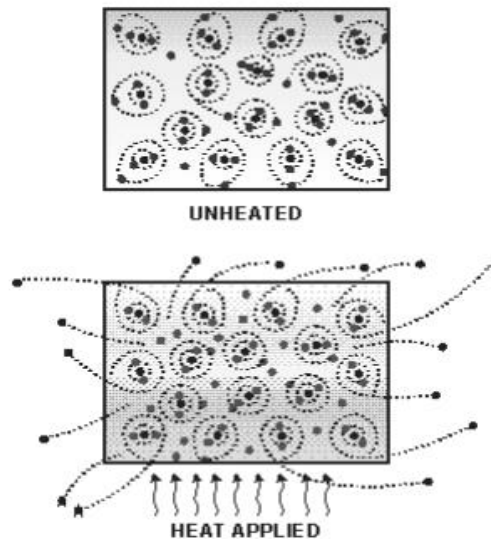

Thermionic emission.

- **Electron emission from a solid cathode can occur via two pro-**

Cesses:

1-electrons can be energized above the potential barrier at the surface, called the work function, or

2-electrons can tunnel through the potential barrier.

The former, called thermionic emission when electrons are excited by heat, typically requires cathode temperatures $\sim 10^3$ K. The latter, called field emission, occurs when a high voltage thins the potential barrier, and typically requires the cathode electric field to be greater than $\sim 10^8$ V m⁻¹. When the cathode is both at an elevated temperature and an electric field is applied, the magnitude of both of these requirements can be reduced—the so-called thermo-field regime. Historically, these emission processes have been considered primarily in vacuum, with well-known theories establishing the relevant current density relationships

Recently, there has been greater interest in understanding emission behavior at elevated pressures, including near and at atmospheric pressure. One of the primary reasons is that these emission processes can play an important role in electron injection in gas discharges. Thermionic emission, for example, is known to be a key process in arc formation, and models for thermionic emission in arcs have been recently developed. Plasma-enhanced thermionic energy conversion also has a long history, and is a key example of thermionic emission at pressures well above vacuum.

8-Electronic Tubes:

The operation of tubes is based on the thermionic effect. Metals have some electrons able to move between different atoms, occasionally even escaping the material spontaneously. When the metal is heated, the speed of electrons is increased, enabling many more to escape. This phenomenon is used in the tubes, where an alloy of metals prone to lose electrons is heated (typically by a red hot filament) and placed close to a cold electrode that can receive them. A voltage is applied between these electrodes, creating an electric field that directs the free electrons.

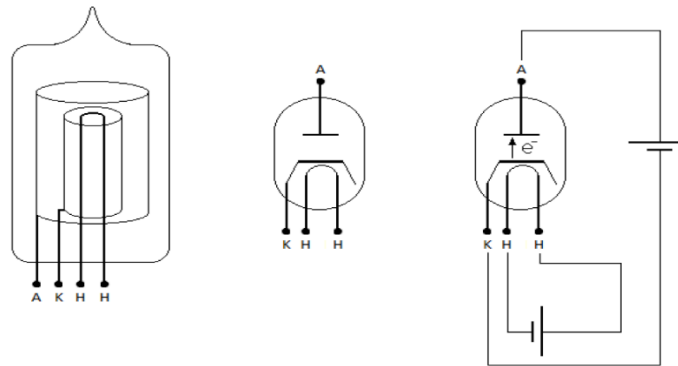

Fig. – From left to right: structure of an indirectly heated **diode**, symbol used in a circuit, electrons flow occurs when the anode is made positive with respect to cathode. Note the cathode heating circuit.

It thus allows current to flow in a single direction (the hot electrode, cathode, can lose electrons to the cold one, anode). The device described is called diode (two electrodes between which a current can flow in one direction). If it includes a third electrode (control), then it is a triode. The potential of the third electrode modifies the existing electric field and thus alters the current (amount of electrons traveling per time unit).

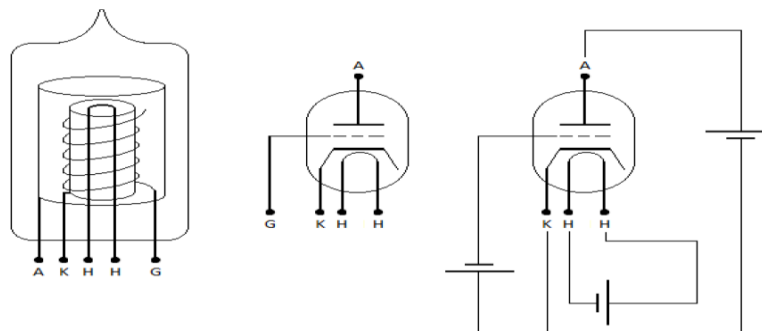
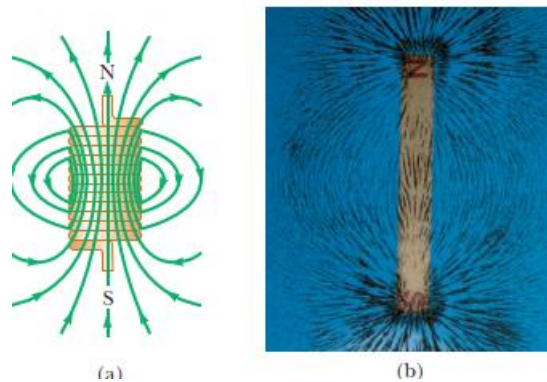

Fig. – From left to right: structure of an indirectly heated **triode**, symbol used in a circuit, electrons flow occurs when the anode is made positive with respect to cathode. The current that is developed between the anode (A) and cathode (K) is dependent on the voltage between grid (G) and cathode.

1-The magnetic field produced by a current in a coil of wire:

The magnetic field produced by a current in a coil of wire: gives us a hint as to what causes certain materials to exhibit strong magnetic properties. Earlier we found that a coil like the one shown in Figure ,a/ has a north pole and a south pole. In general, any current loop has a magnetic field and therefore has a magnetic dipole moment, including the atomic-level current loops described in some models of the atom.



2-A transformer:

A transformer: is an electrical device that transfers energy from one electrical circuit to another by magnetic coupling without using any physical connection between them.

- Any device, which provides impedance matching between certain circuits and isolation between other circuits, may be referred as a 'Hybrid'.
- Example: Transformer, a resistance bridge, or a wave-guide device for Microwave Frequencies.

- Transformer is used to convert between high and low voltages and for impedance transformation.
- It works on the principle of mutual inductance between two (or more) coils.
- It allows us to 'step up' or 'step down' the magnitude of an a.c. voltage by an amount, which depends upon the transformer's *turns ratio* between the coils.
- Turns ratio = N_p / N_s , also, $\frac{N_p}{N_s} = \frac{V_p}{V_s}$

Where N_p is the no. of turns in primary winding and N_s is the no. of turns in secondary winding

- Relation between the primary and the secondary current is described as ,

$$\frac{N_p}{N_s} = \frac{I_s}{I_p}$$

Transformer power can be calculated by one of the formulae

$$P = I_s V_s = I_p V_p$$

Efficiency of transformer is given as $\eta = \frac{P_s}{P_p}$

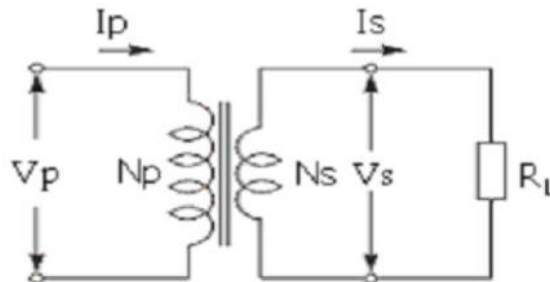
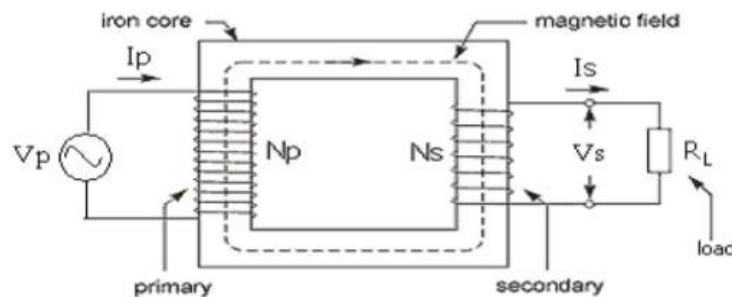

3-Weber and Ewing's Molecular Theory

This theory was first advanced by Weber in 1852 and was, later on, further developed by Ewing in 1890. The basic assumption of this theory is that molecules of all substances are inherently magnets in themselves, each having a N and S pole. In an unmagnetised state, it is supposed that these small molecular magnets lie in all sorts of haphazard manner forming more or less closed loops. According to the laws of attraction and repulsion, these closed magnetic circuits are satisfied internally, hence there is no resultant external magnetism exhibited by the iron bar. But when such an iron bar is placed in a magnetic field or under the influence of a magnetising force, then these molecular magnets start turning round their axes and orientate themselves more or less along straight lines parallel to the direction of the magnetising force. This linear arrangement of the molecular magnets results in N polarity at one end of the bar and S polarity at the other (Fig.).

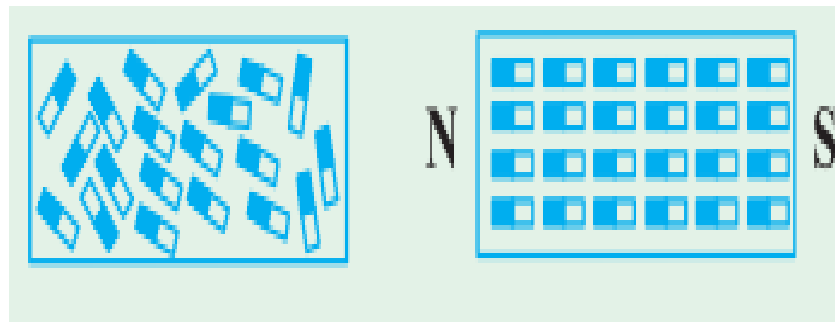

As the small magnets turn more nearly in the direction of the magnetising force, it requires more and more of this force to produce a given turning moment, thus accounting for the magnetic saturation. On this theory, the hysteresis loss is supposed to be due to molecular friction of these turning magnets, shows in fig.

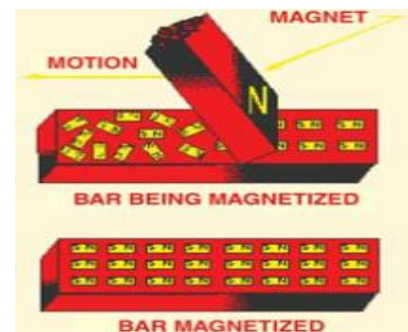

4-Magnetic affect of electric current; 4-1

Take a straight thick copper wire and place it between the points X and Y in an electric circuit, as shown in Fig. 13.1. The wire XY is kept perpendicular to the plane of paper. n Horizontally place a small compass near to this copper wire. See the position of its needle. n Pass the current through the circuit by inserting the key into

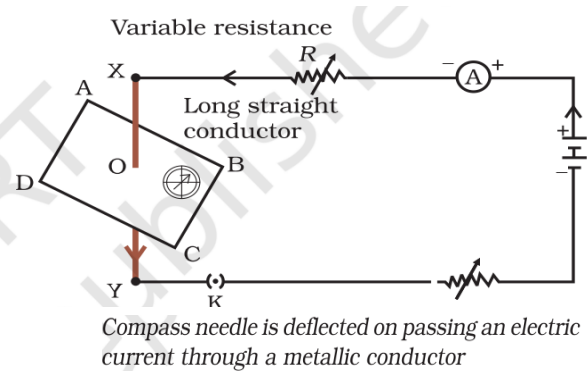

the plug. n Observe the change in the position of the compass needle.

We see that the needle is deflected. What does it mean? It means that the electric current through the copper wire has produced a magnetic effect. Thus we can say that electricity and magnetism are linked to each other. Then, what about the reverse possibility of an electric effect of moving magnets? In this Chapter we will study magnetic fields and such electromagnetic effects. We shall also study about electromagnets and electric motors which involve the magnetic effect of electric current, and electric generators which involve the electric effect of moving magnets.

5-Hot Wire type and thermocouple type meter:4-3,

How a Thermocouple Works It is commonly known that a thermocouple consists of a pair of dissimilar wires joined at one end. This connecting point is known as a measuring junction, but in fact, the junction itself doesn't really 'measure' anything. It simply joins the two wires at one place, and ensures that there can be no electrical potential difference between the wires at that point. Thus, the sole purpose of the 'junction' is to establish a starting point from which a thermoelectric voltage can be developed.

There is a popular, and very misleading, misconception of how a thermocouple operates. In this erroneous 'model', it is imagined that the thermocouple's 'hot' (measuring) junction somehow functions as an electrical source, and that the junction itself produces the thermocouple's small signal voltage. This concept is

simply not true. The actual thermoelectric effect is an extended and continuous one that is distributed along the entire length of the thermocouple conductors. The process is driven by the temperature differences, or gradients, through which these conductors pass.

The key point here is that a thermocouple electromotive force (emf), or voltage, is developed from the measuring junction rather than by that junction. It follows that throughout the circuit beyond this starting point or junction, the thermocouple conductors must be electrically insulated from each other, and must remain so under all operating conditions, so that a useful output signal may be realized. One helpful way of visualizing a thermocouple is to consider a hypothetical and greatly idealized application in which there are three temperature zones as shown in Fig. One zone, where the temperature is being measured, is uniformly hot. Another, containing the reference junction and instrument connections, is taken to be at a cooler, and likewise uniform, ambient temperature.

And in between is a zone within which the temperature is assumed to vary in a linear manner with distance, decreasing smoothly from the hotter to the cooler temperature.

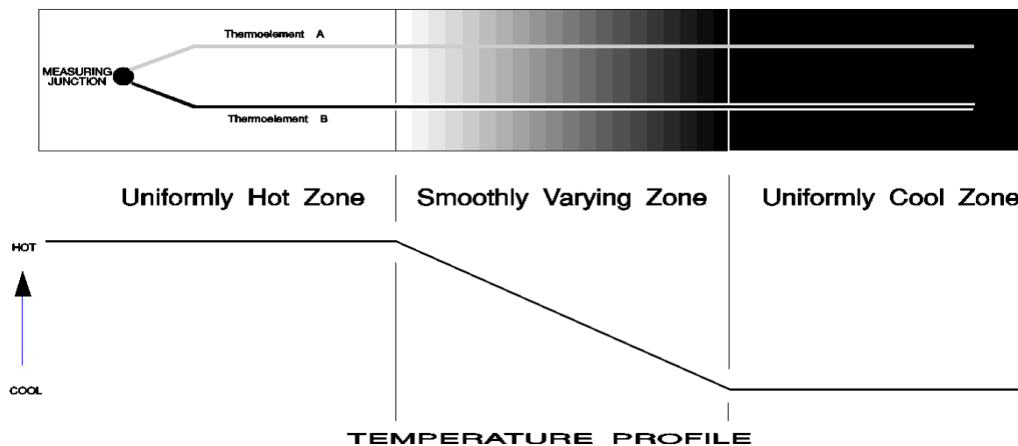

Hypothetical and idealized thermocouple installation.

Thermocouple Type s

1 - **Base metal types**-A primary consideration in choosing which thermocouple type to use in a given circumstance is

the range of temperatures over which the device is to be used. Some of the other selection

factors to be addressed include suitability for the conditions of use and expected service life.

- **Type T, Copper (+) vs. Constantan (nickel-45%copper) (-).** This type is moisture resistant, very stable, and useful to 370°C (700°F) in air, a temperature limit imposed primarily by oxidation of the copper element. When used in vacuum or in reducing or inert atmospheres, operation at somewhat higher temperatures may be possible. It is also suitable for subzero use down to -200°C (-370°F), but stock materials are not normally pretested in this range, so special selection and additional calibration of materials is usually required for such use. Neither wire is magnetic, but visual identification by metal color is easy.
- **Type J, Iron (+) vs. Constantan (nickel-45%copper) (-).** These thermocouples are suitable for use in vacuum, air, reducing, or oxidizing atmospheres to 760°C (1400°F) in the heavier gage sizes. Rapid oxidation of the iron wire at temperatures above 540°C (1000°F) limits the expected service life of the finer sized wires. Type J wires of any size should not be used in sulfurous atmospheres above 540°C (1000°F). Subzero use of this type is limited because of rusting and embrittlement of the iron conductor. The positive (iron) wire is strongly magnetic and the negative one is non-magnetic.
- **Type E, Chromel (nickel-10%chromium) (+) vs. Constantan (nickel-45%copper) (-).** Type E is recommended for use to 900°C (1600°F) in oxidizing or inert atmospheres. This type is also quite suitable for low temperature work down to about -230°C (-380°F), and develops the highest output emf of any standardized type. For subzero work, special selection and testing is usually required. Type E thermocouples are vulnerable to sulfur attack and should not

be exposed to atmospheres containing this substance. These thermocouples perform best in clean oxidizing atmospheres. They are not recommended for use under partially oxidizing conditions, nor when subjected to alternating cycles of oxidation and reduction, or in vacuum, except for short time periods. The wires of this type can be difficult to identify because neither one is magnetic and coloration is similar, but the negative leg appears a little 'warmer' in color than the positive one.

- **Type K, Chromel** (nickel-10%chromium) (+) vs. **Alumel** (nickel-5%aluminum and silicon) (-). Thermocouples of this type are suitable for use in oxidizing or inert atmospheres at temperatures up to 1260°C (2300F), These thermocouples are the traditional base-metal choice for high-temperature work. Type K is quite vulnerable to sulfur attack and should not be exposed to sulfur-containing atmospheres. These thermocouples perform best in clean oxidizing atmospheres and, except for short time periods, are not recommended for use under partially oxidizing conditions, in vacuum, or when subjected to alternating cycles of oxidation and reduction. Identification of these wires is usually made by magnetic response. The positive leg is non-magnetic, while the negative one shows a moderately magnetic response

2- Noble metal types

The following three letter-designated types are made from the precious metals, platinum and rhodium, and as a consequence are more costly than the base-metal types described above. But these thermocouples do operate at higher temperatures than any of the base-metal types, and it is also possible to recover a significant portion of their initial cost by reclaiming the used scrap metal.

- **Type S, Platinum-10%rhodium** (+) vs. **Platinum** (-). Type S is recommended for continuous use in air or inert atmospheres in the temperature range 0 to 1480°C (32 to 2700°F). It is quite stable and capable of long operating life when used in clean, favorable conditions. When used above 1100°C (2000°F), Type S must be protected from exposure to metallic and non-metallic vapors. It is therefore not suitable for direct insertion into metallic protecting tubes. Long operation times at very high temperatures can produce large grain growth leading

to mechanical failure of the negative thermoelement. This type has the same uses as type R, but is not interchangeable with it.

- **Type R, Platinum-13%rhodium (+) vs. Platinum (-).** This type is recommended for continuous

use in air or inert atmospheres in the temperature range 0 to 1480°C (32 to 2700°F). It is quite stable and capable of long operating life when used in clean, favorable conditions. When used above 1100°C (2000°F), these thermocouples must be protected from exposure to metallic and non-metallic vapors. Type R is not suitable for direct insertion into metallic protecting tubes. Long periods of operation at very high temperatures can produce large grain growth leading to mechanical failure of the negative thermoelement. This type has the same uses as type S, but is not interchangeable with it.

Measurement of high frequency and alternate current with meters:4-6

Features of current measurement.

Currents in industry can often be measured directly with electromagnetic and electrodynamic ammeters. Electrodynamic ammeters are characterized by greater accuracy. The measuring range of the electromagnetic ammeter is extended by changing the number and diameter of the windings of the windings of its coil or by using shunts. The applications to extend the range for measuring currents at low often find current transformers. As the frequency of current measurement increases, the accuracy of electromagnetic and electrodynamic ammeters decreases sharply. At high frequencies their use is impossible due to the reactive nature of their internal resistance and the increasing influence on the parasitic capacitance.

The equivalent circuit of an ammeter (regardless of its type) in the high ones often has the form shown in Fig.1. According to the scheme, RA denotes the internal active resistance of the ammeter with LA and CA own parasitic inductance and parasitic capacitance of the ammeter; Cp1 and Cp2 - the parasitic capacitances of terminals 1 and 2 relative to ground.

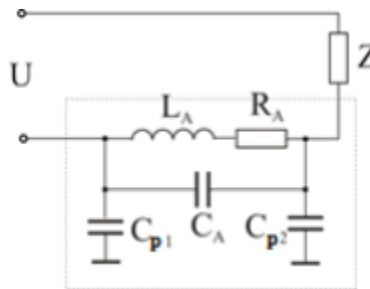

The equivalent circuit shows that the total resistance of the ammeter is complex and depends on the frequency, therefore

1) with the increase of the frequency of the reactance of the device does not increase and this influence

on the value of the measured current;

2) the parasitic reactive elements determine the natural resonant frequency of the ammeter, which is as high as these elements have smaller values. If the measurement frequency is equal to or close to the resonant frequency of the ammeter, the measurement mode of the circuit will be severely disturbed and the measured current value will differ significantly from the actual value. To measure current at high currents, it is often recommended to include an ammeter in lower potential circuits. In this case the shunting of the parasitic capacitances is reduced (Fig.2).

The higher the frequency of current measurement, it is more difficult to create an ammeter that meets these requirements. Therefore, measuring current with a frequency higher than, for example, 3GHz is not possible. The estimation of currents with such currents is often done indirectly by determining more accessible for measurement quantities such as voltage, power, field strength, etc.

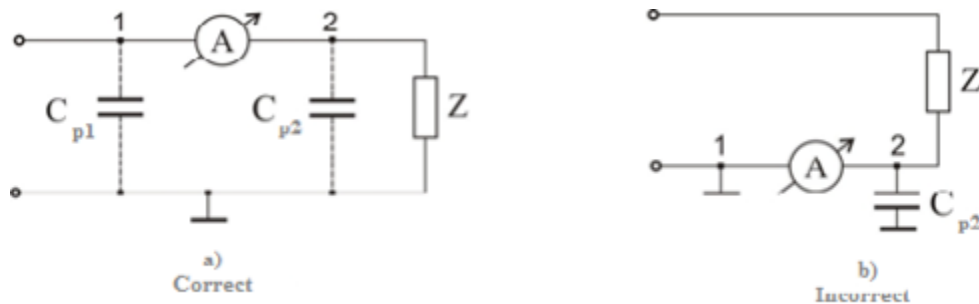

ammeters based on the conversion of alternating current into direct current are most often used

to measure alternating currents over a wide frequency range. These are:

- 1) ammeters with detectors for average value;
- 2) thermoelectric ammeters;
- 3) electrodynamic;
- 4) photoelectric;
- 5) ammeters with conversion of current into voltage on reference resistance.

6-High frequency power measurement.

Absorption wattmeters for measuring high frequency power.

Absorption-type wattmeters consume power during measurement and they consist of three main

structural parts:

- Electricity dissipation load.
- Device for measuring the value of power dissipated on the load.
- Device for reading the value of the measured power.

It is necessary to know the electrical characteristics of the load, which must remain constant throughout the range of temperature, frequency and power. It should be noted that the load is connected to the transmission line that supplies the measured

power. In this case, the coupling used must correspond to the frequency range and the measuring range of the measured power. By measuring the thermal effect obtained from the electric power on the load, direct readings of the power can be made. Another similar method is to measure the voltage and current flowing through the load, and from the values obtained is calculated the value of power. For some appliances, the first two parts are combined, as it is necessary to use all the power received at the input of the appliance. An absorption wattmeter for measuring power by measuring the input voltage is shown in Fig.2.28.

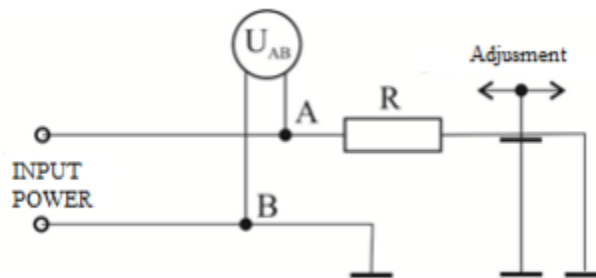

Load resistance is designed to provide an active load with a constant value for a certain frequency range. The resistance value is chosen to allow the wattmeter to be connected to a suitable power transmission line. In this way, the voltage value can be measured at any point on the transmission line before the switch-on point of the resistor by means of a voltage measuring probe. The measured voltage can be converted into power using the equation $P = U^2 / R$. The wattmeter scale is calibrated for direct power reading in watts. Thus, if the voltage meter has a linear scale, the power will be read from a scale plotted on a quadratic law.

7-Electromagnetic induction: 4-5

Michael Faraday's experiment: Changing current

in the primary coil results in surges of current in the secondary coil. The effect is stronger if both coils are wound around an iron ring. The primary coil creates a magnetic field that goes through the secondary coil, too. If the magnetic field changes with time, an electromotive force (EMF) develops in both coils. Faraday has seen this effect on the secondary coil, as shown in the figure.

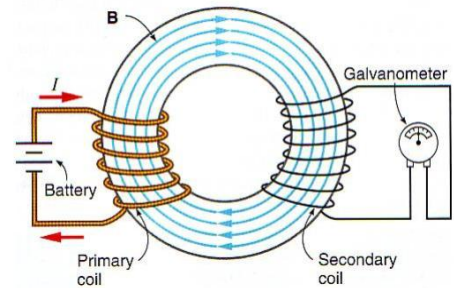

One year later Joseph Henry detected the EMF in the primary coil, the so-called self-induction (in fact he used only one coil in his experiments). Electromotive force in a coil can also be produced by changing the magnetic field as a result of the motion of a magnet. Moreover, moving a wire in a constant magnetic field produces an EMF in it. The latter is used in generators of electric current, where a coils rotate in the magnetic field created by permanent magnets.

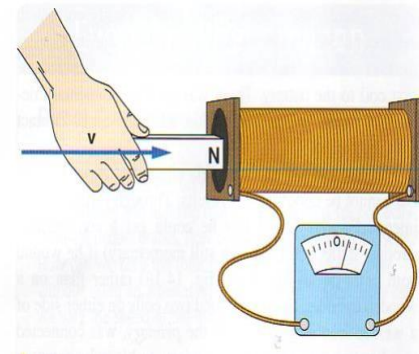

Physical nature of the EMF in Faraday's experiments: Changing magnetic field in time creates an electric field with closed lines. This electric field is different from the static electric field that originates and terminates on electric charges. The structure of this field is similar to that of magnetic field that also has closed lines.

$$\Phi = \mathbf{B} \cdot \mathbf{n}S = BS \cos \theta$$

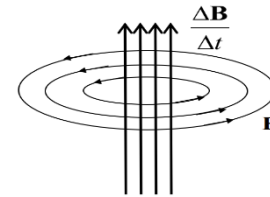
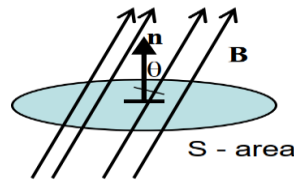

Note that F can be positive or negative, depending on the direction of B with respect to the unit vector n that is perpendicular to the loop. If B is perpendicular to the loop, the absolute value of F is maximal. If B is parallel to the loop, then F = 0.

Faraday's law: The EMF in a loop is equal to the rate of change of the magnetic flux

$$\mathcal{E} = - \frac{\Delta \Phi}{\Delta t}$$

through this loop

LENZ'S LAW 4-23

The direction of induced EMF and induced current is such that the magnetic field created by the induced current opposes the change in the magnetic flux.

in other words, the induced current tends to keep the original flux through the circuit from changing. As we shall see, this is a consequence of the law of Conservation of Energy.

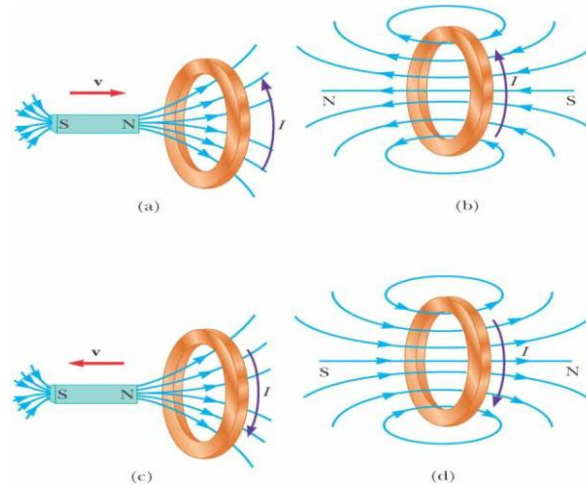

(a) When the magnet is moved toward the stationary conducting loop, a current is induced in the direction shown. (b) This induced current produces its own magnetic field directed to the left that counteracts the increasing external flux. (c) When the magnet is moved away from the stationary conducting loop, a current is induced in the direction shown. (d) This induced current produces a magnetic field directed to the right and so counteracts the decreasing external flux.

1-Electromechanics:

It focuses on the interaction of electrical and mechanical systems as a whole and how the two systems interact with each other. This process is especially prominent in systems such as those of DC Machines which can be designed and operated to generate power from a mechanical process (generator) or used to power a mechanical effect (motor).

Rectification:

Portable electronic devices such as radios and compact disc players are often powered by direct current supplied by batteries. Many devices come with AC–DC converters such as that shown in Figure 33.20. Such a converter contains a transformer that steps the voltage down from 120 V to, typically, 9 V and a circuit that converts alternating current to direct current. The AC–DC converting process is called rectification, and the converting device is called a rectifier.

Figure 1. The primary winding in this transformer is directly attached to the prongs of the plug. The secondary winding is connected to the power cord on the right, which runs to an electronic device. Many of these power-supply transformers also convert alternating current to direct current.

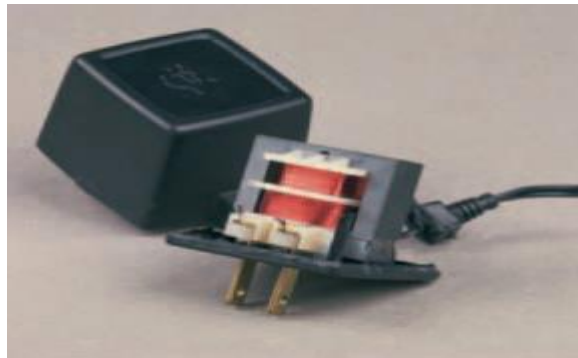

The most important element in a rectifier circuit is a diode, a circuit element that conducts current in one direction but not the other. Most diodes used in modern electronics are semiconductor devices. The circuit symbol for a diode is $\rightarrow|$ where the arrow indicates the direction of the current in the diode. A diode has low resistance to current in one direction (the direction of the arrow) and high resistance to current in the opposite direction. To understand how a diode rectifies a current,

consider Figure 2a, which shows a diode and a resistor connected to the secondary of a transformer. The transformer reduces the voltage from 120-V AC to the lower voltage that is needed for the device having a resistance R (the load resistance). Because the diode conducts current in only one direction, the alternating current in the load resistor is reduced to the form shown by the solid curve in Figure 2b. The diode conducts current only when the side of the symbol containing the arrowhead has a positive potential relative to the other side. In this situation, the diode acts as a half-wave rectifier because current is present in the circuit only during half of each cycle.

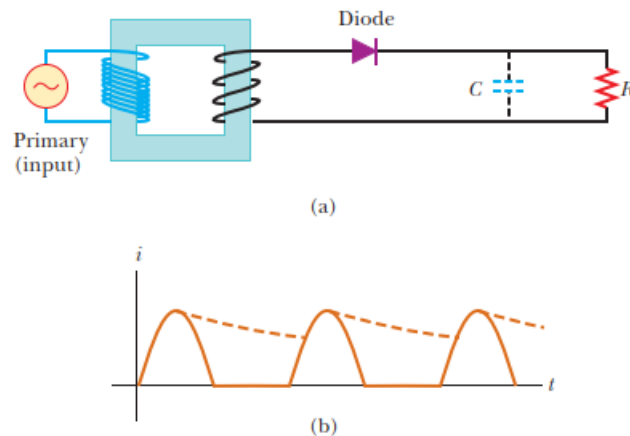

(a) A half-wave rectifier with an optional filter capacitor. (b) Current versus time in the resistor. The solid curve represents the current with no filter capacitor, and the dashed curve is the current when the circuit includes the capacitor.

- Converting ac to dc is accomplished by the process of rectification and two types of electro-medical apparatus are diode valve and the metal rectifier .
- Two processes are used:
 - Half-wave rectification;
 - Full-wave rectification.

2-Half-wave rectification:

A half wave rectifier is a type of rectifier which allows only half cycle (either positive half cycle or negative half cycle) of the input AC signal while the another half cycle is blocked.

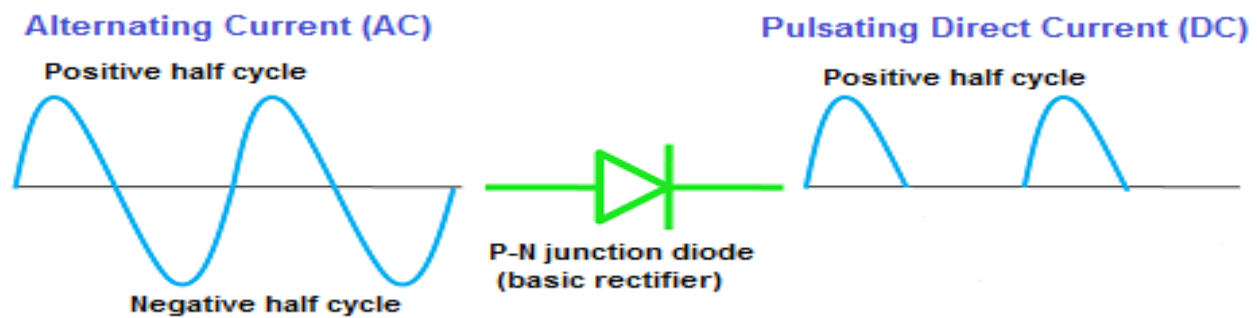

- The half wave rectifier is the simplest form of the rectifier. We use only a single diode to construct the half wave rectifier.
- The half wave rectifier is made up of an AC source, transformer (step-down), diode, and resistor(load). The diode is placed between the transformer and resistor (load).

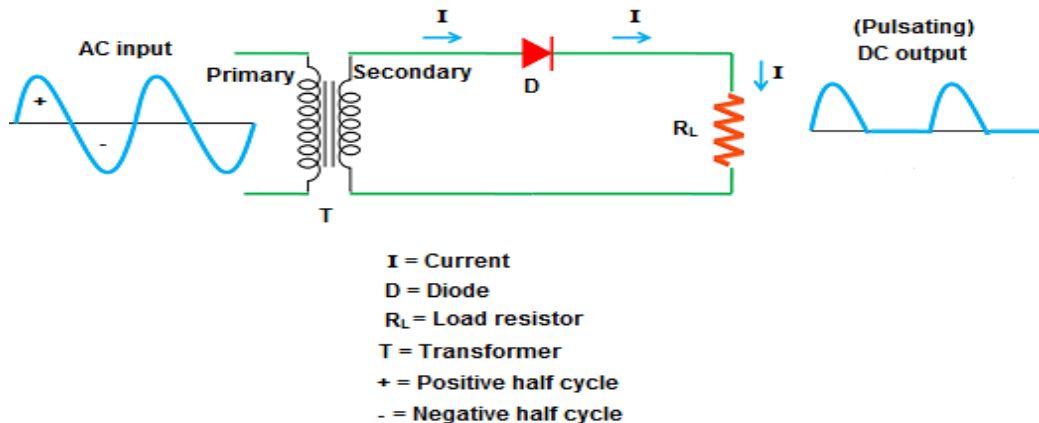

Half wave rectifier

3-Low frequency currents:

Currents with a frequency less than 10.000 per second are low frequency currents

low frequency include :

1. Faradic current,
2. Sinusoidal current,
3. High voltage galvanic stimulation,
4. Diadynamic currents.

Faradic current

- The faradic current is an interrupted alternating current with a frequency of 50-100 cycles per second (Hz) and a pulse duration of 0.1- 1 ms
- Faradic current is always surged for ttt purposes to produce a near normal tetanic like contraction and relaxation of the muscle.
- Surged current means gradual increase and decrease of peak intensity

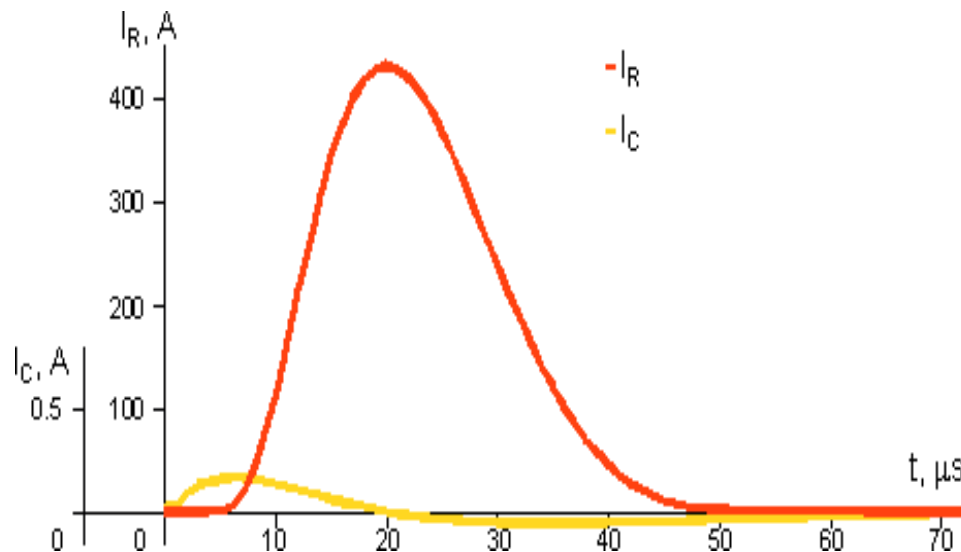

Production of the faradic current

Faradic current can be produced either from:

A. Faradic coil or smart Bristow coil

B. Thermionic apparatus

A. Faradic coil (Smart Bristow coil)

- It is a portable apparatus in which a dry battery is placed to supply the apparatus with a galvanic current which is transformed in the apparatus to a faradic current for the patient.
- Recent types of Bristow coils can be worked with all sorts of currents (AC, DC, or from the battery)

B. The thermionic apparatus

- It is a modern apparatus for the production of faradic current do not contain a faradic coil.
- The faradic current is produced through a thermionic grid glow tube which works smoothly and produce no noise while in action.

Effect of faradic current

1. Stimulation of motor nerves and muscles whose nerve supply is intact producing tetanic contraction as long as the current is passing and relaxed only when the current is off.
2. Stimulation of sensory nerves in the skin producing dilatation of the blood vessels in the skin

Clinical uses of faradic current

1. Electrodiagnosis; through stimulation of muscle whose nerve supply is intact.
2. Treatment of weak and atrophied muscles whose nerve supply is intact, e.g. disuse atrophy of muscles after prolonged casting.

3. Hysterical and functional conditions, e.g. hysterical paralysis, dysarthria, aphonia by vigorous stimulation of the diseased part with faradic shocks.

Another uses of faradic current

Some times , faradic current is used in the following conditions:

4. Constipation by applying faradic current to the abdominal wall over the colon which stimulates peristaltic movements reflexively.
5. Effusion of the knee by applying faradic current to the quadriceps muscle.
6. Muscle injuries and fibrositis to improve local circulation and prevent formation of adhesions.
7. Persistent limp edema
8. Infantile uterus to stimulate uterine musculature, this is accompanied by hormonal therapy.

Contraindication of faradic current application

1. Unreliable patients
2. Loss of sensations
3. Cardiac pacemaker
4. Superficial metals
5. Acute inflammation
6. Cancer
7. Thrombosis
8. Infection (TB)
9. Skin lesions → collection of current → pain and discomfort

Sinusoidal current

- It is an alternating current with a frequency of 50 cycles per second (Hz) and a pulse duration of 10 ms

- It is called sinusoidal because the shape of the wave is sine wave (S-shaped)

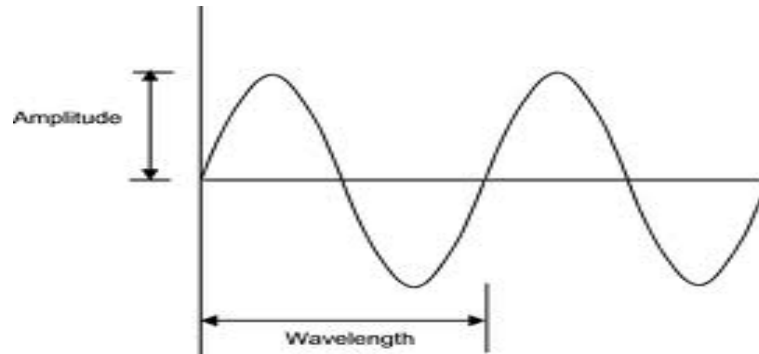

Production of sinusoidal current

1-It can be produced from the A.C. mains by a step-down transformer to diminish its voltage.

2-Also, it can be produced from motor generators.

Effect of sinusoidal current

- It is similar in its effects in almost every respect to the faradic current.
- However, it differs from the faradic current in that:
 1. It has a more marked stimulation of sensory nerve endings in the skin → a more marked improvement of circulation both locally and generally.
 2. Also, it is a more painful, because the time of stimulation is longer.

Clinical uses of sinusoidal current

- The same as faradic current.

•

3-HIGH VOLTAGE GALVANIC STIMULATION

(H.V.G)

High voltage galvanic generators produce:

-
1. High voltage current of 300- 400 milliamperes and a very short duration ranging between 50- 100 microseconds.
 2. They are penetrating deeper than those of low voltage current
 3. Direct stimulation of deep nerves and muscles can be effective
 4. Short duration of the pulse is comfortable to the patient.
 5. It will not produce contraction of denervated muscles as the pulse duration is too short to depolarize the muscle membrane.
 6. Partially innervated or totally innervated muscles will respond well to high voltage galvanic

Physiological effects of HVG

1. Pain reduction by stimulating the release of opiate substance β endorphin in the CNS to suppress pain.
2. \uparrow Joint mobility \rightarrow relief of ms spasm as a result of pain reduction + direct effect on blood vessels \rightarrow \uparrow circulation.
3. Enhancement of peripheral circulation by stimulation of muscle pumping effect on the venous circulation and stimulation of sympathetic neurons directly causing vasodilatation.
4. Reduction of post traumatic edema.

The Radiation

Radiation- Energy emitted from a body or source that is transmitted through an intervening medium or space and absorbed by another body. Transmission is in the form of waves but wave/particle duality under quantum physics.

Radiation is classified as being **either non-ionizing or ionizing**. Non-ionizing radiation is longer

wavelength/lower frequency lower energy. While ionizing radiation is short wavelength/high frequency higher energy.

Ionizing Radiation has sufficient energy to produce ions in matter at the molecular level. If that matter is a human significant damage can result including damage to DNA and denaturation of proteins. This is not to say that non-ionizing radiation can't cause injury to humans but the injury is generally limited to thermal damage i.e. burns.

Types of Non-Ionizing Radiation and Their Clinical Effects- Referring again to the chart above we can see that Non-Ionizing radiation comes in the forms of:

1. ELF (extremely low frequency)
2. Radio Frequencies
3. Microwave Frequencies
4. Lasers
5. Infrared
6. Visible Spectrum
7. Ultraviolet

Effect of ionized and non ionized radiation

Radiation exists in two main forms:

- Electromagnetic (EM) radiation in the form of alternating electric and magnetic waves that propagate energy,
- particle radiation consisting of accelerated particles such as electrons and protons.

EM radiation can be broadly categorised as non-ionising and ionising. Both types may be encountered clinically or environmentally, with exposure having potentially positive or negative effects on tissues and organisms ([Table 1](#)). In the case of non-ionising radiation, exposure of skin to ultraviolet radiation (UVR), for example, may be beneficial, as a consequence of vitamin D production, or detrimental, due photoageing and/or photocarcinogenesis. UVR is considered non-ionising as it is, in general, not sufficiently energetic to remove electrons from biomolecules. In contrast, energetic, ionising electromagnetic radiation (X-rays and gamma rays) can remove electrons. The undoubted importance of controlled exposure to ionising EM radiation in medical diagnostic imaging . and radiotherapy . must be balanced against side effects such as secondary cancers or tissue fibrosis . Other forms of radiation, which rely on charged particles (e.g., α , β , protons), can also interact with biological systems and are clinically important (such as in proton therapy and in cosmic radiation exposure for space exploration), but being non-electromagnetic, they lie outside the scope of this review. The reader is referred to an excellent review by Helm et al. .

Electromagnetic Radiation

UVR and X-rays/Gamma rays, both being part of the EM radiation spectrum, differ only in wavelength, frequency and energy. When a molecule absorbs EM radiation, it undergoes one of three possible transitions: electronic, vibrational, or rotational . In general, electronic transitions require the largest amount of energy, followed by vibrational then rotational

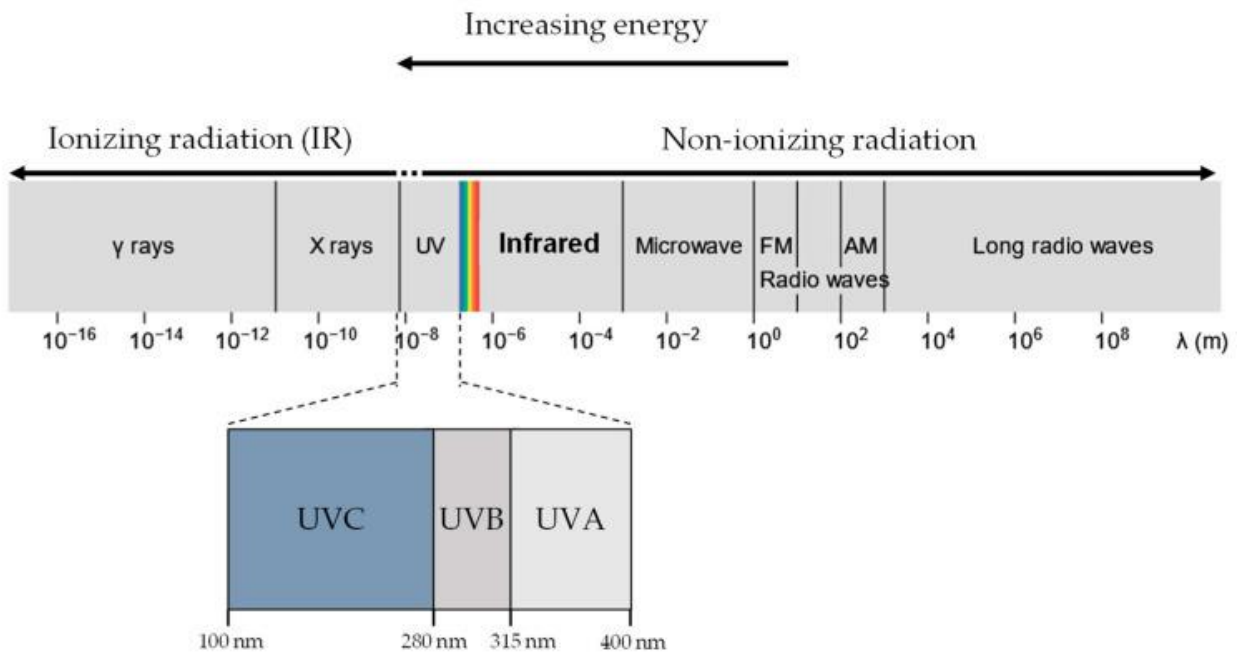

The Heat

- Temperature is how hot or cold something is. Temperature is really a measure of how fast the atoms and molecules that make up a substance are moving (this movement is sub-microscopic; you cannot see it).
- A thermometer measures the temperature of something, showing how hot or cold it is.
- There are many different types of thermometers that measure the temperature of different things. We use thermometers to measure the temperature of the air, our bodies, food, and many other things. There are analog and digital thermometers. An analog thermometer shows the temperature on a scale or dial; a digital thermometer shows the temperature as a number.
- The higher the number above zero, the higher the temperature.

Temperature Conversion Formulas:

Change Equation

Select an equation to solve for a different unknown

$t_C = \frac{5}{9}(t_F - 32)$	Convert Fahrenheit to Celsius
$t_F = \frac{9}{5}t_C + 32$	Convert Celsius to Fahrenheit
$t_K = t_C + 273.15$	Convert Celsius to Kelvin
$t_C = t_K - 273.15$	Convert Kelvin to Celsius

Conversion Formulas

If you know the temperature in one temperature scale you can use a formula to figure out what it is equivalent to in other scales. The conversion formulas are in the table that follows.

Celsius to Fahrenheit (and Fahrenheit to Celsius):	Kelvin to Celsius (and Celsius to Kelvin):
$F = 1.8C + 32$	$C = K - 273$
$C = (F - 32)/1.8$	$K = C + 273$
(A degree Celsius is 1.8 times bigger than one degree Fahrenheit.)	(Converting between Celsius and Kelvin is easy because the size of a degree Celsius is the same as the size of a kelvin.)

Safety in biomedical instruments

Danger to patients

In a clinical environment patient is exposed to various risks, more than a typical workplace or at home

-frequent invasive (blood) operations - penetration through skin or mucous membranes

– presence of potentially hazardous chemicals and substances - anesthetics, medicines, medical gases

– sources of infection - particularly "hospital infection"

– various sources of energy that penetrate into or through the patient: current, voltage, ionizing and non-ionizing radiation, sound and ultrasound, electric and magnetic field, UV radiation, lasers, microwave radiation, mechanical stress, etc.

Physiological effects of electricity

- Body (tissue) becoming a part of an electrical circuit
- The amount (amplitude) of electricity often depends on the ratio of voltage present and the sum of all (serially connected) impedance
- Usually, the highest impedance is the impedance of the skin
- The consequence of current flow:
 - nerve and/or muscle tissue stimulation
 - heating of tissues (a result of tissue resistance)
 - burns

Consequences of dangerous voltage

- Consequences depend on the voltage – current relation, but also on individual susceptibility
- Expected values
 - Intact skin, $RK = 2-5 \text{ k}\Omega$
 - Damaged skin - injuries, surgical procedures, $RO = 100 \Omega - 1 \text{ k}\Omega$
- Focus on the worst possible scenario, for example, a person holding two conductors at different potentials in his hands □ resulting muscle spasms, inability to release captured conductors
- In case of intact skin, $RK = 2-5 \text{ k}\Omega$, cramps can occur even at a voltage of few dozen mA
- In case of damaged skin - injuries, surgical procedures, $RO = 100 \Omega - 1 \text{ k}\Omega$, fibrillation may occur at voltages of several volts and current of few dozen mA

Safe voltages - AC

- Security measures in designing
 - defining voltage values that may **not appear on the conductive parts of instruments or equipment** coming into contact with the patients skin or user
 - for **alternating** current:
 - safety extra low voltage, SELV of 50V, 50/60Hz
 - medical safety extra low voltage, MSELV of 25V, 50/60Hz



Safe voltages - DC

- Security measures in designing
 - defining voltage values that may **not appear on the conductive parts of instruments or equipment** coming into contact with the patients skin or user
 - for **direct** current:
 - safety extra low voltage, SELV of 120V,
 - medical safety extra low voltage, MSELV of 60V, 50/60Hz



Microshock vs. macroshock

- The consequences of current passage through the tissue depend on the contact point with the source of voltage

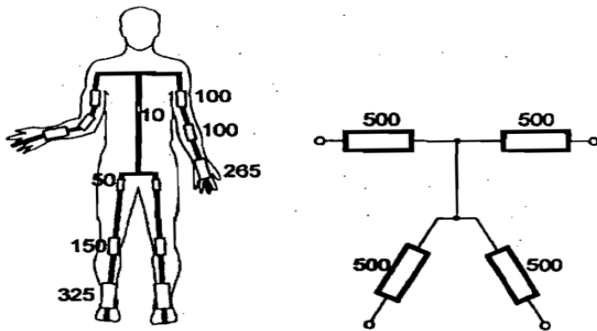
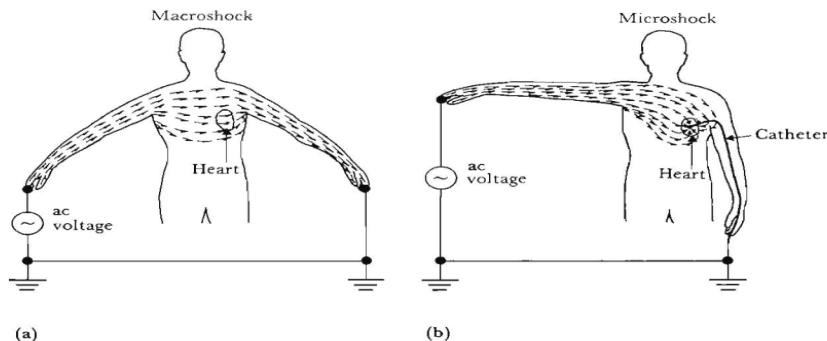

Figure 4.7. Distribution of internal body resistance and a simplified equivalent diagram.

Even greater power will not necessarily cause fatal consequences, eg. fibrillation, when going through the limbs



Microshock vs. macroshock



- Macroshock is caused by current passing through the body through the skin, and the current that can cause harmful effects is relatively high and significantly depends on the point of contact
- Microshock is caused by the passage of relatively low current, but the source of electricity was brought directly into contact with the heart, for example, during cardiac catheterization (catheter in the heart is a diagnostic procedure). Electricity sufficient to induce fibrillation is of $n \times 10\mu\text{A}$. Another point of contact can be anywhere on the body (eg limbs). Current of $10\mu\text{A}$ is considered safe limit to prevent microshock