



**College of Health and Medical
Technologies - Al-Dour
Department of Optics Technologies
The second stage**

Refractive

Ass.Lec .Haider Sobhi Faisal

الجامعة التقنية الشمالية
NORTHERN TECHNICAL UNIVERSITY



Light is electromagnetic radiation visible to the human eye, responsible for the sense of sight. The wavelength of light ranges from 400 nanometers (nm) to 700 nanometers - between infrared (longer waves) and ultraviolet (shorter waves) These figures do not represent the absolute limits of human vision, but represent the approximate range that most people can see well in most conditions. The wavelengths of different sources of visible light are estimated from the narrow band (420 to 680) to the range Under ideal conditions, humans can see at least infrared radiation with a wavelength of 1050 nm and children and young adults can see ultraviolet between about 310 to 313 nm. The basic properties of visible light are intensity, direction of propagation, frequency or wavelength, spectrum, and polarization, while its speed in vacuum, estimated at (299,792,458 m/s), is one of the basic constants in nature.

What all types of electromagnetic radiation (EMR) have in common is that visible light is emitted and absorbed in the form of small beams called **photons** that can be studied as particles or waves. This property is called particle **wave-duality**. The study of light is known as optics, and is an important field of research in modern physics.

During the 19th century, scientists thought that light was a wave that travels like a water wave. The wave theory of light became popular because it enabled scientists to explain the phenomenon of interference pattern, which

are bright and dark lines that scientists obtained from light experiments. And if light is a wave, what are these waves? Water waves are easy to interpret because they travel through the surface of the water while the water itself moves up and down. For 19th-century scientists, light looked different from water waves because of its travel in space from the sun and other stars to Earth, assuming that light waves should travel through matter just as water waves travel through water. Scientists called the substance ether, although they could not find proof of the substance's existence. By the end of the 19th century, scientists had determined that light waves consisted of regions known as electric fields and magnetic fields.

The simple model of a light wave begins with a ray (straight line) showing the direction of transmission of light. The short arrows along the beam, perpendicular (right angles) to it, represent the electric field. Some arrows point up from the beam and others point down. They vary in length, so the overall pattern of arrowheads is wave-like and arrows representing the magnetic field are also wave-like, but these arrows make a right angle with arrows representing the electric field. This pattern moves through the beam, which is light. Experiments at the beginning of the 20th century proved that scientists eventually left the idea of ether. They realized that a light wave, as a regular pattern of electric and magnetic fields, can travel through space.

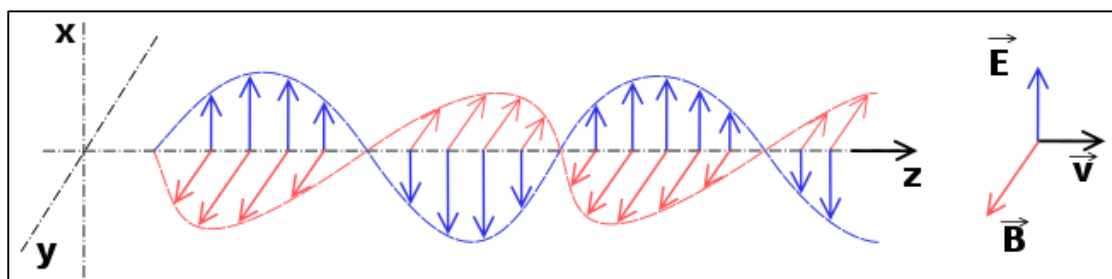

An electromagnetic wave is generally characterized by the following factors:

- ❖ **Wavelength (λ):** The distance of a straight line from the peak of the wave to the peak after it.
- ❖ **Frequency (f):** The number of times the peak passes from a fixed point per second.
- ❖ **Amplitude (A):** It is the maximum distance of the top or bottom (the lower point of the beam).
- ❖ **Interval (T):** It is the time required for the passage of two peaks or troughs through a fixed point in space.
- ❖ **Propagation speed:** The distance traveled by a wave in a time of one second during its propagation.

To calculate the speed of propagation of light (c) in a vacuum:

$$f = \frac{c}{\lambda}$$

$$c = f \cdot \lambda$$

$$\text{OR } c = \frac{\lambda}{T}$$

Stage of Discovery of light

مراحل اكتشاف الضوء

- ❖ **The following are the stages of light detection:**

1-Pre-nineteenth century in ancient times

Before the nineteenth century, light was thought of as a torrent of particles that either emanate from the eye, or from the object we are looking at. He led the idea that light is particles emanating from objects we see by the scientist Isaac Newton, and used this idea to explain the phenomena of reflection and refraction..

2-The wave theory of Huygens remained accepted by scientists for Newton's assumption of the master of the situation until 1678 AD, when the Dutch physicist and astronomer Christian Huygens suggested that light is a type of wave, and the wave theory of Huygens was able to explain the phenomena of reflection and refraction of light.

3-Thomas proved the wave theory

In 1801, Thomas Young was able to prove that light is a wave, by making light interfere, which will lead to a decrease in the intensity of the light (or its complete disappearance), or an increase in the intensity of the light (or double its intensity) These two phenomena are known as destructive interference and constructive interference respectively. Maxwell (Maxwell) published his work on electricity and magnetism in 1873 which also supported the wave theory of light.

4-Einstein's proof of the photoelectric phenomenon

The wave theory of light was able to explain most light phenomena, but it failed to explain some phenomena, such as: Photoelectric Effect, the

phenomenon through which we see an electron emitting from the surface of the metal when light is shining on it, and the failure of the wave theory of light lies in the fact that the kinetic energy of each electron does not depend on the intensity of the incident light, but on its frequency, while the number of electrons emitted from the surface of the metal depends on the intensity of the light falling on this. The famous scientist Albert Einstein was able to explain this phenomenon in 1905 using the concept of quantization of energy developed by the scientist Max Planck, and as a result of his explanation of this phenomenon, he won the Nobel Prize in Physics in 1921, but he received it in 1922. To answer what light is, it can be said that light sometimes exhibits wave behavior, and at other times shows object-specific behavior.

The Photon الفوتون

In 1905, the German physicist Albert Einstein proposed a model of light, which is just as useful as the wave model. In some experiments, light behaves as if it were particles, and this type of particle is now called photons. In Einstein's model, the light ray is the path taken by the photon. For example, when a lamp sends a ray of light through a dark room, the light beam consists of a large number of photons, each of which travels in a straight line. So is light waves or particles? Apparently, the two models cannot be together, because the two models are completely different. And the best answer is that light is neither. In some experiments, light behaves as if it were a wave, and in others it behaves as if it were particles. Light in

a vacuum has the same speed, unlike other types of waves, which is the maximum possible speed of anything. Scientists do not understand what this fact is. The fact that light in a vacuum has a single velocity is one of the foundations of Einstein's theory of relativity..

When light enters a substance, it hits atoms that disrupt its course, but it travels at its usual speed from one atom to another.

الطيف المرئي والكهرومغناطيسي

Electromagnetic spectrum The electromagnetic spectrum is the total range of electromagnetic radiation at all frequencies. The "electromagnetic spectrum" (usually called only spectrum) emitted to an object is the characteristic distribution of electromagnetic radiation from that object.

The electromagnetic spectrum extends from the first low frequencies, such as the frequencies used in radio (at the end of the long wavelength), across medium frequencies, such as the frequencies of light rays, to high frequencies, such as X-rays and ends, with various gamma rays (at the end of the very short wavelength). It covers in its range from the first wavelengths estimated at thousands of kilometers to wavelengths the size of an atom and even smaller. The short wavelength limit is considered to be close to Planck's length, and the long wavelength limit is the size of the entire universe. (Watch Natural Space Science),

The spectrum is the general representation of electromagnetic waves. In scientific research, we are usually interested in the spectra of elements, where each element is characterized by a distinctive spectrum such as the fingerprint in people, and appears in the form of adjacent parallel light lines

of different distinctive colors. The spectrum is located in the visible field of the electromagnetic spectrum, between red light and has a wavelength of about 700 nm and violet light and has a wavelength of 400 nm.

The electromagnetic spectrum consists of waves:

1. Microwave
2. radio
3. Terrahertz
4. Infrared
5. Visible
6. spectrum Ultraviolet
7. X-ray
8. Gamma rays

These major groups include other secondary subgroups. The electromagnetic spectrum is made up of groups of waves with the same characteristics but differs in their wavelengths and frequencies. Wireless groups.

1. Infrared.
2. Visible spectrum waves.
3. Ultraviolet waves.
4. X-ray waves.
5. Gamma ray waves.

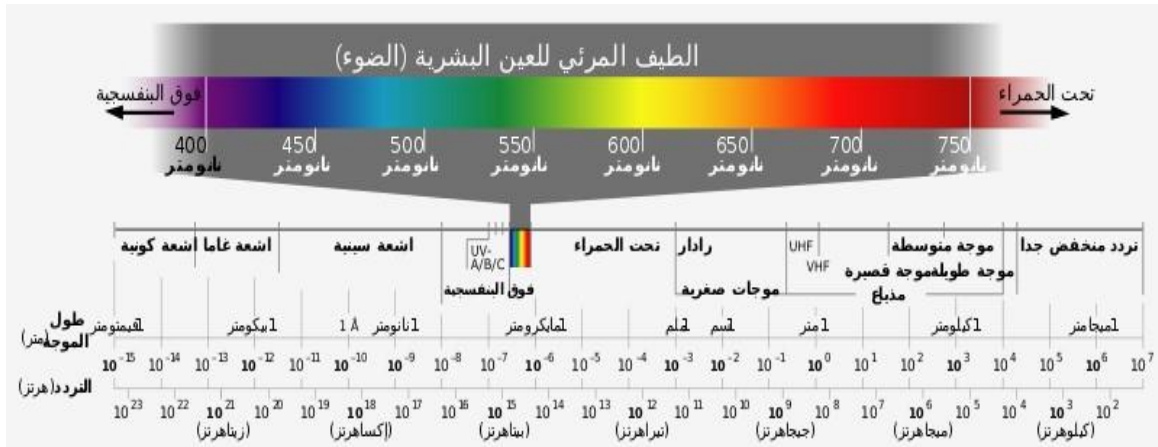

This range of the electromagnetic wave spectrum can be defined as the spectrum that can affect the eye so that it can see it, and the visible light spectrum begins at violet and ends at red. Because the sensitivity of the eye varies depending on the wavelength of the light rays received, it is able to distinguish between different colors. Eye sensitivity is greatest at the wavelength between green and yellow. Light wavelengths are measured in very small units such as micrometers, nanometers and angstroms.

The difference in wavelength can be observed in the eye and then translated inside the mind to the color of red, which has the longest wavelength, as its wavelength is 700 nm, and violet has the shortest wavelength, as its wavelength is about 400 nm, and between them there are various colors such as orange, green, and blue. The wavelength of the electromagnetic spectrum outside the field of view of the eye is called ultraviolet and infrared. Some animals, such as bees, can see some long wavelengths. Prolonged exposure of the skin to UV rays can cause sunburn or skin cancer, and lack of exposure causes vitamin D deficiency.

Methods for measuring the speed of light طرق قياس سرعة الضوء

Although the light seems to travel through the room the moment the window curtain is lifted, it actually takes some time to travel any distance. The speed of light during a vacuum where atoms do not disrupt its transmission is 299,792,458 m/s (approximately 186,282 m/s). All forms of electromagnetic radiation move at the same speed in a vacuum.

Astronomers have believed that light travels infinitely, and any event that occurs anywhere in the universe was observed at all other points in the universe at the same time

1- Galileo's attempt to measure the speed of light using lanterns

In the early 17th century, Galileo designed his experiment to measure the speed of light to make it happen. Galileo sent one of the assistants to a distant plateau with instructions to open the cover of a lantern that he carries when he watches Galileo on another plateau open the cover of his lantern, and Galileo's goal was that by knowing the distance between the two plateaus, he could calculate the speed of light by measuring the time between the moment he opened the lid and the moment he saw the light of the second lantern, and the experiment failed even though Galileo's thinking was reasonable. Because the speed of light is so high, he couldn't calculate the short time.

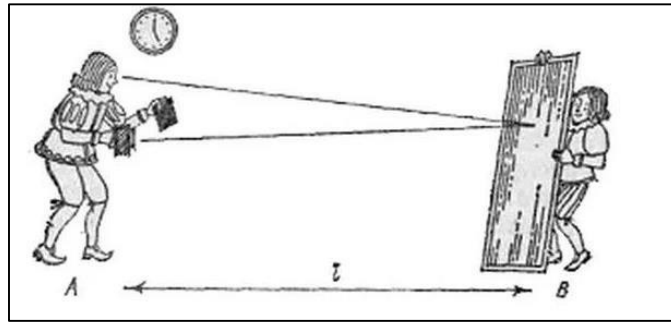

2-Romer's method by Jupiter's satellites

In 1675, the Danish astronomer Romer attempted to measure the orbit of Io, Jupiter's third-largest moon, by watching how long it takes to pass around the planet. After observing it from the Earth's surface for many years, Romer discovered something amazing:

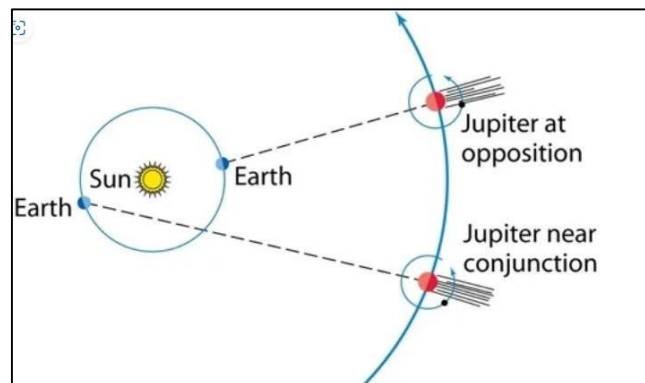

Romer observed that the interval between successive lunar eclipses became steadily shorter when periodically observed from the Earth's surface. This was explained as due to the difference in the distance between Earth and Jupiter, as the Earth moved in its orbit towards Jupiter and became steadily longer as the Earth moved away from Jupiter. From his data for the accumulation of these differences, Romer estimated that when the Earth is closer to Jupiter, the Io eclipse will occur approximately 11 minutes earlier than expected based on the average of Jupiter's orbital period over many

years. After 6.5 months, when Earth moves in orbit and away from Jupiter, the eclipse occurs 11 minutes later than expected.

Romer estimated that light needed twenty-two minutes (1320 seconds) to cross the diameter of Earth's orbit. The speed of light can then be known by dividing the diameter of the Earth's orbit by the time difference. Romer received a value of 214,000 km / s compared to the current value of 299.792 km / s. The exact diameter of Earth's orbit was not known and there was also an error in measuring the delay. However, this was the first confirmation that the speed of light is limited.

3 -Vizo method by rotating sprocket

This method also depends on the relationship between distance, speed and time, but how can time be calculated at this tremendous speed, and this was Fizeo's idea to know the time of light reaching one of the points accurately, and through that the speed can be calculated.

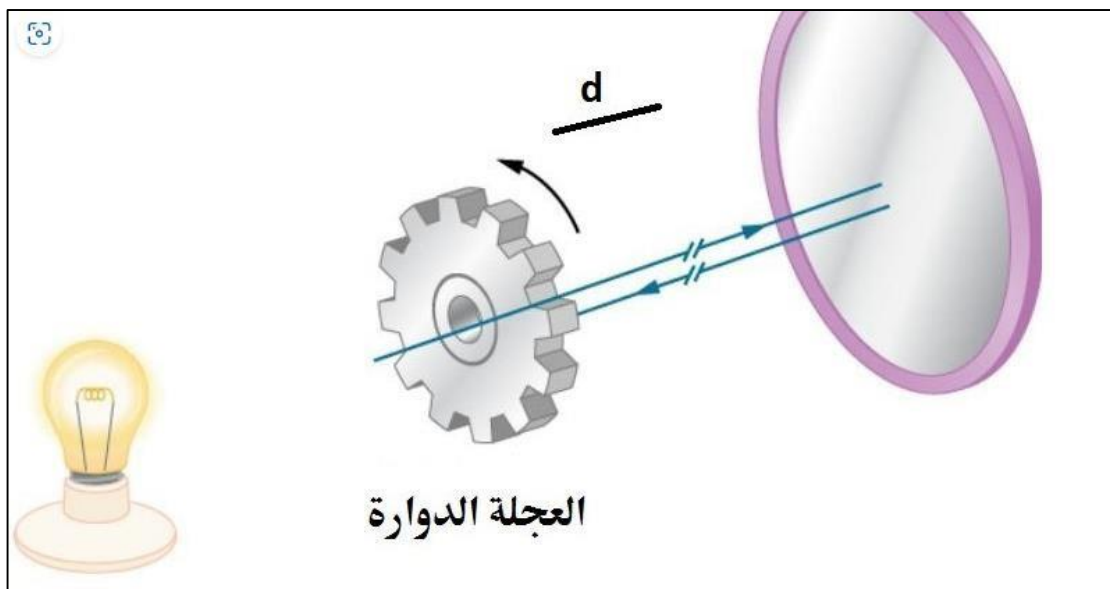

Vizo built a device to try to measure the speed of light in which a toothwheel and a mirror were placed eight kilometers away, and then sent focused pulses of light between them. It made light pass from one of the tooth holes to the mirror to reflect again and pass through the same opening to reflect on another mirror that was placed behind the wheel.

When the wheel rotates very quickly, so that the light beam passes from one of the tooth holes to fall on the far mirror, but when it returns it collides with one of the gears, then the light traveled a distance of 16 km in a time of t , which can be calculated by knowing the number of teeth, wheel speed and distance between each tooth, thus Fizeau was able to calculate the speed of light. It received a value of 313,300 kilometers per second. Although it is about 5% higher than the true amount, it is the most accurate way to measure the speed of light.

4- Leon Foucault method

In 1862, Leon Foucault conducted an experiment using rotating mirrors to determine the speed of light and the result was approximately 298,000,000 m/s

5- Albert Mickelson method

In 1926, American physicist Albert Mickelson replicated the Foucault method using advanced rotating mirrors to measure the time required for light to complete a round trip from Mount Wilson to Mount San Antonio, California. Accurate measurements resulted in a speed of

light of 299,796,000 m/s, with a possible error of less than four kilometers per second.

Properties of Light

خواص الضوء

1- الانكسار The Refraction

Refraction changes the direction of a wave's path when it travels from one medium of one substance to another medium. Waves are refracted (bent) when they travel at an angle from one medium to another where the speed of light is different. In fact, the straw placed inside a glass with water appears to be broken at the surface of the water. Because the speed of light in water is lower than in air. The magnitude of flexion of a ray of a certain wavelength, as it travels from one medium to another, is determined by the law of refraction (Snell's law) between the mediums of that wavelength. The law of refraction is found by trigonometry. It is a sinusoidal function of the angles of incidence and refraction:

$$n_1 \sin \theta_1 = n_2 \sin \theta_2$$

حيث أن n_1 و n_2 هي الزاوية بين الشعع وسط واعع ا ال، اعع ا و θ_1 و θ_2 هي الزاوية بين الشعع وسط واعع ا ال، اعع ا و n_1 و n_2 هي الزاوية بين الشعع وسط واعع ا ال، اعع ا و $n_1 < 1$ في الفراغ و $n_2 > 1$ في المسدة الشفسفة.

Most laws of refraction depend on the relationship between the angle of a ray in air and its angle in a medium such as glass, quartz, or plastic. Different colors of light are not refracted to the same degree because they have different wavelengths and a constant frequency. Because of this optical property, light rays decompose into the seven colors of the spectrum. The publication operates on the basis of this principle. The refractive function of the lenses is used to process light in order to change the size and clarity of images. Examples include magnifying lenses, glasses, contact lenses, microscopes and refractive telescopes.

The Interference 2- التداخل

Light in most cases is defined as waves each with a top and bottom. When two light waves pass through the same point, they overlap each other, so they combine or subtract from each other. Suppose that whenever one wave's peak passes through a point, it simultaneously passes the peak of another wave. The two summits come together to give a grand summit. This process is called constructive interference, and it gives more bright light than any single wave. If we assume instead that whenever there is a wave peak passing through the point and there is a bottom for another wave passing through it, the bottom will reduce the height of the top and leave the point dark or dark. This process is called destructive interference.

The existence of interference phenomena that results in the brightness or dimming of light is one of the strongest arguments in support of the wave theory of light. All types of waves produce patterns of constructive and

destructive interference when they pass through two small adjacent openings.

At the beginning of the 19th century, the English scientist Thomas Young demonstrated in his famous experiment the wave nature of light by sending a ray of light through two narrow openings. The light that comes out of the openings reaches a screen. If the nature of the light is non-wave, it appears on the screen as two narrow bright spots, each of which comes out of an opening, but the reality is that when the light comes out of each opening, it propagates with the other light, and the screen is filled with bright and dark lines called cilia. Shiny cilia form when the two waves reach a peak with a peak to give a constructive overlap. Opaque cilia form when the waves reach a peak with a bottom to give a destructive overlap.

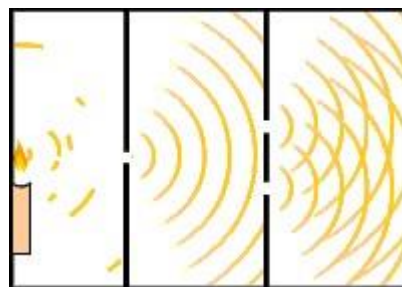

3- الحيود والانتشار Diffraction and Diffusion

One of the most obvious characteristics to the naked eye is light propagating in a straight line, and this type of diffusion is called diffraction. Diffraction as in interference is the result of the fact that light behaves like a wave. The light wave propagates slightly when it travels through a small

hole, around a small particle, or through an edge. Water waves also propagate, but the vents and objects that cause propagation must be larger than those in the case of light. Light diffraction can be annoying. Suppose you try to see a very small particle with a highly efficient microscope. The greater the magnification ability to see the object up close, the blurred the edges of the body appear. Each blurred edge is caused by the fact that light is refracted when it passes through the edge on its way to the eye.

Diffraction, on the other hand, serves to study the colors of the light beam if we use a device called a diffraction groove. The grooved has thousands of thin openings that give us light. Each color in the light is neutralized by a slightly different amount, and the spread of colors so large makes it possible to see each color. The diffraction groover is used in telescopes that separate colors in light from stars, enabling scientists to study the materials that make up stars.

Reflection and Scattering 4- الانعكاس والتشتت

When light hits an object, the material of that object retains energy and then re-emits it in all directions, a phenomenon called reflection. However, visually smooth surfaces due to destructive interference lose most of the rays, except that they spread at the same angle that had the effect. Examples of this effect are mirrors, polished surfaces such as chrome, and river water (because their bottom is dark).

Polarization 5- الاستقطاب

The polarization phenomenon can be observed in a transparent crystal placed parallel to another and one rotated at an angle of 90° , through which light cannot pass. Polarized light can be obtained through light reflection. And the partially or completely reflected light is polarized with an angle of incidence. The angle that causes total polarization is called the Brewster angle or polarization angle. Many sunglasses and camera filters contain polarizing crystals to eliminate annoying reflections.



Department of Optics Techniques

Lecture Second

Mirrors

M.S.C. Hayder Sobhi AL-DOURY

Mirrors

Mirrors are reflective surfaces used to reflect light and form images. Mirrors can be made of a variety of materials, but the most common is glass coated with a thin layer of metal, such as silver or aluminum.

Types of mirrors

Plane mirrors are a type of mirror with a smooth, flat surface, and are the most common and widely used.

Features:

- **Smooth surface:** The surface is free of defects, allowing light to be reflected evenly.
- **Resulting images:** Produces real images of the same size and orientation, but flipped vertically.
- **Angle:** The angle of incidence on the mirror is equal to the angle of reflection.
- Easy to manufacture: They are produced at a low cost compared to other types of mirrors.
- Suitable for everyday applications **Uses :**

1. **Decoration:** Used in homes and offices to decorate walls and create a sense of spaciousness.
2. **Cosmetics:** Used in cosmetics and personal mirrors.
3. **Education:** Used in scientific experiments to illustrate the principles of reflection.

2- Concave mirrors

Concave mirrors are a type of mirror that has its reflecting surface concave inward, meaning that the reflecting part is directed toward the concave side. These mirrors have many properties and applications:

Features:

1. Image Formation: Concave mirrors can form real or virtual images, depending on the position of the object relative to the mirror.
2. Amplification And zoom in Image
3. Focusing light: Concave mirrors focus light rays to a specific point, making them useful in applications such as lamps or telescopes.

3- Convex mirrors

Definition of convex mirrors:

Convex mirrors are a type of mirror that has a convex outer surface, which causes it to reflect light in a certain way. These mirrors are typically used in applications that require a wide view or image magnification.

Features:

1. Image composition:

Convex mirrors produce virtual images.

- Images are always thumbnails and straight.

2. Viewing angle:

- Provides a wide field of view, making it ideal for use on car sidelights or in home mirrors.

Uses:

- Used in cars to provide better vision for the driver.
- Used in stores to monitor theft.
- Used in scientific applications such as microscopes.

Lenses

A lens is a transparent object that can be made of glass or plastic, and is used to modify the path of light. Lenses focus or disperse light rays, resulting in the formation of an image of objects.

Types of lenses

1-concave lenses

A concave lens is a type of lens that is thinner in the middle and thicker at the edges. These lenses are used to disperse or spread light rays, making them useful in a variety of applications.

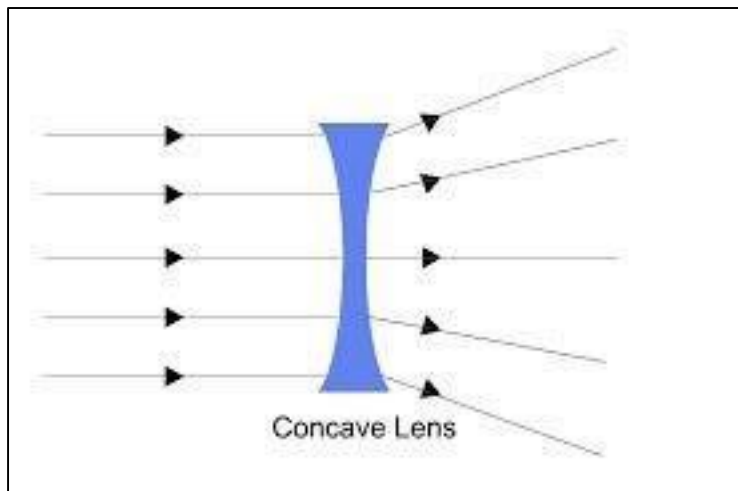

□ General properties of concave lens

- Lens shape: It is concave on both sides, which allows light to be dispersed.
- Focus: Parallel light rays passing through a concave lens appear to come from a virtual point known as the focus, which is on the same side of the lens as the light entering.

Focal length: the distance between the lens and the focus. And it is negative.

Mohammed Ghazi Kareem Mirrors and lens

- **uses of concave lens**

- In glasses: used to correct farsightedness (hyperopia) by scattering light to reach the retina properly.
- In cameras: Used in some types of cameras to correct optical distortions.
- In microscopes: used to magnify images in a certain way.

- **How to work concave lens:**

When light rays pass through a concave lens, the rays are refracted as they enter and exit, causing them to diverge. As a result, the rays appear to come from a virtual point behind the lens.

- **Other applications for concave lens.**

- Mirrors: Some types of mirrors are used for optical purposes.
- Optical devices: used in endoscopes and devices that require light dispersion.

Concave lenses play an important role in improving vision and facilitating many scientific and technical applications.

2-convex lens

It is a type of lens that is thicker in the middle and thinner at the edges. These lenses are used in many optical applications because of their ability to focus light rays.

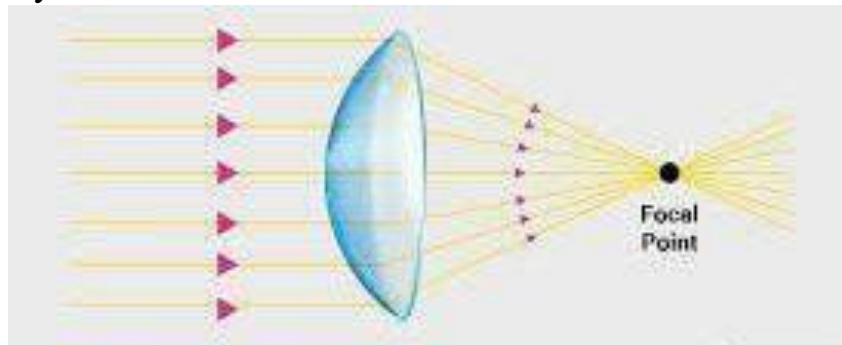

□ **General properties of convex lens:**

Lens shape: A convex lens is concave on both sides, allowing light to be focused.

- Focus: Parallel light rays passing through a convex lens are focused at a point known as the focus. This point is located on the other side of the lens.

Focal length: The distance between the lens and the focus is known as the focal length, and it can be positive.

A Uses of convex lens:

- In glasses: used to correct myopia (myopia) by focusing the image on the retina.

- In cameras: used to improve image quality by focusing light.

- In microscopes: used to magnify fine images of small objects.

• **How to work convex lens:**

When light rays pass through a convex lens, they are refracted as they enter and exit the lens, causing them to focus at the focal point.

• **Other applications for convex lens:**

- Binoculars: Binoculars are used to see distant objects clearly.

- Projectors: Used in projectors to improve image display.

The convex lens is an essential tool in many optical applications, enhancing our ability to see the world around us clearly.

calculate

1- General law of mirrors and lenses

$$\frac{1}{f} = \frac{1}{u} + \frac{1}{v}$$

Magnification power equals

$$M = \frac{\text{بعد الجسم}}{\text{بعد الصورة } u} = \frac{v}{u}$$

Definitions 1. Focus

The focus is the point where light rays converge after passing through a lens. In convex lenses, the focus is the point where parallel rays are focused, while in concave lenses, the rays appear to come from a virtual point also known as the focus.

2. Focal length

Focal length is the distance between the lens (or mirror) and the focus. It is usually expressed in units of length (such as millimeters or centimeters).

- In convex lenses, the focal length is positive, which means the focus is on the other side of the lens.
- In concave lenses, the focal length is negative, which means that the focus is on the same side of the lens that the light enters from.

3. Visual center

The optical center is the point in the middle of the lens where the principal axis of the lens intersects. Light rays passing through the optical center are unaffected, that is, they continue on their path without deviation. The optical center is an important reference point for determining lens properties, such as focal length.

Mohammed Ghazi Kareem Mirrors and lens

Object distance (u)	Ray diagram	Type of image	Image distance (v)	Uses
$u = \infty$		<ul style="list-style-type: none"> - inverted - real - diminished 	<ul style="list-style-type: none"> $v = f$ - opposite side of the lens 	<ul style="list-style-type: none"> - object lens of a telescope
$u > 2f$		<ul style="list-style-type: none"> - inverted - real - diminished 	<ul style="list-style-type: none"> $f < v < 2f$ - opposite side of the lens 	<ul style="list-style-type: none"> - camera - eye
$u = 2f$		<ul style="list-style-type: none"> - inverted - real - same size 	<ul style="list-style-type: none"> $v = 2f$ - opposite side of the lens 	<ul style="list-style-type: none"> - photocopier making same-sized copy
$f < u < 2f$		<ul style="list-style-type: none"> - inverted - real - magnified 	<ul style="list-style-type: none"> $v > 2f$ - opposite side of the lens 	<ul style="list-style-type: none"> - projector - photograph enlarger
$u = f$		<ul style="list-style-type: none"> - upright - virtual - magnified 	<ul style="list-style-type: none"> - image at infinity - same side of the lens 	<ul style="list-style-type: none"> - to produce a parallel beam of light, e.g. a spotlight
$u < f$		<ul style="list-style-type: none"> - upright - virtual - magnified 	<ul style="list-style-type: none"> - image is behind the object - same side of the lens 	<ul style="list-style-type: none"> - magnifying glass



Department of Optics Techniques

Lecture Third

Visual acuity

M.S.C. Hayder Sobhi AL-DOURY

Visual Acuity

Visual acuity refers to the ability to see details clearly. It is usually measured using a visual acuity meter, with a person having 20/20 visual acuity being considered able to see details that are considered normal at 20 feet.

There are several factors that affect visual acuity, including:

1. Eye health : such as the presence of diseases such as retinopathy.
2. Environmental pollutants such as dust, toxic gases, etc.
3. Lighting : Good lighting helps improve vision.
4. Focus : The ability to focus on objects near or far.

Snellen chart (A Snellen Chart is a tool used to test visual acuity. The chart usually consists of a set of letters or symbols that vary in size, and is used to determine how well a person can see detail.

Components of the diagram:

1. Letters or symbols: Contain English letters (such as "E") or other symbols.
2. Different sizes: Letters range from uppercase to lowercase.
3. Visual acuity scale: It is used to measure visual acuity using a system such as 6/60 or 20/20.

How to use it:

1. Distance: The person is asked to stand 6 meters (or 20 feet) away from the chart.
2. Reading: The person is asked to read the letters from top to bottom.
3. Determine acuity: The best row that can be read clearly is recorded. If the person can read a particular row, the visual acuity measurement is determined based on the size.

Interpretation of results:

- 6/60: This means that a person sees from 6 meters what a normal person can see from 60 meters (poor vision).
- 6/6: means normal vision.
- 6/5: means better than normal vision.

Visual acuity test chart using Snellen chart

1. Setup

- Make sure there is good lighting.
- Sit 20 feet (6 meters) away from the table.

2. Eye Cover

- Cover the right eye (use a cloth or hand).

3. Reading letters

- Start from the top line and read the letters.
- Scroll down to the smallest letters you can clearly see.

4. Recording Results

- Write the appropriate number (such as 20/20 or 20/40) based on the line you were able to read.

5. Repeat the process

- Repeat the steps with the left eye.

6. Consult a doctor

- If you have any problems or questions, consult your eye doctor.

comments

- Make sure you are not wearing contact lenses or glasses if you want to measure your visual acuity without them.

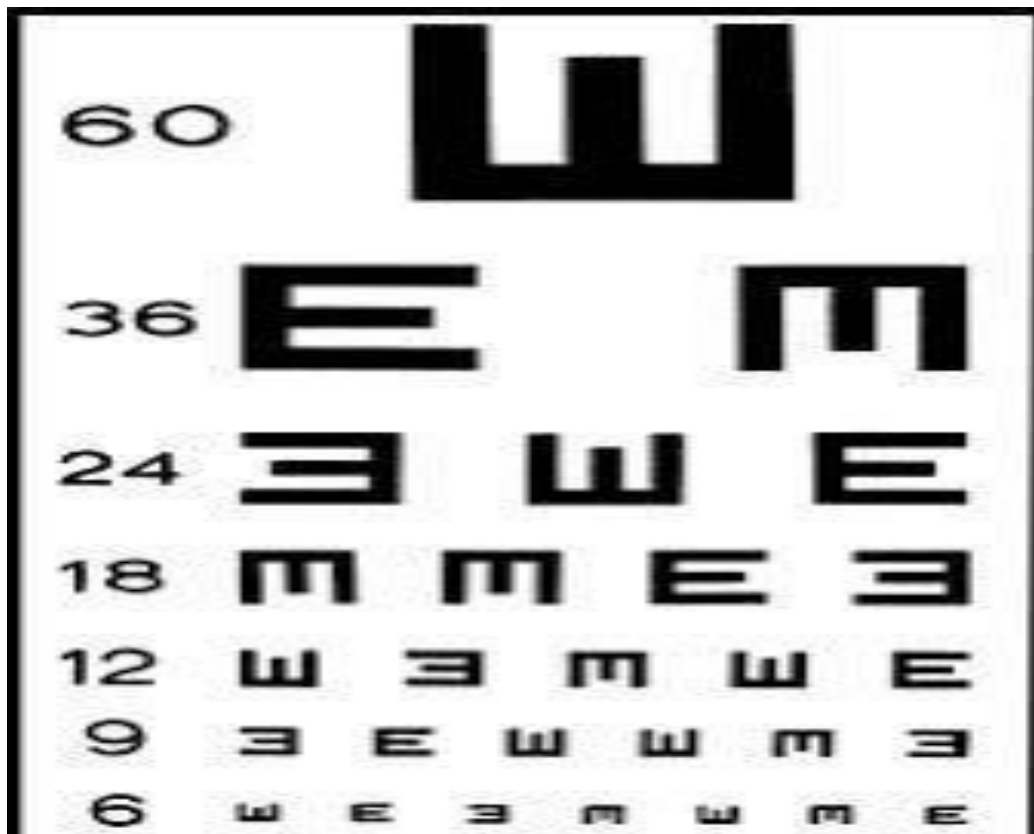
**Measurements:**

- 6/6: It means you have normal vision. You can see details from 6 meters away as well as an average person can.
- 6/5: It means you have better than normal vision. You can see details smaller than 6 meters, meaning you see better than the average person.
- 6/1: It means you have very poor vision. You can only see what a normal person can see from 1 meter away, which means you need to get very close to see details.

Conclusion:

- Best: 6/5 (better than normal vision)
- Then: 6/6 (normal vision)
- Less: 6/1 (very poor vision)

If you have any additional questions, please feel free to ask



Department of Optics Techniques

Lecture 4

Trial case

M.S.C. Hayder Sobhi AL-DOURY

Trial case

In practical applications, the combination of all types of trial case lenses is called a trial lens set. A trial lens set is a type of ophthalmology measuring instrument used in ophthalmology departments in hospitals and opticians to detect the refractive state and strabismus, or amblyopia and other visual.



Functions of the human eye

It can be helpful to think of very basic lens forms in terms of prisms. Recall, as light passes through a prism it is refracted toward the prism base. Minus lenses therefore resemble two prisms apex to apex spreading light rays outward as they pass through the lens, while plus lenses resemble two prisms base to base converging light rays as they pass through the lens.

Trial case lenses mainly consist of positive and negative spherical power trial case lenses, positive and negative cylinder power trial case lens and prismatic power trial case lenses, as well as supplemental trial case lenses etc. Trial case lenses can be divided into categories as below:

1. Spherical – power trial case lenses

A spherical- power trial case lens consists of a positive and a negative spherical- power trial case lens. Positive spherical- power trial case lenses are used for the detection of hyperopia and presbyopia in the human eye; negative spherical – power trial case lenses are used for the detection of myopia.



2. Cylinder – power trial case lenses

A cylinder- power trial case lens consists of a positive and a negative cylinder- power trial case lens. Positive cylinder- power trial case lenses are used for the detection of

hyperopia, presbyopia and astigmatism in the human eye; negative cylinder – power trial case lenses are used for the detection of myopia and astigmatism in humans.



3. Prismatic – power trial case lenses

Used for the detection of the strabismus and heterophoria in the human eye.



Supplemental trial case lenses

It normally consist of cross-cylinder lenses, Maddox rod lenses, pinhole lenses, opaque lenses, stenopeic lenses, Plano lenses, frosted lenses, crosshair lenses, filters and polarisers, etc.

- **cross-cylinder lenses**

Cross-cylinder lens is a type of special cylinder lens, which has two mutual perpendicular orientations, indicated by the same two numerical values with opposing plus and minus symbols, marking the positive and negative cylindrical vertex powers respectively. Cross- cylinder lenses are used for the detection of the axial position and the cylindrical power of cylindrical lenses.



- **Maddox rod lenses**

A Maddox rod lens consists of a row of smooth cylinders with the same diameter, and has the function of light transmission.



- **Opaque lenses**

Opaque lenses are also called opaque discs. These lenses are completely opaque and are used to cover whichever eye is not undergoing examination.



- **Pinhole lenses**

A pinhole lens is an opaque lens with a clear aperture in the center. It is mainly used to distinguish whether hyperphysical eyes are caused by refractive errors or pathological change of the eyes. The clear aperture should be round, smooth, and other parts of the pinhole lens should not allow light to pass through.



- **Stenopeic slit lenses**

A stenopeic slit lens is an opaque lens with a narrow slit which allows light

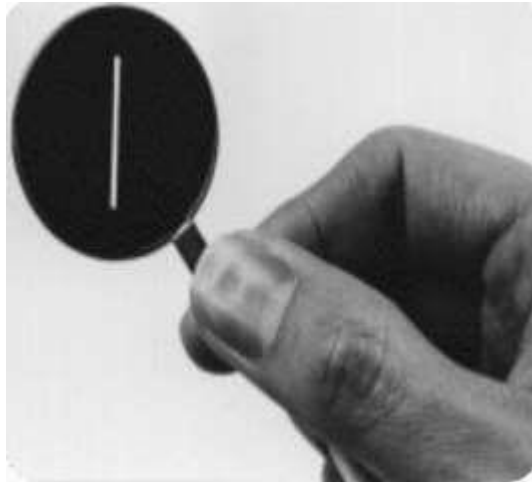

transmission. It used for astigmatism inspection.

□ Frosted lenses

Frosted lenses are semi-transparent and are used by young children or outdoors to replace opaque.



□ Plano lenses

Plano lenses are transparent and are used to test conditions such as simulated blindness.



□ Filters

Filters are Plano lenses. They normally include red and green lenses, used for chromatometry. The combination of red and green lenses can be used for binocular stereo vision testing, or for visual function testing of people with refractive media opacity. Red filters can also be used for amblyopia treatment and for chromatometry. There is also a tawny filter which can be used in lenses for examining the vision of people with photophobia.





department of Optics Techniques

Lecture fifth and sixth

Retinoscopy

M.S.C. Hayder Sobhi AL-DOURY

Retinoscopy

Retinoscopy is an objective refraction device that can estimate a person's refractive error without them needing to say anything to you. Retinoscopy should be done for every person that you examine as it gives you information that you cannot get any other way. It is also extremely useful for people who cannot communicate with you – such as young children or people with mental. Doing retinoscopy for every person that you examine will make your refraction faster, more efficient and more accurate. Light is directed into the patient's eye to illuminate the retina. An image of the illuminated retina is formed at the patient's far point (the reflex stage).

Parts of Retinoscope □ Power switch

- Turns the retinoscope on and off
- Controls the brightness of the light.

□ Small globe (light bulb)

- Provides the light

□ Electric supply

- Batteries (disposable or rechargeable) in the retinoscope handle, or - A power cord to connect the retinoscope to the main electricity.

• Mirror

- Reflects light from the globe into the person's eye

• Sight hole (viewing hole)

- Allows the red reflex to be seen.

□ Slide knob or sleeve

- Rotates the axis of the retinoscopes light, and
- Changes the light beam from divergent to convergent light.

If a retinoscope is not working, it is usually because:

- It needs new batteries, or its rechargeable batteries need to be recharged.
- The light globe needs changing – each globe usually lasts for several years.

The uses of retinoscopy Retinoscopy

allows you to:

1. Estimate a person's refractive error before you begin your subjective refraction, it provides a starting point for your refraction.
2. Estimate the refractive errors of people who have problems communicating with you, such as:

- ❖ babies or young children
- ❖ people with a physical or mental disability
- ❖ people who speak a language that you do not understand ❖ Deaf or mute people.

Detect some eye diseases (like cataract or corneal opacities) that can affect a person's vision and your refraction examination.

Red reflex and type of movement

When we shine the light of a retinoscope into a person's eye, we can look at the light reflected back from the retina. This reflected light is called the retinoscopic reflex (or simply, the "red reflex"). The red reflex looks like a red light inside the person's pupil.

Depending on the person's refractive error, when we move the retinoscope, the red reflex will move in a particular way inside the pupil which looks like a narrow band of red light that covers part of the pupil. Trial lenses can be used to measure the amount of movement that a red reflex has so that the refractive error can be estimated accurately. This

movement is called "sweeping". Sweeping is done to "scope" (search) for refractive error in a person's eye.

Sweeping should be a smooth, repetitive movement. It should be done several times back-and-forth, up-and-down and in oblique directions. Sweeping in different directions lets us look for astigmatism and measure the refractive error of the eye in different power meridians of the eye.

Light from streak on trial lens rim

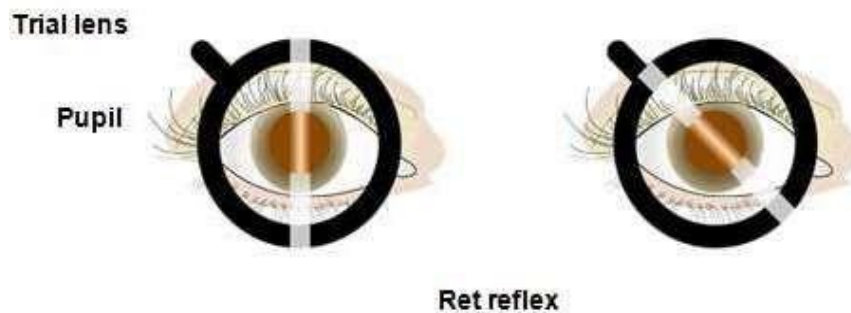

Figure (1): View through the sight hole of a streak retinoscop

When you move the retinoscope, the red reflex also moves. The movements of the red reflex may be "with", "against" or "neutral".

With movement

When the red reflex moves in the same direction as the sweeping motion of the retinoscope streak, it is called "with".



Figure 5: A red reflex showing "with" movement.

Figure (2): A red reflex showing "With" movement.

Against movement

When the red reflex moves in the opposite direction to the sweeping motion of the retinoscope streak, it is called "against" movement.

"Against" movement



Figure (3): A red reflex showing "Aganist" movement.

ELEMENTARY OPTICS

- *Light*

PHYSICAL OPTICS

- *Wave optics*
- *Quantum optics*

GEOMETRICAL OPTICS

- *Reflection of light*
- *Refraction of light*

PHYSIOLOGICAL OPTICS (OPTICS OF THE EYE)

LIGHT

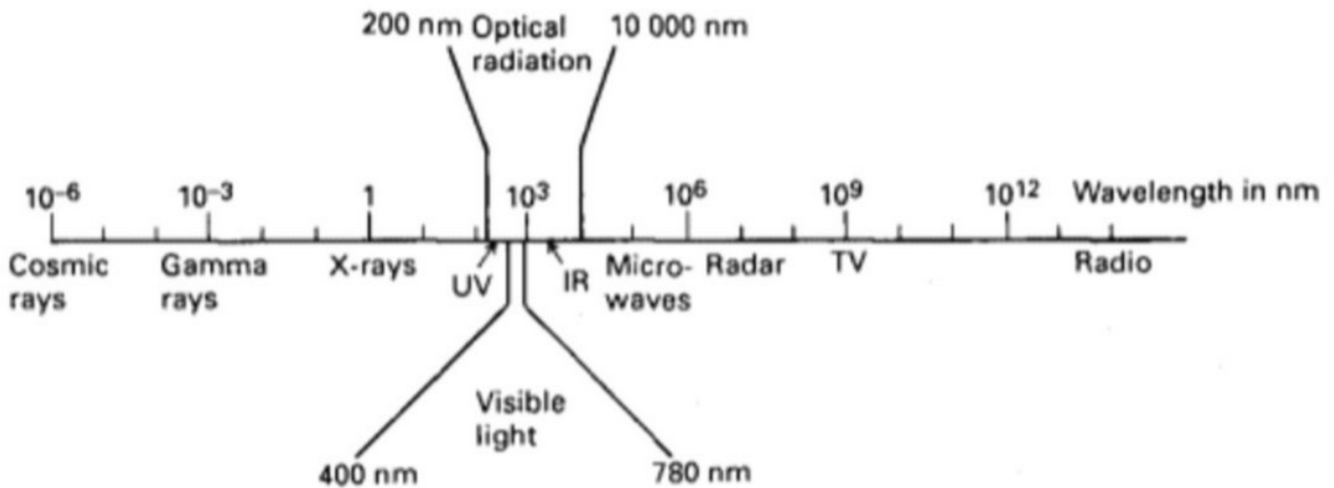

- Form of energy whose interaction with retina gives the sensation of sight.
- It is visible portion of the electromagnetic radiation spectrum.
- It lies between ultraviolet and infrared portions 400 nm - 700 nm.
- The white light = (violet, indigo, blue, green, yellow, orange and red) = VIBGYOR

- Optical radiation (200 nm to 10000 nm) is subdivided into 7 wavebands due to the similar biological reactions:
 - 1) ultraviolet C (UV-C), 200–280 nm
 - 2) ultraviolet B (UV-B), 280–315 nm
 - 3) ultraviolet A (UV-A), 315–400 nm
 - 4) visible radiation, 400–780 nm
 - 5) infrared A (IRA), 780–1400 nm
 - 6) infrared B (IRB), 1400–3000 nm
 - 7) infrared C (IRC), 3000–10000 nm.
- **Rule:** the shorter the wavelength, the greater the energy
- The cornea and sclera absorb (UV-C and UV-B) and (IR-B and IR-C).
- The crystalline lens absorbs UV-A
- visible light and near infrared (400–1400 nm) pass through the ocular media to fall on the retina ⇒ the visible wavelengths stimulate the retinal photoreceptors while the near infrared cause thermal retinal damage (eclipse burns).

Ultraviolet Light

- ★ Newly aphakic patients frequently remark that "everything looks bluer than before the operation" because retinal photoreceptors are also sensitive to wavelengths between 350 nm and 400 nm which are normally absorbed by the lens
- ★ Wavebands between 350 nm in the UV and 441 nm in the visible spectrum are potentially the **most dangerous** for causing retinal damage under normal environmental conditions.
- ★ Intraocular implant lenses are therefore being produced which incorporate a UVA absorbing substance.
- ★ **Prolonged** exposure to bright (high intensity) illumination employed in ophthalmic instruments is potentially damaging to the retina → Some instruments have **yellow filters** built into them to reduce exposure to the most damaging wavelengths.

Properties of light

- It does not require medium for its propagation.
- Speed of light in vacuum (3×10^8 m/s) > speed in medium.
- Transverse in nature, so can be polarized.
- Monochromatic light = light of a single wavelength. White light is heterochromatic.
- Not deflected by electric and magnetic field.

Nature of light

Wave Optics

- *Interference.*
- *Diffraction.*
- *Polarization.*

Quantum Optics

- *Transmission and absorption of light.*
- *Scattering of light.*
- *Photoelectric effect.*
- *LASER.*
- *Fluorescence.*

Wave Theory of Light

- **Light really travels as waves** although its path is often represented diagrammatically as a 'ray' travelling from left to right (\rightarrow).

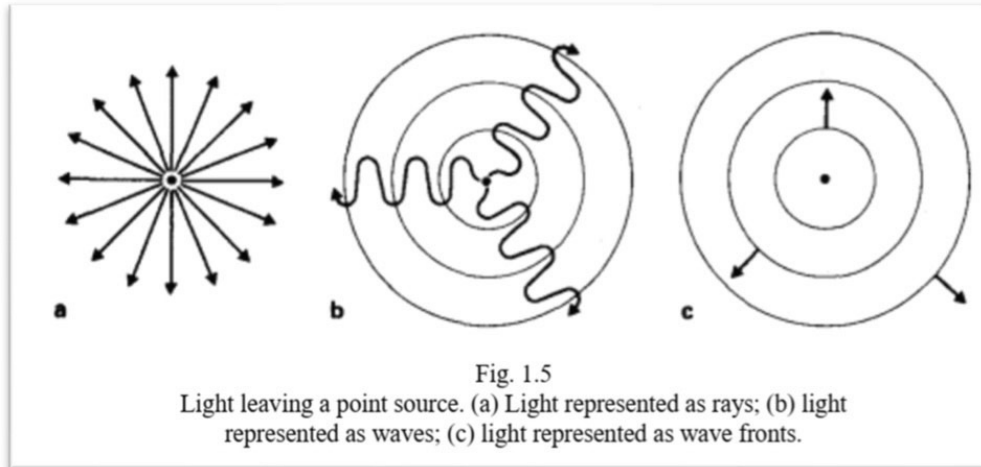

- Wave motion consists of a disturbance (energy) passing through a medium. The medium itself **does not** move, but its constituent particles vibrate at **right angles** to the direction of travel of the wave.
- The *wavelength* (λ) is defined as the distance between two **symmetrical** parts of the wave motion.

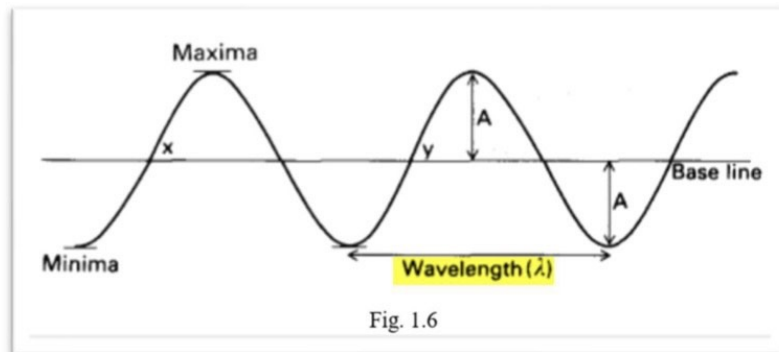

- One complete oscillation is called a *cycle*, e.g. $x y$, Fig. 1.6, and occupies one wavelength. **Any portion of the cycle is called a phase.**
- The *amplitude* (A) is the **maximum** displacement from the base line.

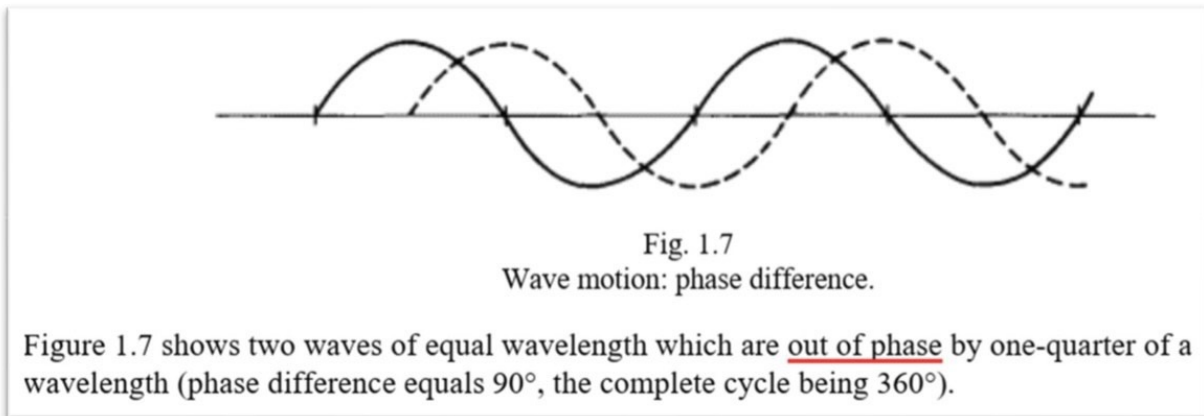

- Light waves that are **out of phase** are called ***incoherent***, while light composed of waves exactly **in phase** is termed ***coherent***.

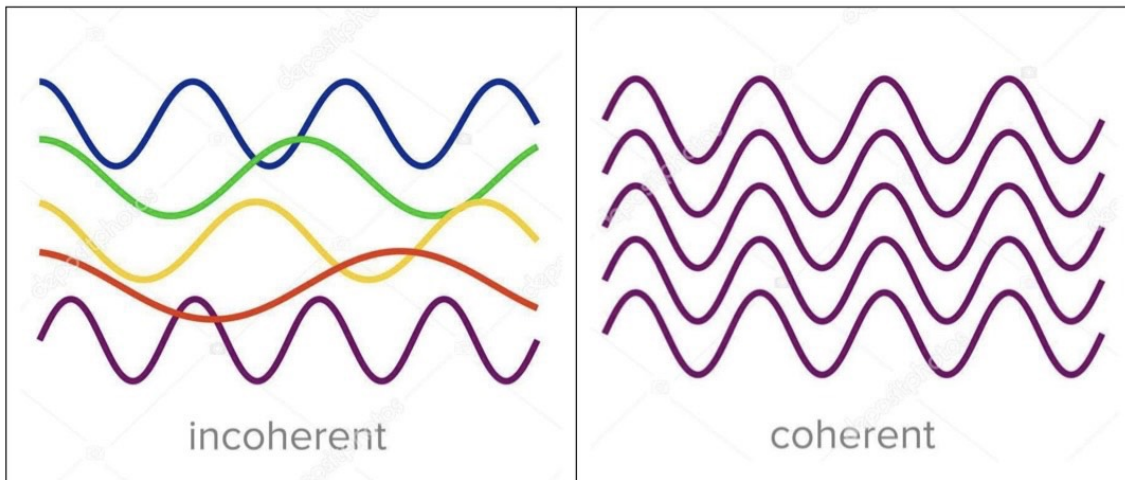

1. Interference

- Ψ If the two waves are in phase, the resultant wave will be a summation of the two, and this is called ***constructive interference*** (Fig. 1.8a).
- Ψ If the two waves of **equal amplitude** are **out of phase by half a cycle** (Fig. 1.8b), they will cancel each other out: ***destructive interference***.
- Ψ Destructive interference occurs within the **stroma** of the cornea.

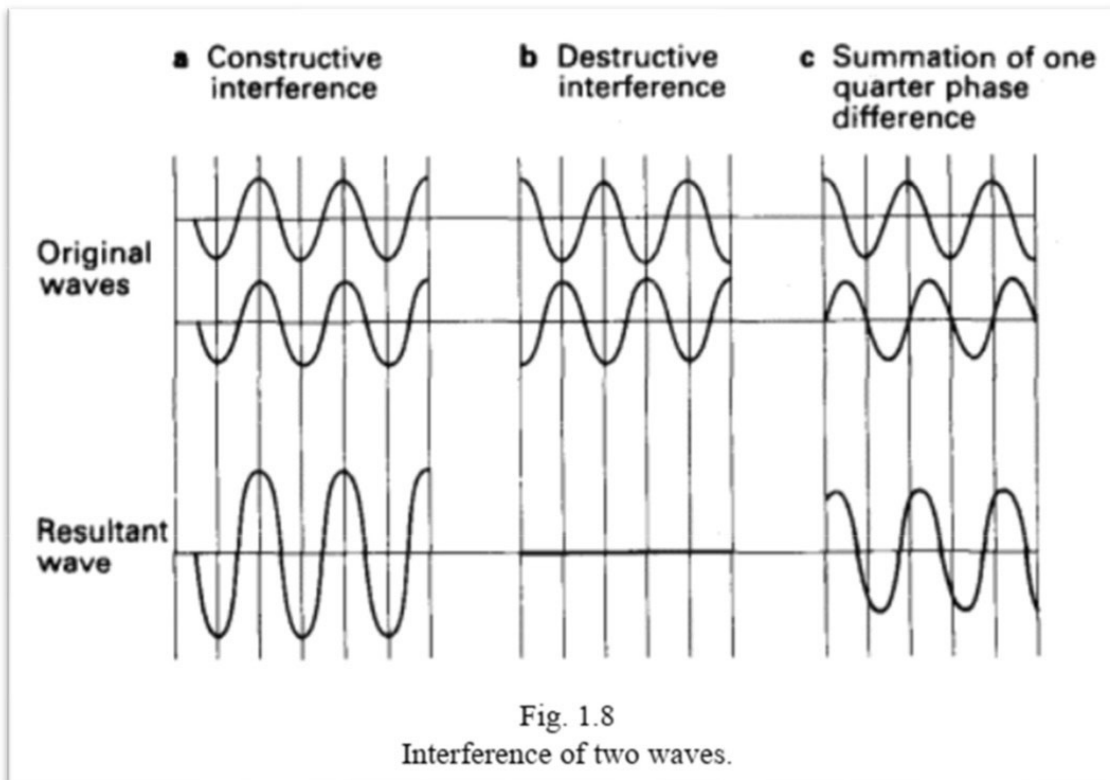

2. Diffraction

- When a wave front encounters a narrow opening, it is as if the edge of the obstruction acts as a new centre from which secondary wave fronts are produced which are **out of phase** with the primary waves.

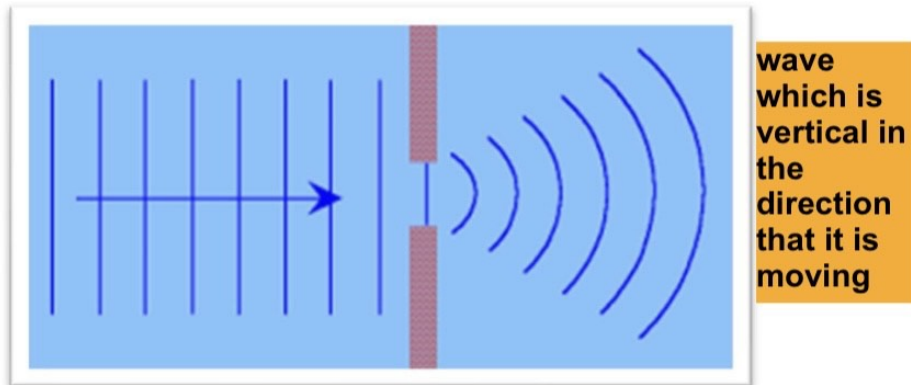

- When light passes through a **circular aperture**, a circular diffraction pattern is produced. This consists of a bright central disc surrounded by alternate dark and light rings. The central bright zone is known as the Airy disc.

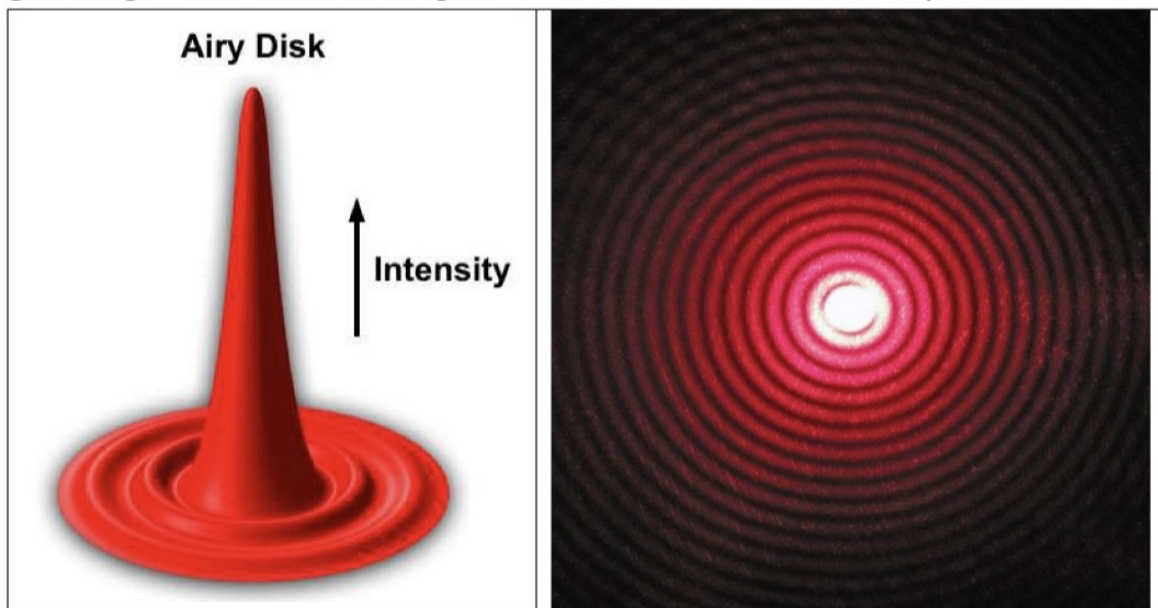

- Diffraction effects are **most marked** with **small** apertures.

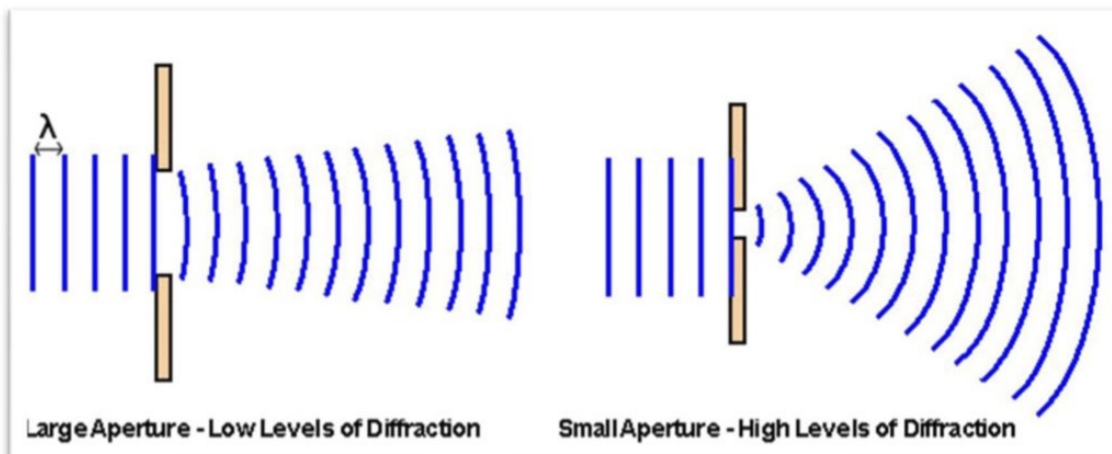

- In the case of the eye, diffraction is the main source of image imperfection when the pupil is **small**.
- The principle of diffraction is used in the design of some multifocal intraocular lenses.

Resolving Power (Limit of Resolution)



- The *limit of resolution* is reached when two Airy discs are separated so that the centre of one falls on the **first** dark ring of the other.

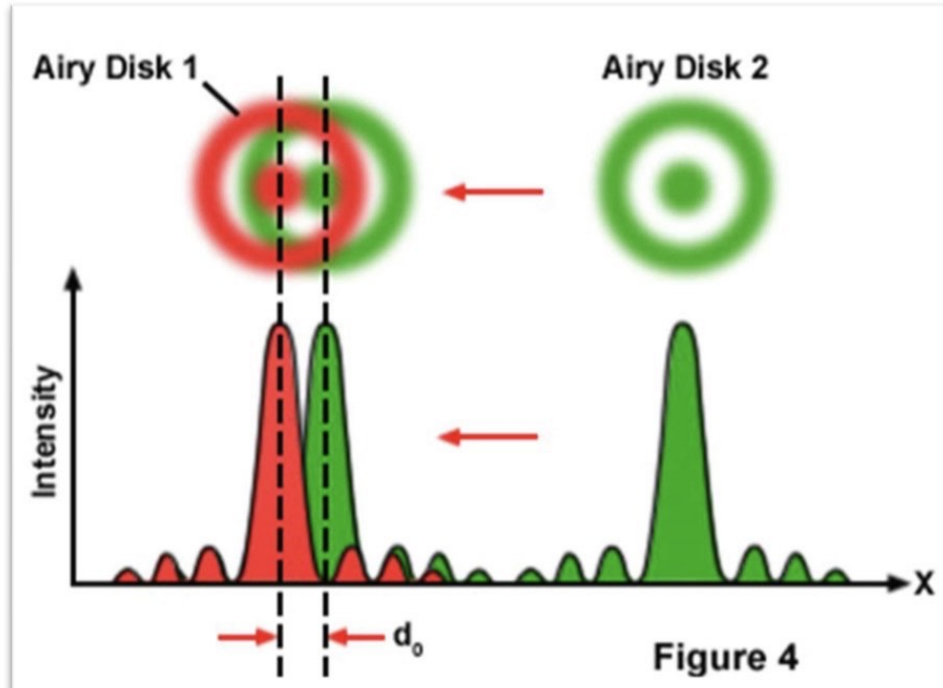

3. Polarization

The ordinary light's waves vibrate in more than one plane, it is unpolarized light.

Polarized light may be produced from ordinary light by:

1. Absorptive: unwanted polarization state absorbed by device (e.g. calcite crystals) which transmits light rays vibrating in one particular plane only. A polarising medium reduces radiant intensity but does not affect spectral composition.

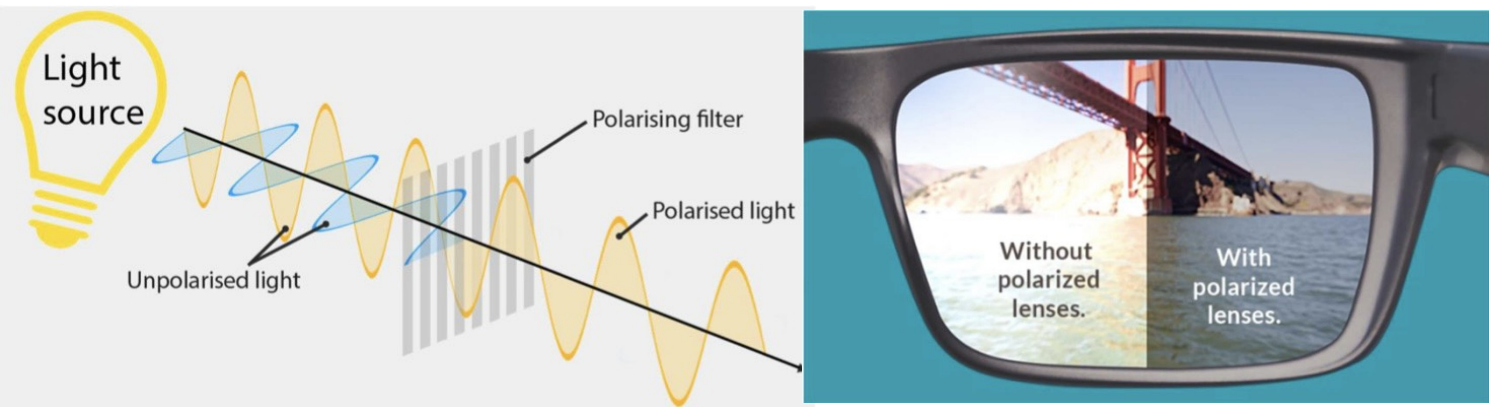

2. Beam - splitting: unpolarized beam is splitting into 2 beams with opposite polarization states (Birefringent polarizers). A birefringent substance (e.g. crystals of quartz) has two refractive indices. it transmits light waves lying parallel to its structure and selectively slows and redirects light waves vibrating in a plane perpendicular to its structure (i.e. it splits incident unpolarised light into two polarised beams travelling in two directions..

Wollaston prism:

It consists of two rectangular quartz prisms cemented together with the optical 'grain' of the crystal at right angles → it is possible to separate the two emergent beams by a fixed angle,

while the dispersion produced by the first prism is neutralised by that of the second prism allowing sharp images to be formed

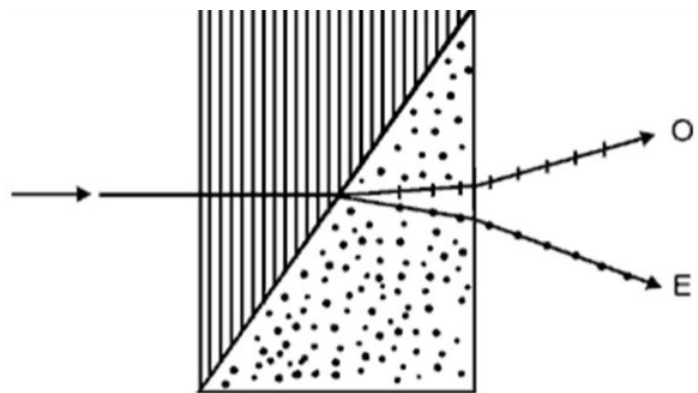

Quantum theory of light

1. Fluorescence

★ It is the property of a molecule to spontaneously emit light of a **longer** wavelength when stimulated by light of a shorter wavelength.

★ Examples of fluorescent substances:

1. **Fluorescein sodium (orange) dye**: when excited by blue light (465–490 nm) emits yellow–green light (520–530 nm).
2. **Indocyanine green (ICG) dye**: absorbs 805^{IR}nm and emits 835^{IR}nm.

Fluorescein *angiography*

It allows studying of retinal and choroidal circulation by photographing the passage of fluorescein through the vasculature after it has been administered systemically.

- White light passes through a **blue 'excitation'** filter to illuminate the fundus with blue light.
- - Most of the light is absorbed
 - some is reflected unchanged
 - some is changed to yellow–greena **yellow–green 'barrier'** filter blocks the reflected unchanged blue light and exposes the camera film only to yellow–green light → delineating vascular structures and leakage of dye

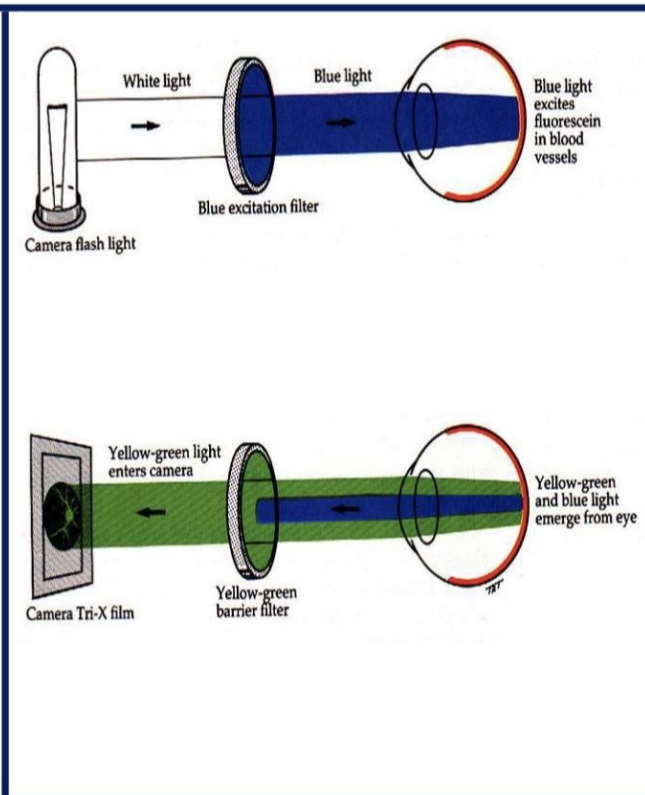

2. Scattering

When light travels in a medium in many small particles a light that hits particles is reflected off in a new direction. This phenomenon accounts for reflection and transmission (refraction) in a medium.

Tyndall effect: effect of the light beam becoming visible. Shining a flashlight beam in a glass of water after adding a few drops of milk is an excellent demonstration of the Tyndall effect. The milk proteins will stay suspended in the water (a colloid suspension), making the beam visible. Similarly, if we can see the beam of light in the aqueous humor during slitlamp examination, this is an indication of inflammation; in other words, an indication resulting from the presence of suspended protein in the aqueous.

Non ocular scattering

- 1. Blue appearance of the sky during daytime and its reddish appearance during sunrise or sunset.**
- 2. white appearance of clouds.**
- 3. formation of a rainbow..**

Ocular scattering

- 1. appearance of the cornea and lens under slitlamp examination.**
- 2. Scleral color**
- 3. Iris color.**
- 4. corneal edema and scar.**
- 5. cataract**

Mirrors

Mirrors are reflective surfaces used to reflect light and form images. Mirrors can be made of a variety of materials, but the most common is glass coated with a thin layer of metal, such as silver or aluminum.

Types of mirrors

Plane mirrors are a type of mirror with a smooth, flat surface, and are the most common and widely used.

Features:

- **Smooth surface:** The surface is free of defects, allowing light to be reflected evenly.
- **Resulting images:** Produces real images of the same size and orientation, but flipped vertically.
- **Angle:** The angle of incidence on the mirror is equal to the angle of reflection.
- **Easy to manufacture:** They are produced at a low cost compared to other types of mirrors.
- Suitable for everyday applications

Uses :

1. **Decoration:** Used in homes and offices to decorate walls and create a sense of spaciousness.
2. **Cosmetics:** Used in cosmetics and personal mirrors.
3. **Education:** Used in scientific experiments to illustrate the principles of reflection.

2- Concave mirrors

Concave mirrors are a type of mirror that has its reflecting surface concave inward, meaning that the reflecting part is directed toward the concave side. These mirrors have many properties and applications:

Features:

1. Image Formation: Concave mirrors can form real or virtual images, depending on the position of the object relative to the mirror.
2. Amplification And zoom in Image
3. Focusing light: Concave mirrors focus light rays to a specific point, making them useful in applications such as lamps or telescopes.

3- Convex mirrors

Definition of convex mirrors:

Convex mirrors are a type of mirror that has a convex outer surface, which causes it to reflect light in a certain way. These mirrors are typically used in applications that require a wide view or image magnification.

Features:

1. Image composition:

Convex mirrors produce virtual images.

- Images are always thumbnails and straight.

2. Viewing angle:

- Provides a wide field of view, making it ideal for use on car sidelights or in home mirrors.

Uses:

- Used in cars to provide better vision for the driver.
- Used in stores to monitor theft.
- Used in scientific applications such as microscopes.

Lenses

A lens is a transparent object that can be made of glass or plastic, and is used to modify the path of light. Lenses focus or disperse light rays, resulting in the formation of an image of objects.

Types of lenses

1-concave lenses

A concave lens is a type of lens that is thinner in the middle and thicker at the edges. These lenses are used to disperse or spread light rays, making them useful in a variety of applications.

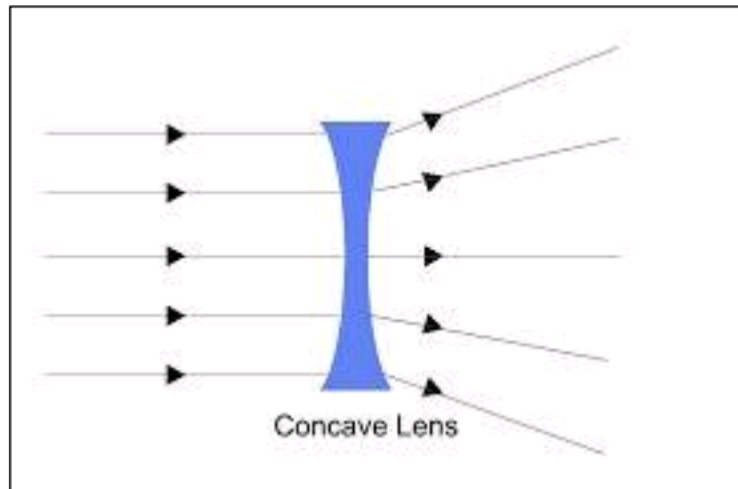

- General properties of concave lens

- Lens shape: It is concave on both sides, which allows light to be dispersed.
- Focus: Parallel light rays passing through a concave lens appear to come from a virtual point known as the focus, which is on the same side of the lens as the light entering.

Focal length: the distance between the lens and the focus. And it is negative.

- **uses of concave lens**

- In glasses: used to correct farsightedness (hyperopia) by scattering light to reach the retina properly.
- In cameras: Used in some types of cameras to correct optical distortions.
- In microscopes: used to magnify images in a certain way.

- **How to work concave lens:**

When light rays pass through a concave lens, the rays are refracted as they enter and exit, causing them to diverge. As a result, the rays appear to come from a virtual point behind the lens.

- **Other applications for concave lens.**

- Mirrors: Some types of mirrors are used for optical purposes.
- Optical devices: used in endoscopes and devices that require light dispersion.

Concave lenses play an important role in improving vision and facilitating many scientific and technical applications.

2-convex lens

It is a type of lens that is thicker in the middle and thinner at the edges. These lenses are used in many optical applications because of their ability to focus light rays.

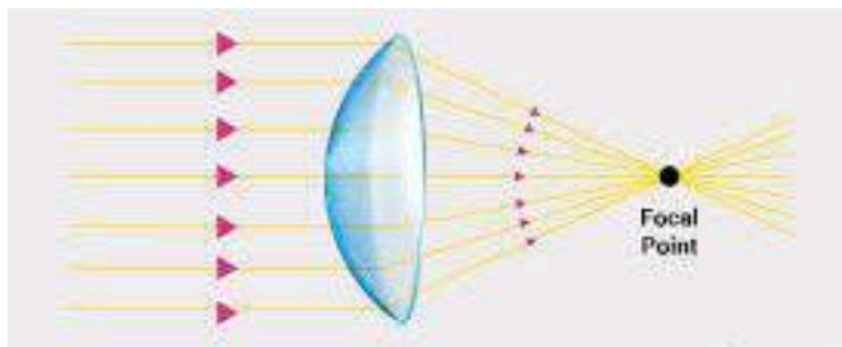

- **General properties of convex lens:**

Lens shape: A convex lens is concave on both sides, allowing light to be focused.

- Focus: Parallel light rays passing through a convex lens are focused at a point known as the focus. This point is located on the other side of the lens.

Focal length: The distance between the lens and the focus is known as the focal length, and it can be positive.

A Uses of convex lens:

- In glasses: used to correct myopia (myopia) by focusing the image on the retina.

- In cameras: used to improve image quality by focusing light.

- In microscopes: used to magnify fine images of small objects.

- **How to work convex lens:**

When light rays pass through a convex lens, they are refracted as they enter and exit the lens, causing them to focus at the focal point.

- **Other applications for convex lens:**

- Binoculars: Binoculars are used to see distant objects clearly.

- Projectors: Used in projectors to improve image display.

The convex lens is an essential tool in many optical applications, enhancing our ability to see the world around us clearly.

calculate

1- General law of mirrors and lenses

$$\frac{1}{f} = \frac{1}{u} + \frac{1}{v}$$

Magnification power equals

$$M = \frac{\text{بعد الجسم}}{\text{بعد الصورة}} = \frac{v}{u}$$

Definitions

1. Focus

The focus is the point where light rays converge after passing through a lens. In convex lenses, the focus is the point where parallel rays are focused, while in concave lenses, the rays appear to come from a virtual point also known as the focus.

2. Focal length

Focal length is the distance between the lens (or mirror) and the focus. It is usually expressed in units of length (such as millimeters or centimeters).

- In convex lenses, the focal length is positive, which means the focus is on the other side of the lens.

- In concave lenses, the focal length is negative, which means that the focus is on the same side of the lens that the light enters from.

3. Visual center

The optical center is the point in the middle of the lens where the principal axis of the lens intersects. Light rays passing through the optical center are unaffected, that is, they continue on their path without deviation. The optical center is an important reference point for determining lens properties, such as focal length.

Object distance (u)	Ray diagram	Type of image	Image distance (v)	Uses
$u = \infty$		<ul style="list-style-type: none"> - inverted - real - diminished 	$v = f$ - opposite side of the lens	- object lens of a telescope
$u > 2f$		<ul style="list-style-type: none"> - inverted - real - diminished 	$f < v < 2f$ - opposite side of the lens	- camera - eye
$u = 2f$		<ul style="list-style-type: none"> - inverted - real - same size 	$v = 2f$ - opposite side of the lens	- photocopier making same-sized copy
$f < u < 2f$		<ul style="list-style-type: none"> - inverted - real - magnified 	$v > 2f$ - opposite side of the lens	- projector - photograph enlarger
$u = f$		<ul style="list-style-type: none"> - upright - virtual - magnified 	- image at infinity - same side of the lens	- to produce a parallel beam of light, e.g. a spotlight
$u < f$		<ul style="list-style-type: none"> - upright - virtual - magnified 	- image is behind the object - same side of the lens	- magnifying glass

Visual Acuity

Visual acuity refers to the ability to see details clearly. It is usually measured using a visual acuity meter, with a person having 20/20 visual acuity being considered able to see details that are considered normal at 20 feet.

There are several factors that affect visual acuity, including:

1. Eye health : such as the presence of diseases such as retinopathy.
2. Environmental pollutants such as dust, toxic gases, etc.
3. Lighting : Good lighting helps improve vision.
4. Focus : The ability to focus on objects near or far.

Snellen chart (A Snellen Chart is a tool used to test visual acuity. The chart usually consists of a set of letters or symbols that vary in size, and is used to determine how well a person can see detail.

Components of the diagram:

1. Letters or symbols: Contain English letters (such as "E") or other symbols.
2. Different sizes: Letters range from uppercase to lowercase.
3. Visual acuity scale: It is used to measure visual acuity using a system such as 6/60 or 20/20.

How to use it:

1. Distance: The person is asked to stand 6 meters (or 20 feet) away from the chart.
2. Reading: The person is asked to read the letters from top to bottom.
3. Determine acuity: The best row that can be read clearly is recorded. If the person can read a particular row, the visual acuity measurement is determined based on the size.

Interpretation of results:

- 6/60: This means that a person sees from 6 meters what a normal person can see from 60 meters (poor vision).
- 6/6: means normal vision.
- 6/5: means better than normal vision.

Visual acuity test chart using Snellen chart

1. Setup

- Make sure there is good lighting.
- Sit 20 feet (6 meters) away from the table.

2. Eye Cover

- Cover the right eye (use a cloth or hand).

3. Reading letters

- Start from the top line and read the letters.
- Scroll down to the smallest letters you can clearly see.

4. Recording Results

- Write the appropriate number (such as 20/20 or 20/40) based on the line you were able to read.

5. Repeat the process

- Repeat the steps with the left eye.

6. Consult a doctor

- If you have any problems or questions, consult your eye doctor.

comments

- Make sure you are not wearing contact lenses or glasses if you want to measure your visual acuity without them.

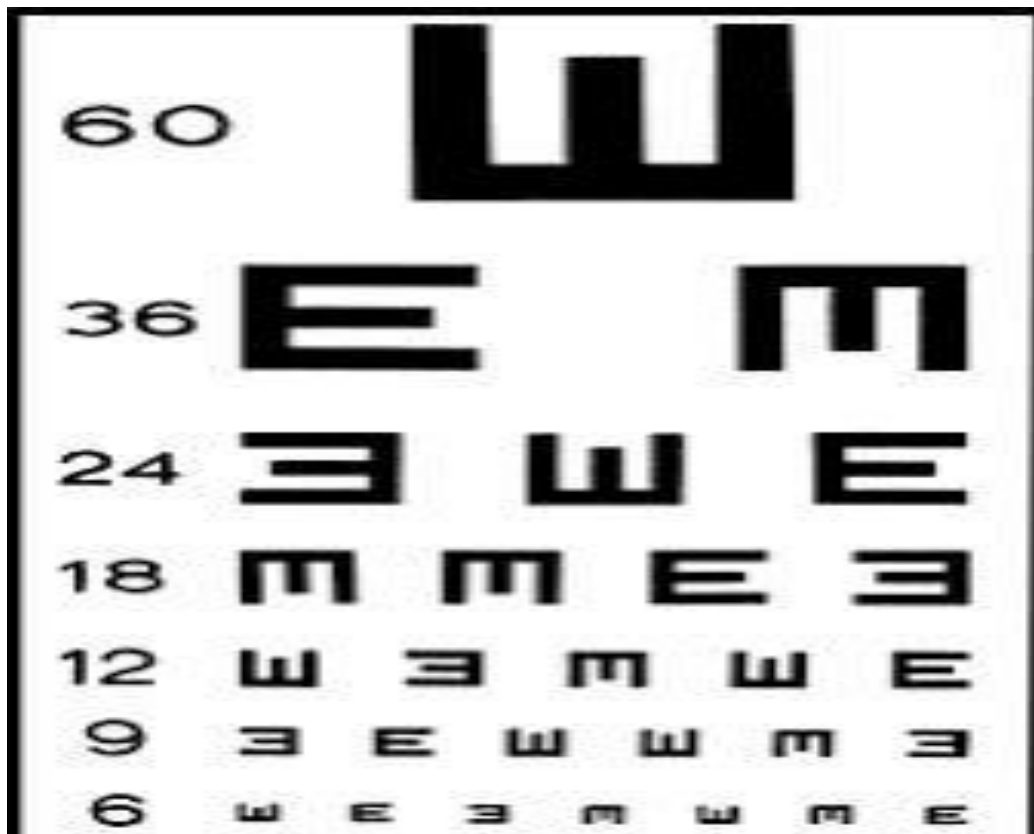

Measurements:

- 6/6: It means you have normal vision. You can see details from 6 meters away as well as an average person can.
- 6/5: It means you have better than normal vision. You can see details smaller than 6 meters, meaning you see better than the average person.
- 6/1: It means you have very poor vision. You can only see what a normal person can see from 1 meter away, which means you need to get very close to see details.

Conclusion:

- Best: 6/5 (better than normal vision)
- Then: 6/6 (normal vision)
- Less: 6/1 (very poor vision)

If you have any additional questions, please feel free to ask



REFRACTIVE ERROR

department of Optics Techniques

Lecture seventh

REFRACTIVE ERROR

M.S.C. Hayder Sobhi AL-DOURY

REFRACTIVE ERROR

A person who has a refractive error will need to wear spectacles (glasses) or contact lenses so that they can see clearly and comfortably.

This is because their eye is not the correct size and shape and light does not focus correctly on their retina.

If light from a distant or a near object does not focus properly on the retina, the person will have a problem seeing because they have a *refractive error*

There are four main types of refractive error: *myopia*, *hyperopia*, *astigmatism* and *presbyopia*.

The amount of refractive error that an eye has depends on:

the steepness/flatness of the cornea

the thickness/thinness of the crystalline lens

the length of the eyeball

A person may have a combination of any of these three things which make the eye the wrong size or shape, and will stop light from focusing perfectly on the retina (Figure 1).

When an eye has the correct size and shape to focus light on the retina, we say that the eye is *emmetropic*

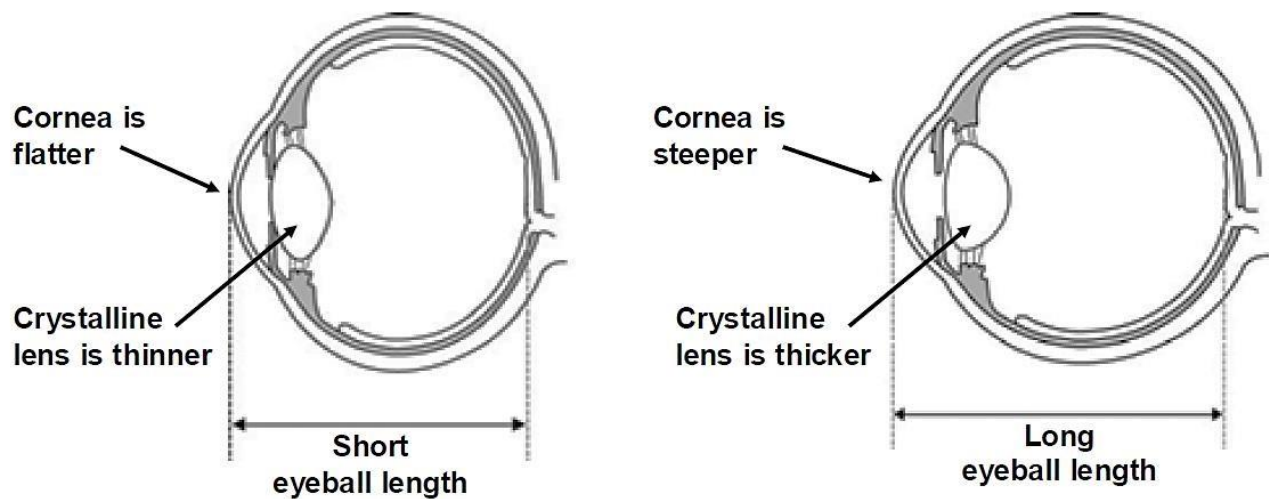

Figure 1: Possible differences in eyeball length, shape of the cornea, and shape of the lens.

THE NORMAL EYE

Light Entering the Eye

- Light rays entering the eye pass through the tear film, cornea, anterior chamber, pupil, crystalline lens and vitreous, before they reach the retina.
- Light rays are converged (focused) by the cornea and the crystalline lens.
- If the light rays focus correctly on the retina, a clear image will be formed.
- Light is changed at the retina into electrical signals (nerve messages).
- Information received by the retina is sent to the brain via the optic nerve.

Focusing Light in the Eye

In a normal eye, light that enters the eye is focused on the retina because:

- the cornea and the lens are the correct shape.
- the eyeball is the correct length.

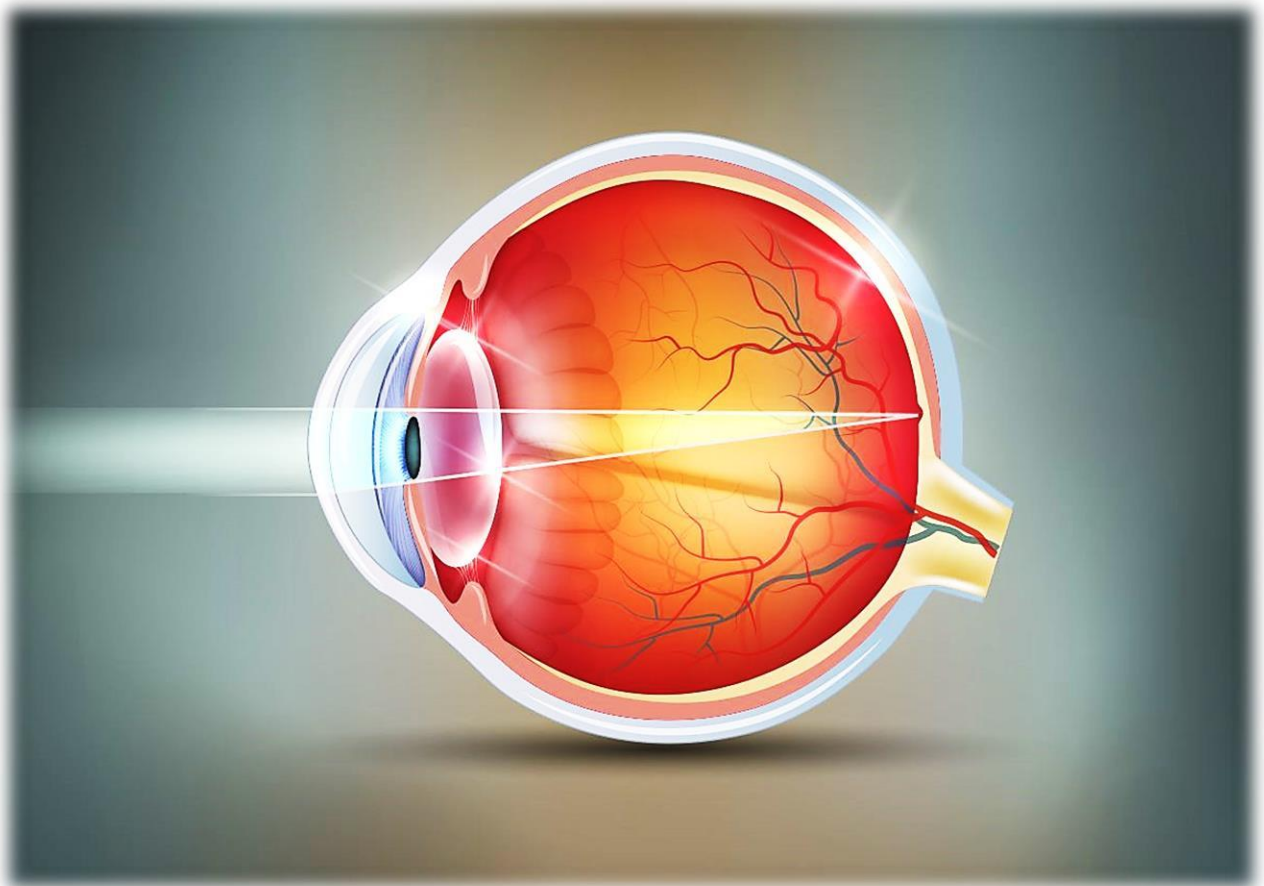

MYOPIA

(also known as shortsightedness or nearsightedness)

People with myopia (sometimes called “myopes”) can not see far away, but depending on the amount of myopia they have, their near vision might be good.

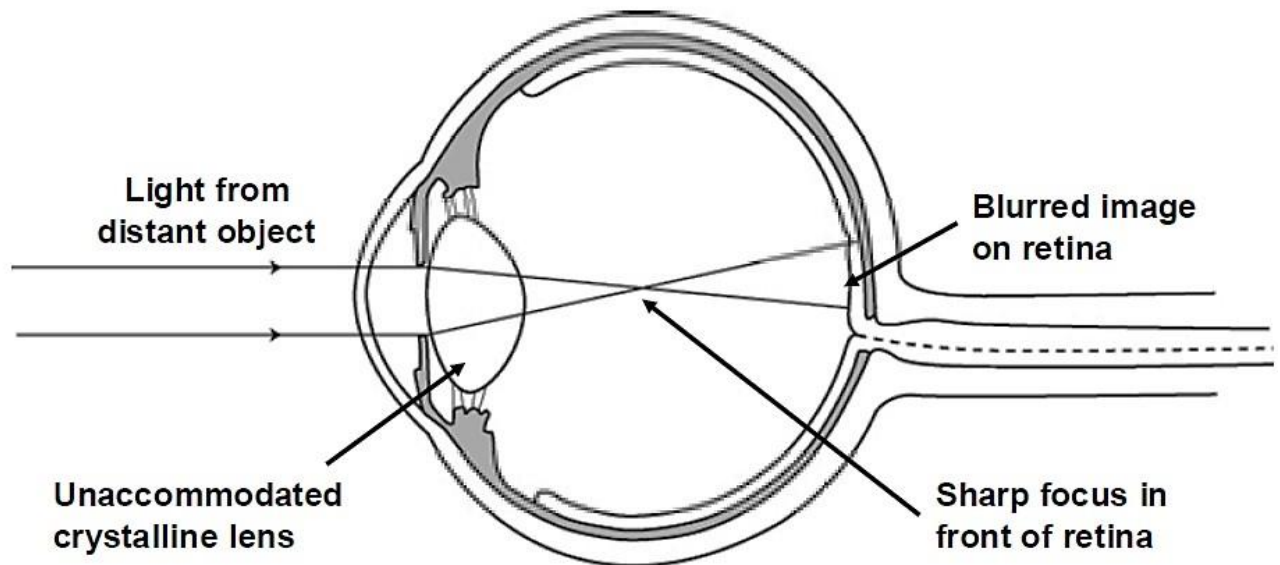

Figure 2: A myopic eye - light rays from a distant object focus in front of the retina

Causes of Myopia

† Based on Anatomical Features

1. Axial Myopia

- It is due to relatively long axial length.
- 1 mm axial length lengthening will cause -3.00 D of myopia.

2. Curvature Myopia

- It is due to the decreased radius of curvature of the refractive surfaces, i.e. cornea and lens.
- 1 mm steepening will cause -6.00 D of myopia.
- It is found in keratoconus, lenticonus and megalocornea

3. Index Myopia

- It is due to increase in refractive index of the lens nucleus which occurs in nuclear sclerosis.

4. Displacement of Refractive Element

- It is due to forward displacement of lens.

Symptoms of Myopia اعراض قصر البصر

- A person with myopia has blurry distance vision, also have blurry near vision (but their distance vision will always be worse).
- Eye strain or asthenopia
- Exophoria or Latent divergent squint
- Floaters and/or flashes of light in front of the eyes - Photophobia and impaired vision at night.

Signs of Myopia علامات قصر البصر

- Prominent eyes
- Large pupil and deep anterior chamber

Correction of myopia

- **Eyeglasses:** Prescription glasses with minus (concave) spherical lenses.

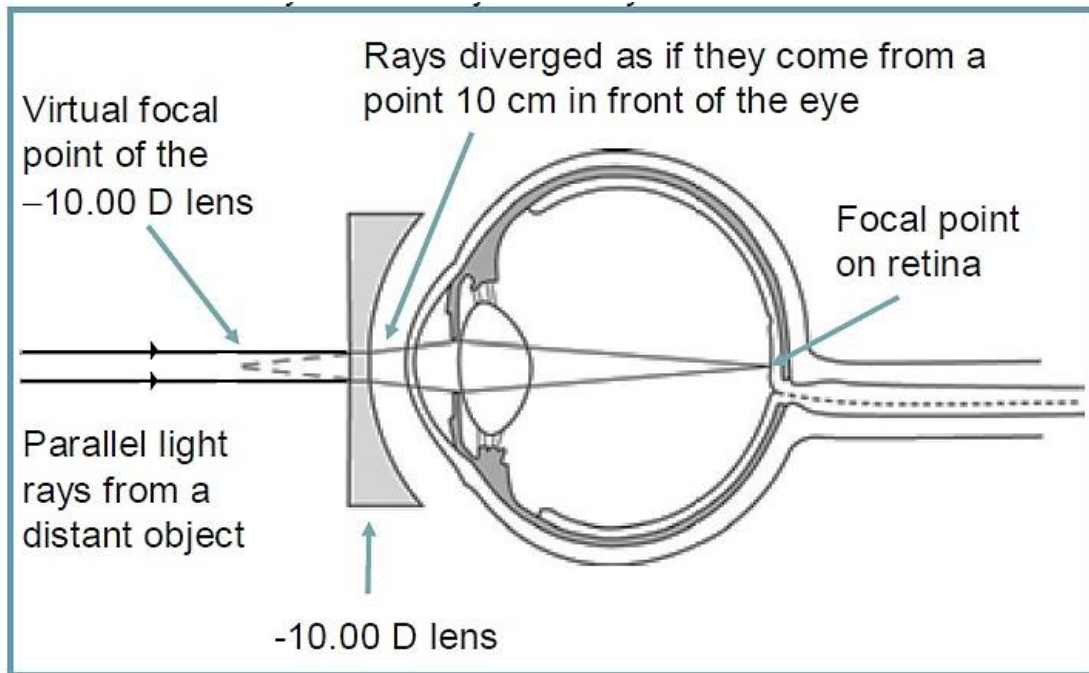

Figure 3: You can see that the -10.00 D lens diverges the light rays before they reach the eye – as if they were coming from a point 10 cm in front of the eye.

- **Contact Lenses:** Soft or rigid gas-permeable contact lenses can be used to correct myopia without the need for glasses.

Refractive Surgery:

- **LASIK (Laser-Assisted In Situ Keratomileusis):** This surgery reshapes the cornea using a laser to correct refractive errors, including myopia.
- **PRK (Photorefractive Keratectomy):** Similar to LASIK, but without creating a flap on the cornea. It is often recommended for individuals with thinner corneas.
- **SMILE (Small Incision Lenticule Extraction):** A minimally invasive form of refractive surgery that removes a small piece of tissue from the cornea to correct vision.

- **Orthokeratology (Ortho-K):** This involves wearing specially designed gas-permeable contact lenses overnight. They reshape the cornea temporarily, providing clear vision during the day.
- **Bifocal or Progressive Eyeglasses:** These lenses have different zones for near and distance vision correction. They can be used for individuals with myopia and presbyopia.



Myopia

Lecture eighth and ninth
M.S.C. Hayder Sobhi AL-DOURY

Ememetropia

when parallel rays of light coming from infinity are focused in sensitive layer of retina with accommodation being at rest

Ametropia

- •

Parallel ray of light coming from infinity (with accommodation at rest)are focused either in front or behind retina .

Type

- :
- -----Axial length and
- -----AC depth
- -----Corneal curvature
- •

Myopia

Dioptric condition □

in which Myopia or shortsightedness is a type □
of refractive error parallel rays of light coming
from infinity are focused in front of retina
with the accommodation is at rest .

□

Optic myopia

The optical system is too powerful for its axial length distant object on retina is made up of circle of diffusion formed by divergent beam since the parallel rays of light coming from the infinity are focused in front of the retina .

Type of classification

Clinical classification □

Age of onset □

Degree of myopia □

Clinical classification

- 1- Congenital myopia □
- 2- Simple or developmental myopia □
- 3- Pathological myopia □
- 4- Acquired myopia (secondary)which may be □
 - Post traumatic □
 - --Post keratitis □
 - Drug induced □
 - --Night myopia- □

Congenital myopia

--- Since birth □

----Mostly unilateral □

Diagnosed at 2-3 years----- □

Child may develop convergent squint in order to □
preferentially see clear at its far point (10 – 12 cm)

May Associated with cataract ,microphthalmos □
megalocornea ,congenital separation of retina.,

Simple myopia □

myopia

Developmental myopia – commonest variety □
(school going age 8-12 years)

Axial type (physiological variation in length of eye □
- ball ,powerful neurological growth during
childhood.

-Curvature type (un development of eye ball)- □

Pathological myopia

- degenerative or progressive myopia □
- rapidly progressive error which starts in childhood □
at 5-10 year of age .

It may be heredity or in some times choroid □
undergo due to stretching degeneration

((lengthening of posterior segment of eye globe □
commences only during the period of active growth
and ends with termination of active growth .))

Degree of myopia

: very low -----(up to 1.00 D
low – --- (1.00----3.00)D -
medium - 3.00 ---- 6.00)D- :
high - - (6.00 ---10.00)D - : □
very high 10.00 D -: above □



Hypermetropia

Lecture tenth and eleventh

M.S.C. Hayder Sobhi AL-DOURY

Signs and symptoms

In young patients, mild hypermetropia may not produce any symptoms. The signs and symptoms of far-sightedness include blurry vision, frontal or fronto temporal headaches, eye strain, tiredness of eyes etc. The common symptom is eye strain. Difficulty seeing with both eyes (binocular vision) may occur, as well as difficulty with depth perception. The asthenopic symptoms and near blur are usually seen after close work, especially in the evening or night. □

Complications

Far-sightedness can have rare complications such as strabismus and amblyopia. At a young age, severe far-sightedness can cause the child to have double vision as a result of "over-focusing". □

Hypermetropic patients with short axial length are at higher risk of developing primary angle closure glaucoma, so, routine gonioscopy and glaucoma evaluation is recommended for all hypermetropic adults. □

Causes

Simple hypermetropia, the most common form of hypermetropia, is caused by normal biological variations in the development of eyeball. Aetiologically, causes of hypermetropia can be classified as:

Causes

Axial: Axial hypermetropia occur when the □ axial length of eyeball is too short. About 1 mm decrease in axial length cause 3 diopters of hypermetropia. One condition that cause axial hypermetropia is nanophthalmos.

Curvatural: Curvature hypermetropia occur □ when curvature of lens or cornea is flatter than normal. About 1 mm increase in radius of curvature results in 6 diopters of hypermetropia. Cornea is flatter in micro cornea and cornea plana

Causes

Index: Age related changes in refractive index □
(cortical sclerosis) can cause hypermetropia.
Another cause of index hypermetropia is diabetes.
Occasionally, mild hypermetropic shift may be seen
in association with cortical or sub capsular cataract
also.

Positional: Positional hypermetropia occur due to □
posterior dislocation of Lens or IOL. It may occur
due to trauma.

Causes

Consecutive: Consecutive hypermetropia occur due to surgical over correction of myopia or surgical under correction in cataract surgery •

Functional: Functional hypermetropia results from paralysis of accommodation as seen in internal ophthalmoplegia, etc. •

Absence of lens: Congenital or acquired aphakia cause high degree hypermetropia. •

Diagnosis

A diagnosis of far-sightedness is made by utilizing either a retinoscope or an automated refractor-objective refraction; or trial lenses in a trial frame or a phoropter to obtain a subjective examination. Ancillary tests for abnormal structures and physiology can be made via a slit lamp test, which examines the cornea, conjunctiva, anterior chamber, and iris

Classification

Classification according to severity □

Clinical classification □

Clinical classification

Simple hyperopia: Occurs naturally due to biological diversity. •

Pathological hyperopia: Caused by disease, trauma, or abnormal development. •

Functional hyperopia: Caused by paralysis that interferes eye's ability to accommodate. •

Classification according to severity

Low: Refractive error less than or equal to $+2.00$ D up to $+2.00$ diopters (D).

Moderate: Refractive error greater than $+2.00$ D up to $+5.00$ D.

High: Refractive error greater than $+5.00$ D

Treatment

Corrective lenses □

Surgery □

-----Laser procedures □

-----IOL implantation □